



**Operating Instructions for Pellet Press
Type PP40**

Retsch[®]

Notes on these operating instructions	3
Warning instructions	3
Repairs	3
Safety	4
Safety instructions	4
Safety instructions – summarised, part 1	5
Confirmation	7
Technical data	8
Use according to the intended purpose	8
Pressing nominal volume	8
Maximum charged grain size	8
Driving power	8
Press force	8
Hydraulic pressure	8
Emissions	9
Systems of protection	9
Protective equipment	9
Mode of operation	9
Machine dimensions	9
Required floor space	9
Transport and installation	10
Packing	10
Transport	10
Temperature variations	11
Intermediate storage	11
Erection	11
Parameters for the place of installation	11
Ambient temperature: 5°C to 40°C	11
Atmospheric humidity	11
Installation height: max. 2000 m above sea level	11
Electrical connection	11
Important instructions for electrical connection	12
Serial interfaces	12
Operation	13
Connecting the power supply	13
Opening / closing / emergency unlocking	13
Before starting the PP40	14
Insertion of pellet press rings and aluminum cups of the PP40	15
Preparation of the pressing process	16
Pellet press ring filling level	16
Parameter Setting Example	16
Removal of the pellet	16
Manual cleaning of the pressing tool	17
Operation via the display unit of the PP40	18
Symbols in the display unit	18
Setting possibilities via the display menu	19
Languages	19
False language selection	19
Manual operation	19
Press programme	19
Pressing time	19
Pressing force	20
Starting time	21
Service	21
Contrast / Brightness	21
Date / Time	21
Stand-by monitor	21
Fault signals in the display	22
F02 to F31	22
General	23
Cleaning	23
Maintenance (monthly)	23
Wearing parts	23
Copyright	23
Alterations	23
Appendix	following pages

Notes on these operating instructions

These operating instructions for the pellet press, type PP40, give all the necessary information with regard to the areas mentioned in the contents.

Instructions are given for the definite target group(s) in each area, in order to ensure safe operation of the PP40 for its intended purpose. Knowledge of the relevant section is essential for safe, proper handling in each target group or groups.

This technical documentation is intended as a reference and instruction manual. The individual sections are complete in themselves.

These operating instructions do not include repair instructions. If repairs are necessary please contact your supplier or Retsch GmbH direct.

<http://www.retsch.com>

Warning instructions

Warnings are given by the following symbols:



Injury to persons



Damage to equipment



Follow the instructions for use

Repairs

These operating instructions do not include repair instructions. For your own safety repairs must be carried out only by Retsch GmbH, an authorised agent or by Retsch service technicians.

In this case please contact:

The Retsch agency in your country
Your supplier
Retsch GmbH directly

Your service address:

Safety

The PP40 is an ultra-modern, highly efficient product of Retsch GmbH, and corresponds to state of the art. If the machine is used according to the intended purpose with a knowledge of this technical documentation it is completely safe and reliable to operate.

Safety instructions

As the operating authority it is your duty to ensure that all persons charged with working on the PP40:

- have read and understood all the instructions on safety,
- from the beginning of work know all the instructions and regulations for the target group relevant to their work,
- have access to the technical documentation for this machine at all times without problems.
- New personnel should be familiarized with safe, proper handling of the machine before beginning work on the PP40, either by verbal instruction from a competent person or through this technical documentation.
- Improper operation can cause injury to persons or damage to the equipment. You are responsible for your own safety and that of your employees.
- Ensure that no unauthorized persons have access to the PP40.

For your own safety have your employees confirm that they have been instructed in operation of the PP40. The draft of a suitable form is given at the end of the section on safety.



We exclude any claims for damages of any kind for injury to persons and damage to equipment arising from non-observance of the following safety instructions.

Safety instructions – summarised, part 1

Safety instructions



We exclude any claims for damages of any kind for injury to persons and damage to equipment arising from non-observance of the following safety instructions.



Use according to the intended purpose



Do not make any alterations to the machine and use only spare parts and accessories approved by Retsch. **Otherwise the Declaration of Conformity to the European directives declared by Retsch will lose its validity. Furthermore this will lead to loss of any kind of guarantee claims.**

Packing



Please keep the packing material for the duration of the guarantee period, since if you have a complaint and the equipment is returned in inadequate packing your guarantee claim is at risk.

Transport



The PP40 must not be knocked, shaken or thrown during transport. Otherwise the electronic and mechanical components can be damaged.



Lifting above head height is not permitted.

Temperature variations



If the PP40 is subjected to high temperature variations (e.g. during air transport) it must be protected against condensed water. Otherwise there may be damage to the electronic components.

Supplied items



If the supplied items are incomplete and/or there is transport damage you must inform the transporter and Retsch GmbH immediately (within 24 hrs). Later complaints may possibly be no longer considered.

Ambient temperature



If the temperature drops below or exceeds ambient temperature the electrical and mechanical components can become damaged and performance data can change to an unknown extent.

Atmospheric humidity



At high atmospheric humidity the electrical and mechanical components can become damaged and performance data can change to an unknown extent.

Electrical connection



If the values on the type plate are not observed the electrical and mechanical components can become damaged.



Only a qualified electrician should carry out electrical connection. **Danger through current surge.**

Important instructions for electrical connection



If your mains connection for the PP40 includes a fault-current protective system, fault throwing may result through the anti-interference wiring of the frequency converter when this is switched on (switching on takes place each time the pressing chamber hood is closed).



If the values on the type plate are not observed this can result in damage to the electrical and mechanical components.

Serial interface



The serial interface cables must not be longer than 2.5 m. If the cables are longer this can result in disturbances during transmission of data.

Connecting the power supply



If the values on the type plate are not observed the electrical and mechanical components can become damaged.

Opening / closing / emergency unlocking



The emergency unlocking device must never be operated when the machine is running – only when the machine is at a standstill and is disconnected from the mains supply.

Danger of injury through pressing.

Insertion of the pellet press ring at the PP40



Use only the specified pellet press ring size.

Mechanical components can become damaged through using wrong ring sizes.

Preparation of the press process



Please take necessary measures, depending on the dangerous nature of your pressing material, to avoid danger to persons.



Check the quality of the press rings regularly.

Damaged rings can cause a damage to press tool.



The filling quantity shall be 8 – 12 ml.

The rings and press tool used could otherwise become damaged.

	<p>Pellet press ring filling level</p> <p>If the filling level of the pellet press ring is too high or too low the pressing result will be impaired.</p>
	<p>Please take such measures in accordance with the hazardousness of your sample material as to avoid any possible danger for persons coming into contact with it.</p>
	<p>Manual cleaning of the press tool</p> <p>To avoid analyses falsifications, the upper and bottom punch (press tool) must be cleaned after each press process, by using a soft cloth and a vacuum cleaner.</p>
	<p>Pressing force</p> <p>For press ring $\varnothing 40/35 \times 14$ the pressing force is limited to 20 t. (A higher pressing force can cause a deformation of the ring and a destruction of the pellet).</p>
	<p>Starting Time</p> <p>Even though starting without the lid closed is not possible, make sure that the lid is closed before you start the machine unattended.</p>
	<p>Cleaning</p> <p>Do not clean the PP40 with running water. Danger to life through current surge. Use only a cloth moistened with water. Solvents are not permitted.</p>
	<p>Maintenance</p> <p>Easy running of roller 1 on the closing pin is necessary for reliable closing via the automatic closing mechanism of the PP40.</p>
	<p>Wearing parts</p> <p>These operating instructions do not include repair instructions. For your own safety repairs should be carried out only by Retsch GmbH, an authorized agent or service technicians.</p>

Confirmation

I have taken note of the section „Notes on these operating instructions” and the section on “Safety”

Signature of operating authority

Signature of service technician

Technical data

Machine type designation: PP40

Use according to the intended purpose

The Retsch Pellet Press is used for a quick pressing of different minerals, slag, ores, cement, raw material, etc..

Soil samples, ores, coal, coke, corundum, metal oxides, minerals, plant samples, slag, silicates, cement and many other substances can be pressed, easily, quickly and without loss. These pellet press is used successfully in practically all areas of industry and research, particularly where stringent requirements are set on purity, quickness, fineness and reproducibility.

The PP 40 pallet press may only be used as a laboratory apparatus. A max 12 pressing cycles per hour in one-shift operation with 8 hours of working time are permissible.



Do not make any alterations to the machine and use only spare parts and accessories approved by Retsch. Otherwise the Declaration of Conformity with the European directives declared by Retsch loses its validity. **Furthermore this will result in the loss of any kind of guarantee claims.**

Pressing nominal volume

Depending on material: 8 – 12 ml

The following ring sizes or aluminum cups can be used:

- Ring Ø 51,5 / 35x8,6
- Ring Ø40 / 32x14
- Ring Ø40 / 35x14 and
- Aluminum cups Ø40x8

For ring Ø40/35x14 the pressing force is limited to 20 t.

Maximum charged grain size

Maximum charged grain size: < 100 µm

Driving power

1500 W

Press force

Depending on the model the press force averages between 5 – 40 t (for rings ø40/35x14 max. 20 t).

Hydraulic pressure

Max. 320 bar



Emissions

Noise characteristic values of PP40:

Noise measurement according to DIN 45635-31-01-KL3

The noise characteristic values are influenced mainly by the hydraulic aggregate.

Workplace-related emission value L_{pAeq} = up to 66 dB(A)

Systems of protection

IP40

Protective equipment

The PP40 is fitted with an automatic lid shutting device which prevents the machine being started in an unsafe condition. The machine can be started only with the lid closed.

The lid can be opened only when the machine is at a standstill.

Mode of operation

S1

Operation with constant load, the duration of which is sufficient for the thermal steady state condition to be reached (DIN VDE 0530 T1)

The PP 40 pallet press may only be used as a laboratory apparatus. A max 12 pressing cycles per hour in one-shift operation with 8 hours of working time are permissible.

Machine dimensions

Height: up to approx. 1220 mm / width: 820 mm / depth: up to approx. 780 mm

Weight : PP40 net approx. 360 kg

Required floor space

Height (open hood): 1930 mm / width: 820 mm / depth: 780 mm;

A safety distance of 100 mm on the rear side is necessary so that the main switch can be operated.

Transport and installation

Packing

Packing is adapted to the transport route and conforms to the generally applicable packaging guidelines.



Please keep the packing material for the duration of the guarantee period since if there is a complaint and the machine is returned with inadequate packing your guarantee claim will be at risk.

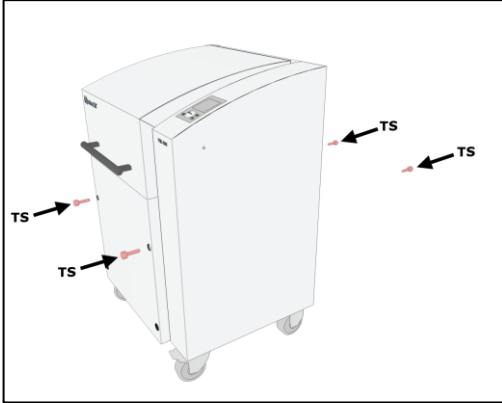

Fig. 1 Fitting the transport screws

Transport

The PP40 (360 kg) is to be lifted and transported only by the transport screws **TS** supplied with the machine. (Fig. 1 Fitting the transport screws)

Net weight of PP40 approx. 360 kg



Lifting above head height is not permitted.

The PP40 must not be knocked, shaken or thrown during transport. Otherwise the electronic and mechanical components can become damaged.

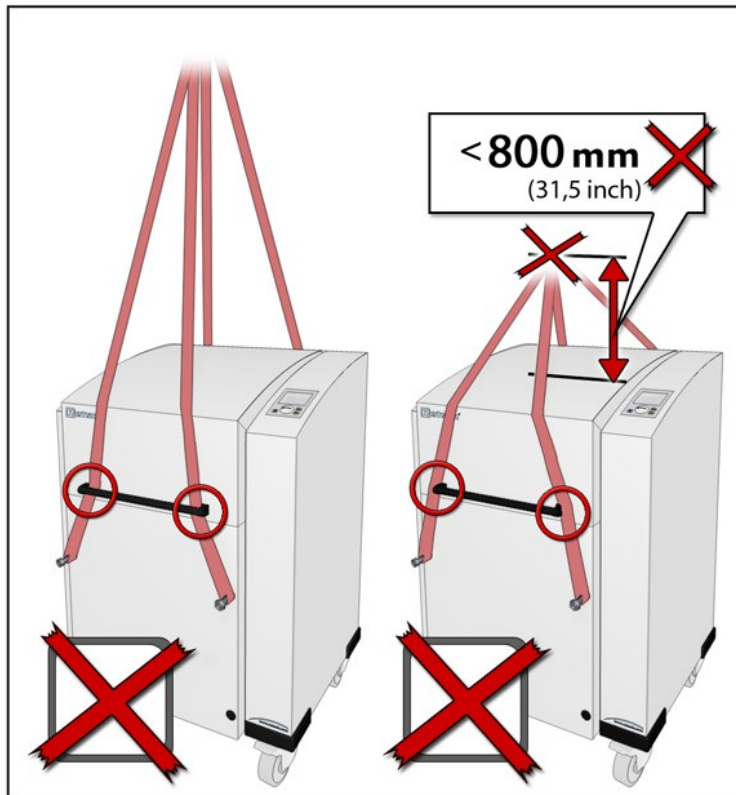
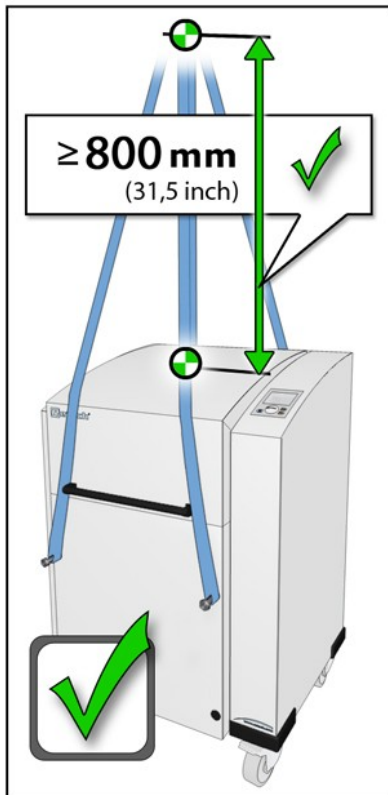

Temperature variations



If temperature variations are high (e.g. during air transport) the PP40 must be protected against condensed water. Otherwise the electronic components can become damaged.

Intermediate storage

Ensure that the PP40 is also stored dry during intermediate storage.

Erection

Erect the PP40 on a firm base. Further parameters are given in the section „Technical data“.

Net weight of PP40: approx. 360 kg

The machine must be locked in position before starting up. For this purpose press the locking lever **F** of the two front rollers downwards.

(Fig. 2 Locking lever)

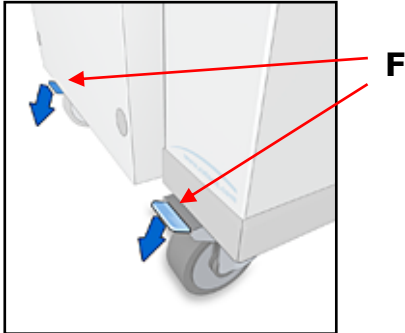

Fig. 2 Locking lever

Parameters for the place of installation

Ambient temperature: 5°C to 40°C



If the ambient temperature drops below or exceeds these values the electrical and mechanical components can become damaged and performance data are changed to an unknown extent.

Atmospheric humidity

Maximum relative humidity = 80% at temperatures up to 31°C, decreasing linearly down to 50% relative humidity at 40°C.



At higher atmospheric humidity the electrical and mechanical components can become damaged, and performance data are changed to an unknown extent.

Installation height: max. 2000 m above sea level

Electrical connection

- Voltage and frequency for the PP40 are given on the type plate.
- Ensure that these values correspond to the available power supply system.
- Connect the PP40 to the power supply system using the supplied connection cable.
- Protection by external fusing is to be carried out when connecting the mains cable to the power supply, according to the regulations at the place of installation.



If the values on the type plate are not observed this can cause damage to the electronic and mechanical components.



Only a qualified electrician should carry out electrical connection. **Danger through current surge.**

Important instructions for electrical connection

1. Electrical connection without a protective conductor PE is not permissible.
2. The drive of your PP40 is fitted with a frequency converter. To fulfill the EMC directive this is fitted with a line filter and shielded cables to the motor.



If your mains connection for the PP40 includes a fault-current protective system, fault throwing may result through the anti-interference wiring of the frequency converter when this is switched on (switching on takes place each time the pressing chamber hood is closed).

This can occur without there being a fault on your PP40 or your mains installation.

According to state of the art selective a.c.-d.c. sensitive fault-current protective systems are recommended for such cases. The tripping current must be adequately dimensioned since capacitive compensating currents occurring only for a short time (shielded cables, line filter) when switching on can easily cause fault throwing.

Under certain circumstances it may be necessary to operate the PP40 without a fault-current protective system. In this case, however, it should be checked whether this is inconsistent with the local regulations of the electricity supply company or other applicable institutions or standards.



If the values on the type plate are not observed this can result in damage to the electrical and mechanical components.

Serial interfaces

- Inactive interface **Sc** for optional data communication with an external device. This necessitates updating of the software.
(Fig. 3 Serial interface)

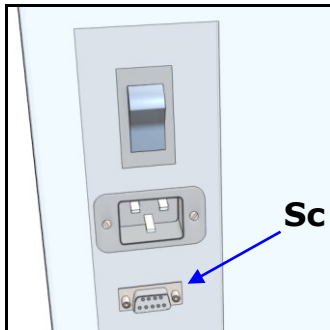

Fig. 3 Serial interface



The interface cables must not be longer than 2.5 m. Longer cables can cause disturbances during transmission of data.

Operation

Connecting the power supply

Ensure that the voltage and frequency of your mains supply correspond to the values on the type plate of the PP40. The mains supply must be fused up to at least 16A.
(Fig. 4 Receiving socket and main switch)

- Plug the mains cable into the receiving socket **Au** on the rear side of the equipment.
- Plug the mains plug into the mains socket.
- Switch on the main switch **H**.

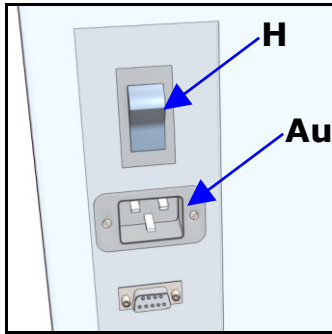

Fig. 4 Receiving socket and main switch



If the values on the type plate are not observed this can result in damage to the electrical and mechanical components.

When the PP40 is switched on for the first time the language menu is displayed.

The language of your country must now be selected by turning the control knob **E**. By pressing this knob selection is confirmed and the display shows "Open lid".
(Fig. 5 Control panel)

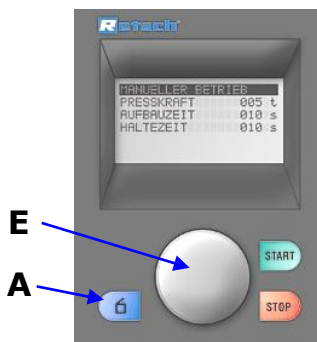



Fig. 5 Control panel

Opening / closing / emergency unlocking

Opening

The following steps are necessary in order to press a pellet:

- Connect PP40 to the mains supply
- Switch on the main switch on the rear side
- Press button **A** - 

The safety-closing device opens and the lid **D** can be swung open. The pressing chamber is now freely accessible.

Closing

Locking the pressing chamber is possible only if the PP40 is connected to the mains supply and the main switch on the rear side of the machine is switched on.

- Close the housing lid **D**
(Fig. 6 Housing lid)

A sensor senses the closing pin of the housing lid and the motor-driven lid closing mechanism is switched on.

The housing lid **D** is automatically locked.



Fig. 6 Housing lid

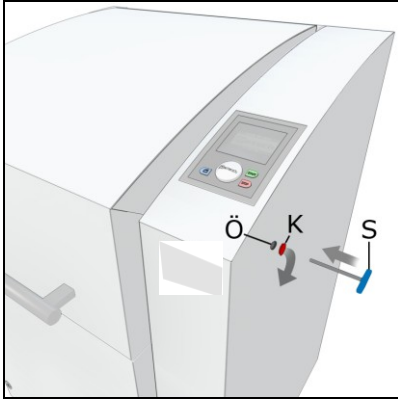

Fig. 7 Emergency unlocking

Emergency unlocking

A key for the machine is included in the delivery, with which the PP40 can be manually opened if there is a power failure. (Fig. 7 Emergency unlocking)

- Remove cap **K**
- **(I)** Insert the **(S)** key into the **(Ö)** opening on the right-hand side.
- **(II)** To unlock the gear, the key must be pushed in further with some degree of force. While pushing the key in, turn it in a clockwise direction as far as it will go.

The cover can now be opened.



The emergency unlocking device must never be operated when the machine is running – only when the machine is at a standstill and is disconnected from the mains supply.

Danger of injury through pressing

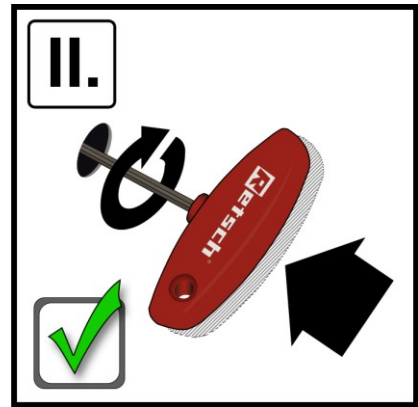
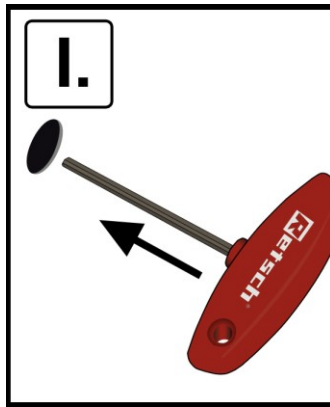

Before starting the PP40

The press device has proved itself for many years, and is easy and reliable to handle. In order to guarantee the safety of the operator and a long service life of the machine components the press rings must be inserted and filled carefully. Please remember that the PP40 is a pellet press with a very high pressing power requiring a careful insertion of the press rings.

Insertion of pellet press rings and aluminum cups of the PP40

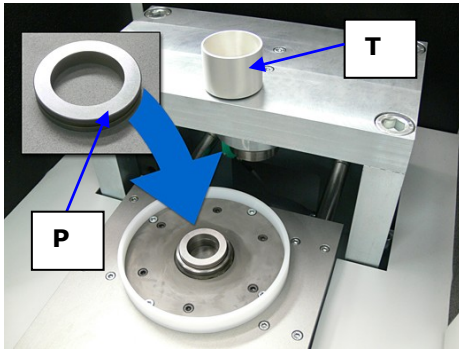

Fig.8 Insertion of pellet press rings

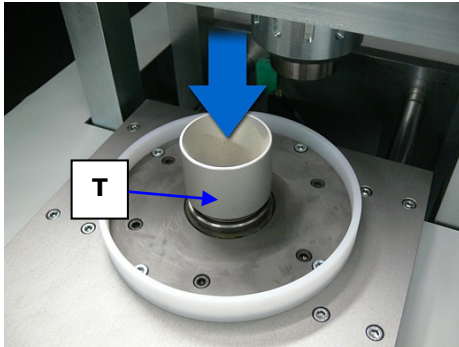

Fig.9 Filling funnel

The press ring **P** or the aluminum cup will be placed into the press tool by hand in the front position of the tool slide and will be filled with sample material. (Filling funnel **T** to be used) The filling quantity ranges from 8 to 12 ml, depending on the material.

During sample preparation, the material to be pressed can be mixed with a standard binder.

The tool slide must be moved into the pressing position (in the back), it locks into place and the housing lid must be closed.



Only start the PP40 with the provided rings or alu cups.
Mechanical components can become damaged.

Preparation of the pressing process

- Place the tool slide into the filling or cleaning position.
- Place the press ring into the die of the press tool.
- Fill in the sample material by means of the filling funnel. Pay attention that no material is laying on the ring rim. Remains on the ring rim can be removed by means of a brush.
- Put aside the filling funnel and push the tool slide into the pressing position slowly and steadily. The slide locks into place.
- You can then close the hood and start the PP40.



Please take necessary measures, depending on the dangerous nature of your pressing material, to avoid danger to persons.

Check the quality of the press rings regularly.
Damaged rings can cause a damage to press tool.

The filling quantity shall be 8 – 12 ml.
The rings and press tool used could otherwise become damaged.

Pellet press ring filling level



If the filling level of the pellet press ring is too high or too low the pressing result will be impaired.

Please take such measures in accordance with the hazardousness of your sample material as to avoid any possible danger for persons coming into contact with it.

Parameter Setting Example

Sample: cement clinker

Pellet press ring filling level

net weight:

ring 51,5 / 35 x 8,6 approximately 12g
ring 40 / 32 x 14 approximately 14g

force progression:

pressing force	ca. 12 t
build-up time	20 s
holding time	20 s
release time	20 s

The values of this example are an example and may vary depending on cement clinker and pressing tools .

Removal of the pellet

To remove the pellet, the sliding tray is pulled into the position for cleaning and snaps in audibly. The display shows "Cleaning".

By pressing the START key the pellet is pressed out of the pressing tool and can be removed. The display shows "START = Continue".

Clean the pressing tool (please refer to the following chapter "Manual cleaning of the pressing tool").

After cleaning the pressing tool, the pressing stamp is moved to the filling position by pressing the START key.

Manual cleaning of the pressing tool

After having removed the pellet, material residues must be removed manually from the pressing tool. The contact area of the ring, the pressing stamp and the upper stamp should be cleaned with a cloth.

Press the START key to finalize the cleaning.



To avoid analyses falsifications, the upper and bottom punch (press tool) must be cleaned after each press process, by using a soft cloth and a vacuum cleaner.

Operation via the display unit of the PP40

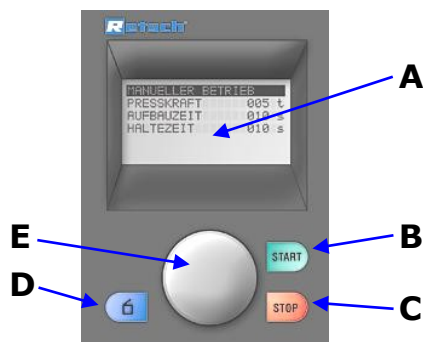

Fig. 10 Control panel

The pellet press has a new, very comfortable operator control system. All relevant data can be entered or called via a graphic display with one knob operation. The menu system is multilingual. (Fig. 10 Control panel)

	Name	Function
A	Display	Displays the menu, parameter settings, operating instructions and fault signalling.
B	START button	Starts the pressing process
C	STOP button	Stops the pressing process
D	Button	Opens the pressing chamber hood
E	Setting knob	By turning and pressing, all menu points can be selected and parameters set. Turning 1 By turning, the various menu points can be selected. Selected menu points are displayed inversely. Turning 2 Setting of parameters in the opened menu points (see Pressing 1) Pressing 1 Selected menu points are opened Pressing 2 Short pressing confirms setting of parameters Pressing 3 Continuous pressing: jump back to the 1st menu level

Symbols in the display unit



Programme mode – Take over parameters



Programme mode – Delete programme



Service due



Hydraulic oil or frequency converter too hot



Fig.11 Control Panel

By turning and pressing the setting knob **E** all menu items can be selected and parameters can be set.

Turning 1

By turning the different menu items can be selected. Selected menu items are inversely represented.

Turning 2

Setting of parameters in opened menu items (please refer to Turning 1).

Pressing 1

Selected menu items are opened.

Pressing 2

Short pressing confirms the setting of the parameters.

Pressing 3

By constant pressing you return to the 1st menu level.

Setting possibilities via the display menu

For setting possibilities on the display described below please observe the menu structure on this page. The selection bar in the display should be operated as follows:



- Vertical manoeuvring through the structure by **turning** the setting knob
- Horizontal manoeuvring through the menu structure by **pressing** the setting knob
- Setting of numerical values or decisions by **turning** the setting knob
- Confirmation of settings by **pressing** the setting knob
- With "RETURN" you go to the previous menu structure level
- By **continuous pressing** of the setting knob you return to the basic screen

Languages		
Menu	Display	Languages

You can select the language here. After selection and pressing the setting knob the complete menu structure is shown in this language.

False language selection

If the wrong language is accidentally selected switch off the unit at the main switch.

Keep the buttons    pressed simultaneously and switch on the unit again. After selecting the correct language switch off the equipment and then immediately on again. Confirm your selection by pressing the setting knob. The unit is now set permanently in your language and you are in the main menu.

Manual operation

If this function is set you can call and change all parameters and functions at any time. This is also possible during milling.

Press programme

- To get to the „Pressing programme“ function press the setting knob with "Manual operation" set. Pressing programme 1 appears, flashing, in the display. Furthermore data which may already have been stored in pressing programme 1 are also displayed.
- By turning the setting knob to the right you can select other pressing programmes 2-32. Any parameters which may have been stored are displayed each time.
- You can start the machine directly with the selected milling programme.
- To return to „manual operation“ turn the setting knob completely to the left and confirm with the setting knob.

Pressing time

00:00:01 to 99:59:59
Hours: Minutes: Seconds



The PP40 is started with the preselected pressing time.

Pressing force	5 – 40 T
-----------------------	----------

START	The PP40 is started with the preselected pressing time and the preselected pressing force.
--------------	--



For press ring $\varnothing 40/35 \times 14$ the pressing force is limited to 20 t. (A higher pressing force can cause a deformation of the ring and a destruction of the pellet).



Fig.12



START	The PP40 is started with the preselected pressing force and pressing time.
--------------	--

Programme mode		
	Take over parameters	Here all the previously set parameters, such as pressing force, pressing time, build-up time, holding time, decreasing time, can be stored in a store.
	<ul style="list-style-type: none"> Set the required parameter. Change to „Programme mode“ in the menu, press the setting knob and confirm „Take over parameters“ again. The menu shows „Pressing programme“ and on the right the storage location number. Turn the setting knob to the right until you have found a pressing programme with empty storage locations, or one which you wish to overwrite. By pressing the setting knob you can reserve the selected storage location. You can now choose between „Store parameter?“ or „Cancel“. You will then be returned again into the “Programme mode” level. 	

Programme mode		
	Change programme	Here all previously stored parameters, such as pressing force, build-up time, holding time, decreasing time, can be changed. It is also possible to enter new parameters.
	<p>Select „Programme mode“, „Change programme“ and confirm with the setting knob. The display shows the pressing programme with storage location number again.</p> <ul style="list-style-type: none"> To select the „Pressing programme“ to be changed press the setting knob; only the storage location numbers are inverse – the pressing programme is changed by turning the setting knob. Confirm the milling programme to be changed by pressing; you can now change the parameters. After this you can „Store (the changed) parameters“ or „Cancel“. You will then be returned again to the “Programme mode” level. 	

Programme mode		
	Delete programme	Here all the previously stored parameters can be deleted.
	<ul style="list-style-type: none"> Select „Programme mode“, press the setting knob and confirm „Delete programme“ again. Select the pressing programme to be deleted by turning the setting knob, and confirm by 	

	pressing. <ul style="list-style-type: none"> You can now "Delete programme" or "Cancel". You will then be returned again to the programme mode level
--	--

Starting time	Start in xxh xxm	Starting can be preselected here in steps of 01 to 99 hrs or 01 to 60 min.
Cancel		
	The PP40 is started with the preselected parameters after the set starting time has elapsed.	
	Even though starting without the lid closed is not possible, make sure that the lid is closed before you start the machine unattended.	
	You can interrupt running of the starting time at any time with the STOP button and with the main switch on the rear side of the unit. You then have to reprogramme the starting time.	

Service

MENU	SETTINGS
-------------	-----------------

The service menu is divided into four sub-menus:

- OPERATING HOURS**
 The pressing hours are counted, i.e. the total sum of the times between START and STOP. These times cannot be manipulated.
- OPERATING SOFTWARE**
 The operating software version can be interrogated and, if necessary, updated. When required please contact your Retsch distributor.
 If you have accidentally got into the menu and jumping back into the previous menu is not possible, switch off the unit at the main switch and restart.

Contrast / Brightness

MENU	DISPLAY	CONTRAST
		BRIGHTNESS

Contrast and brightness can be adapted to each user or to the environment (sunlight, dazzling etc). If you have accidentally selected the wrong contrast or brightness (the display can no longer be seen), switch off the unit at the main switch, keep the buttons START, STOP and LID OPEN pressed simultaneously and switch on again. You are now in the language selection and the setting values CONTRAST and BRIGHTNESS have the works presettings again.

Date / Time

MENU	DATE
	TIME

The actual date and time can be entered here. The time then appears in the stand-by monitor. The unit can be disconnected from the mains for up to 30 days without the settings being lost.

Stand-by monitor

After 15 minutes inactivity of the unit (times after a STOP command) the stand-by monitor switches on automatically. By pressing one of the buttons, or touching the setting knob, the stand-by monitor disappears without carrying out the command which has been made. If you were in a sub-menu when the stand-by monitor was activated, you return to this selection window automatically. The stand-by monitor cannot be set and cannot therefore be switched off.

Fault signals in the display

F02 to F31

	Appearing in display F03 Open or close lid, otherwise lid lock defective Service necessary!
Appearing in display F04 Open or close the lid, otherwise the lid lock is defective Service necessary!	Appearing in display F07 Motor control Is defective Service necessary!
	Appearing in display F15 Problem in Safety circuit of the Frequency converter Service necessary!
Appearing in display F18 Problem in safety circuit of transformer Service necessary!	Appearing in display F26 Frequency converter is overheated No start possible Please allow to cool
Appearing in display F30 NO OIL PRESSURE Appearing in display Service necessary!	Appearing in display --- Oil is overheated No start possible Please allow to cool Appearing in display

General

Cleaning



Do not clean the PP40 with running water.
Danger to life through current surge.
Use only a cloth moistened with water. Solvents are not permitted.

Maintenance (monthly)

In order to guarantee operating reliability of your PP40 the following maintenance work should be carried out from time to time, however at the latest monthly:

- Check roller **1** of the closing pin for easy running and oil if necessary, e.g with sewing machine oil.
(Fig.13 Closing pin)
- Clean magnets **2** on closing pin.

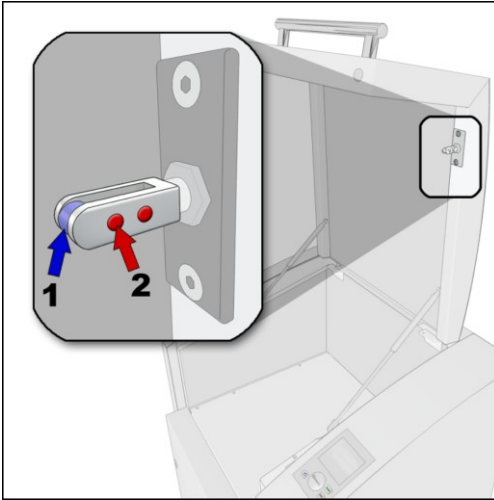

Fig.13 Closing pin



Easy running of the roller **1** on the closing pin is necessary for reliable closing of the housing lid of the PP40.

Wearing parts



These operating instructions do not include repair instructions. For your own safety repairs should be carried out only by Retsch GmbH, an authorised agent or service technicians.

Copyright

Distribution or duplication of this documentation, using or passing on the contents, is allowed only with the express permission of Retsch GmbH.

Persons violating are liable to pay damages.

Alterations

Subject to technical alterations without notice.

PELLET PRESS

PP 40

Certificate of CE-Conformity according to:

EC Mechanical Engineering Directive 2006/42/EC

Applied harmonized standards, in particular:
DIN EN ISO 12100 Security of machines

EC Directive Electromagnetic Compatibility 2004/108/EC

Applied standards, in particular:

EN 61000-3-2/-3 Electromagnetic compatibility (EMC)
EN 61236 Electrical measuring, operating, controlling and laboratory equipment – EMC-requirements in conjunction with EN 61000

EN 55011 Limit values and measuring procedures for noise suppression of industrial, scientific and medical high frequency devices

Additional applied standards, in particular

DIN EN 61010 Safety prescriptions concerning measuring-, operating-, controlling- and laboratory equipment

Authorized person for the compilation of technical documents:

J. Bunke (technical documentation)

The following records are held by Retsch GmbH in the form of Technical Documentation:

Detailed records of engineering development, construction plans, study (analysis) of the measures required for conformity assurance, analysis of the residual risks involved and operating instructions in due form according to the approved regulations for preparation of user information data.

The CE-conformity of the Retsch Pellet Press Type PP 40 is assured herewith.

In case of a modification to the machine not previously agreed with us as well as the use of not licensed spare parts and accessories this certificate will lose its validity.

Retsch GmbH

Haan, January 2010

Dr. Stefan Mähler
Manager technical services





Copyright

© Copyright by
Retsch GmbH
Haan, Retsch-Allee 1-5
D-42781 Haan
Federal Republic of Germany