

# Manual

## Sample Divider PT200



Translation

**Retsch**<sup>®</sup>

## **Copyright**

© Copyright by  
Retsch GmbH  
Haan, Retsch-Allee 1-5  
D-42781 Haan  
Federal Republic of Germany

<b>1</b>	<b>Notes on the Operating Manual .....</b>	<b>5</b>
1.1	Explanations of the safety warnings .....	6
1.2	General safety instructions .....	7
1.3	Repairs.....	8
<b>2</b>	<b>Confirmation .....</b>	<b>9</b>
<b>3</b>	<b>Transport, scope of delivery, installation .....</b>	<b>10</b>
3.1	Packaging .....	10
3.2	Transport.....	10
3.3	Temperature fluctuations and condensed water .....	10
3.4	Conditions for the place of installation .....	10
3.5	Installation of the machine .....	10
3.6	Type plate description.....	10
3.7	Electrical connection .....	11
<b>4</b>	<b>Technical data.....</b>	<b>11</b>
4.1	Use of the machine for the intended purpose.....	12
4.2	Emissions.....	12
4.3	Degree of protection .....	12
4.4	Drive output.....	12
4.5	Rotation speed.....	12
4.6	Rated power .....	12
4.7	Feed size .....	13
4.8	Receptacle volume .....	13
4.9	Dimensions and weight.....	13
4.10	Required floor space.....	14
<b>5</b>	<b>Operating the machine .....</b>	<b>14</b>
5.1	Views of the Instrument .....	14
5.2	Overview table of the parts of the device .....	16
5.3	Operating elements and displays .....	18
5.4	Overview Table of the Operating Elements and the Display.....	18
5.5	Frame assembly .....	18
5.6	Switching On and Off.....	19
5.7	Inserting bottom cone .....	20
5.8	Inserting sample vessel .....	20
5.8.1	Inserting the sample container into the quick-release sample outlet.....	21
5.9	Starting, Interrupting, Stopping .....	22
5.10	Process Run Duration.....	22
5.11	Attaching vibratory feeder.....	22
5.12	Creating interface connection .....	23

5.13	Starting device and vibratory device simultaneously.....	24
5.14	Setting the sample slot width.....	25
5.15	Calculating the slot width.....	26
5.15.1	Sample nozzle – Opening width.....	26
5.15.2	Determining the minimum opening width.....	27
5.16	Replacing the machine fuses.....	27
<b>6</b>	<b>Cleaning and service .....</b>	<b>28</b>
<b>7</b>	<b>Fault messages.....</b>	<b>28</b>
<b>8</b>	<b>Disposal.....</b>	<b>29</b>
<b>9</b>	<b>Index .....</b>	<b>30</b>
<b>10</b>	<b>Appendix .....</b>	<b>following pages</b>

## 1 Notes on the Operating Manual

This operating manual is a technical guide on how to operate the device safely and it contains all the information required for the areas specified in the table of contents. This technical documentation is a reference and instruction manual. The individual chapters are complete in themselves.

Familiarity (of the respective target groups defined according to area) with the relevant chapters is a precondition for the safe and appropriate use of the device.

This operating manual does not contain any repair instructions. If faults arise or repairs are necessary, please contact your supplier or get in touch with Retsch GmbH directly.

Application technology information relating to samples to be processed is not included but can be read on the Internet on the respective device's page at [www.retsch.com](http://www.retsch.com).

### Changes

Subject to technical changes.

### Copyright

Disclosure or reproduction of this documentation, use and disclosure of its contents are only permitted with the express permission of Retsch GmbH.

Infringements will result in damage compensation liability.

## 1.1 Explanations of the safety warnings

In this Operating Manual we give you the following safety warnings

---

**Serious injury** may result from failing to heed these safety warnings. We give you the following warnings and corresponding content.



### WARNING

**Type of danger / personal injury**

Source of danger

- Possible consequences if the dangers are not observed.
- **Instructions on how the dangers are to be avoided.**

---

We also use the following signal word box in the text or in the instructions on action to be taken:



### WARNING

---

**Moderate or mild injury** may result from failing to heed these safety warnings. We give you the following warnings and corresponding content.



### CAUTION

**Type of danger / personal injury**

Source of danger

- Possible consequences if the dangers are not observed.
- **Instructions on how the dangers are to be avoided.**

---

We also use the following signal word box in the text or in the instructions on action to be taken:



### CAUTION

---

In the event of possible **property damage** we inform you with the word “Instructions” and the corresponding content.

### NOTICE

**Nature of the property damage**

Source of property damage

- Possible consequences if the instructions are not observed.
- **Instructions on how the dangers are to be avoided.**

---

We also use the following signal word in the text or in the instructions on action to be taken:

*NOTICE*

## 1.2 General safety instructions

 **CAUTION**

**Read the Operating Manual**

Non-observance of these operating instructions

- The non-observance of these operating instructions can result in personal injuries.
- **Read the operating manual before using the device.**
- **We use the adjacent symbol to draw attention to the necessity of knowing the contents of this operating manual.**



**Target group :** All persons concerned with the machine in any form

This machine is a modern, high performance product from Retsch GmbH and complies with the state of the art. Operational safety is given if the machine is handled for the intended purpose and attention is given to this technical documentation.

You, as the owner/managing operator of the machine, must ensure that the people entrusted with working on the machine:

- have noted and understood all the regulations regarding safety,
- are familiar before starting work with all the operating instructions and specifications for the target group relevant for them,
- have easy access always to the technical documentation for this machine,
- and that new personnel before starting work on the machine are familiarised with the safe handling of the machine and its use for its intended purpose, either by verbal instructions from a competent person and/or by means of this technical documentation.

Improper operation can result in personal injuries and material damage. You are responsible for your own safety and that of your employees.

Make sure that no unauthorised person has access to the machine.

 **CAUTION**

**Changes to the machine**

- Changes to the machine may lead to personal injury.
- **Do not make any change to the machine and use spare parts and accessories that have been approved by Retsch exclusively.**

### NOTICE

**Changes to the machine**

- The conformity declared by Retsch with the European Directives will lose its validity.
- You lose all warranty claims.
- **Do not make any change to the machine and use spare parts and accessories that have been approved by Retsch exclusively.**

### 1.3 Repairs

This operating manual does not contain any repair instructions. For your own safety, repairs may only be carried out by Retsch GmbH or an authorized representative or by Retsch service engineers.

**In that case please inform:**

The Retsch representative in your country
Your supplier
Retsch GmbH directly

**Your Service Address:**



## 2 Confirmation

This operating manual contains essential instructions for operating and maintaining the device which must be strictly observed. It is essential that they be read by the operator and by the qualified staff responsible for the device before the device is commissioned. This operating manual must be available and accessible at the place of use at all times.

The user of the device herewith confirms to the managing operator (owner) that (s)he has received sufficient instructions about the operation and maintenance of the system. The user has received the operating manual, has read and taken note of its contents and consequently has all the information required for safe operation and is sufficiently familiar with the device.

As the owner/managing operator you should for your own protection have your employees confirm that they have received the instructions about the operation of the machine.

I have read and taken note of the contents of all chapters in this operating manual as well as all safety instructions and warnings.

**User**

Surname, first name (block letters)

Position in the company

Signature

**Service technician or operator**

Surname, first name (block letters)

Position in the company

Place, date and signature

### 3 Transport, scope of delivery, installation

#### 3.1 Packaging

The packaging has been adapted to the mode of transport. It complies with the generally applicable packaging guidelines.

#### 3.2 Transport

---

##### *NOTICE*

###### **Transport**

- Mechanical or electronic components may be damaged.
  - **The machine may not be knocked, shaken or thrown during transport.**
- 

#### 3.3 Temperature fluctuations and condensed water

---

##### *NOTICE*

###### **Temperature fluctuations**

The machine may be subject to strong temperature fluctuations during transport (e.g. aircraft transport)

- The resultant condensed water may damage electronic components.
  - **Protect the machine from condensed water.**
- 

#### 3.4 Conditions for the place of installation

---

##### *NOTICE*

###### **Ambient temperature**

- Electronic and mechanical components may be damaged and the performance data alter to an unknown extent.
  - **Do not exceed or fall below the permitted temperature range of the machine (5°C to 40°C / ambient temperature).**
- 

#### 3.5 Installation of the machine

Installation height: maximum 2000 m above sea level

#### 3.6 Type plate description



Fig. 1: Type plate lettering

- 1 Device designation
- 2 Year of production
- 3 Part number
- 4 Serial number
- 5 Manufacturer's address
- 6 CE marking
- 7 Disposal label
- 8 Bar code
- 9 Power version
- 10 Mains frequency
- 11 Capacity
- 12 Amperage
- 13 Number of fuses
- 14 Fuse type and fuse strength

In the case of questions please provide the device designation (1) or the part number (3) and the serial number (4) of the device.

### 3.7 Electrical connection

**⚠ WARNING**

When connecting the power cable to the mains supply, use an external fuse that complies with the regulations applicable to the place of installation .

- Please check the type plate for details on the necessary voltage and frequency for the device.
- Make sure the levels agree with the existing mains power supply.
- Use the supplied connection cable to connect the device to the mains power supply.

## 4 Technical data

 **CAUTION**

**Risk of explosion or fire**

- On account of its design, the device is not suitable for use in hazardous (potentially explosive) atmospheres.
- **Do not operate the device in a hazardous atmosphere.**

**4.1 Use of the machine for the intended purpose**

This device is suitable for the representative division and sampling of pourable, disperse products with a feed size up to a max. 10mm.

With a maximum feed size of 26 litres, a minimum fraction of 100ml should be observed.

In view of its mode of function this device is also suitable for installation in continuously operating preparation systems.

**NOTICE**

**Area of use of the machine**

- This machine is a laboratory machine designed for 8-hour single-shift operation.
- **This machine may not be used as a production machine nor is it intended for continuous operation.**

**4.2 Emissions**

**Noise details**

Noise measurement to DIN 45635-31-01-KL3

The noise values are also influenced by the properties of the sample material.

Example 1:

- Sound power level SWL = 69 dB(A)
- Emission value with regard to workplace LpAeq = 63 dB(A)

Operating conditions:

- Receptacle: glass bottle 500ml and collecting receptacle 26 litres
- Feed material: quartz approx. 0.1 – 3.0mm

**4.3 Degree of protection**

IP40

**4.4 Drive output**

Stepping motor

**4.5 Rotation speed**

50 revolutions per minute

**4.6 Rated power**

50 watt

**4.7 Feed size**

max. 10mm

**4.8 Receptacle volume**

- Glass bottles 250ml
- Glass bottles 500ml
- Collecting receptacle 26l

**4.9 Dimensions and weight**



Fig. 2: Dimensions PT200 incl. sample divider

**Dimensions without vibratory feeder**

Height: 1060mm

Width: 520mm

Depth: 551mm

### **Dimensions with vibratory feeder**

Height: 1307mm

Width: 572mm

Depth: 551mm

### **4.10 Required floor space**

Width: 520mm

Depth: 551mm

## **5 Operating the machine**

### **5.1 Views of the Instrument**

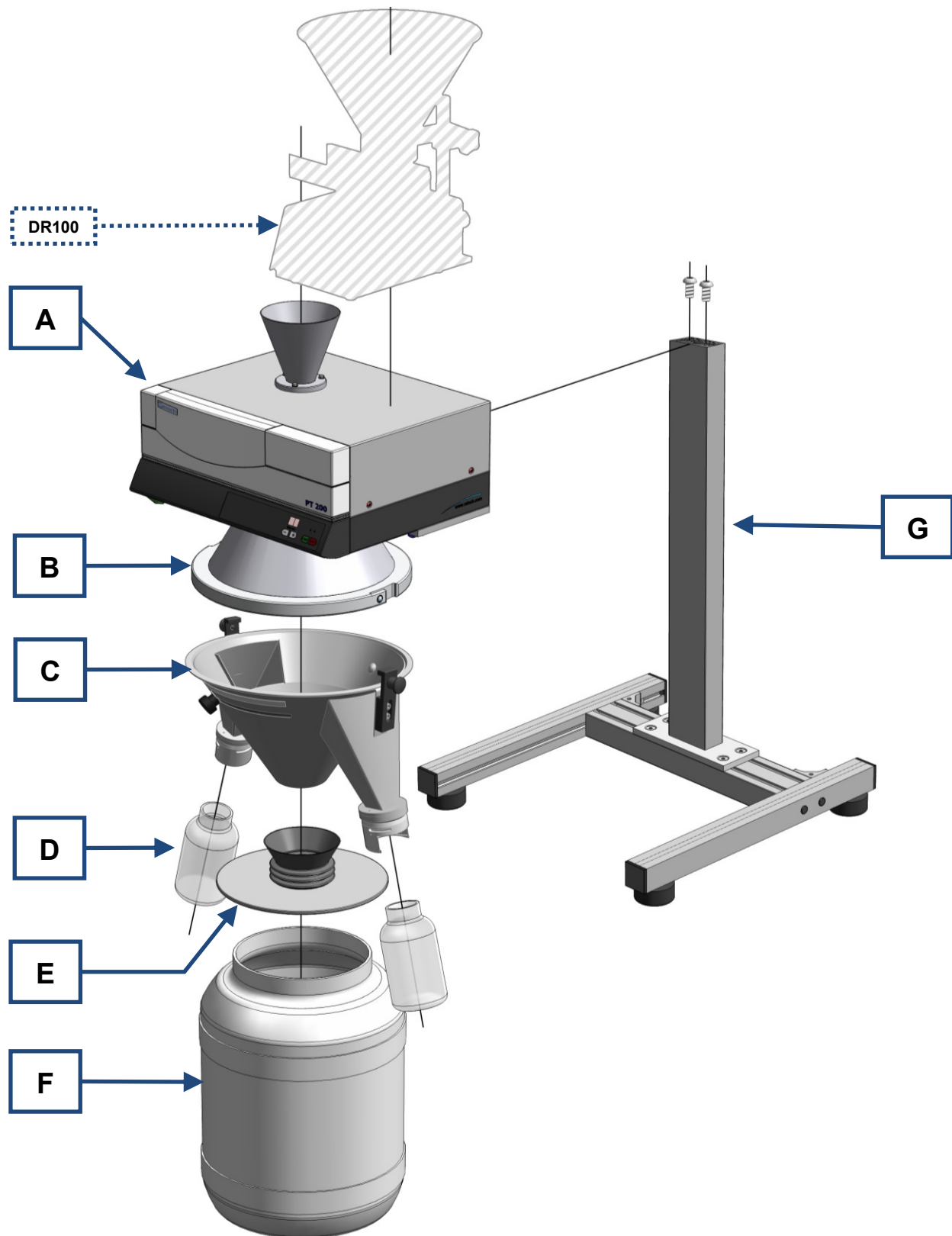

Fig. 3: General view of the device and the individual parts

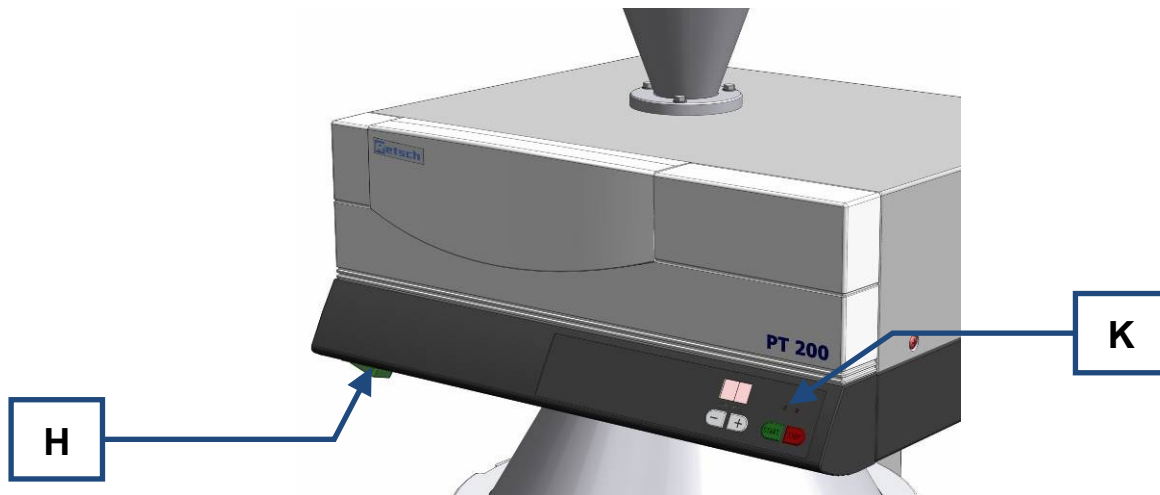

Fig. 4: View of the on/off switch and the control panel

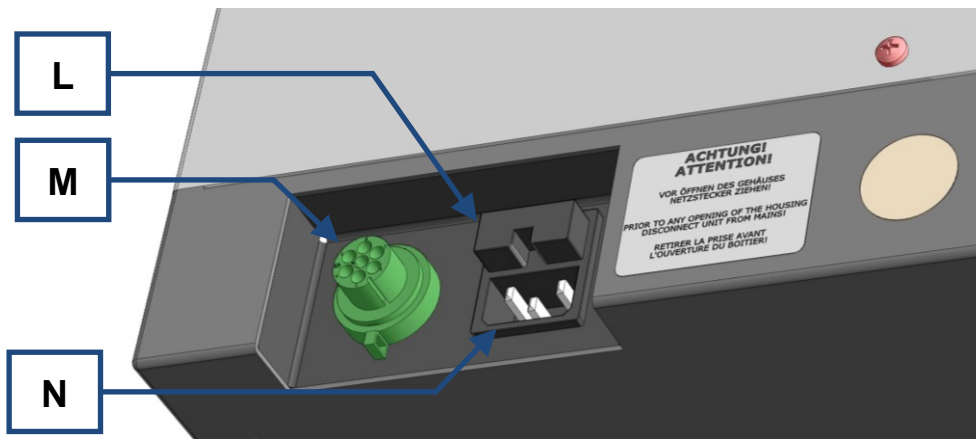

Fig. 3: Back of the device– Power connection and interface

## 5.2 Overview table of the parts of the device

Element	Description	Function
A	Housing	Drive and control unit
B	Top cone	Cover on the tube divider
C	Bottom cone	For fastening the sample container in place and adjusting the sample slot
D	Sample container	Collecting receptacle for the sub-samples
E	Lid for the reject collector	Cover and collecting hopper for the reject collector
F	Reject collector	Collecting receptacle for non-divided residual sample
G	Stand	Holder for the sample divider
H	Switch	On/off switch
K	Control panel	START, STOP buttons, time setting and display
L	Fuse tray	Contains two glass fuses
M	Interface to the vibratory feeder	Connection for the cable to the vibratory feeder



<b>N</b>	Plug connection	Connection for the mains power cable
----------	-----------------	--------------------------------------

### 5.3 Operating elements and displays

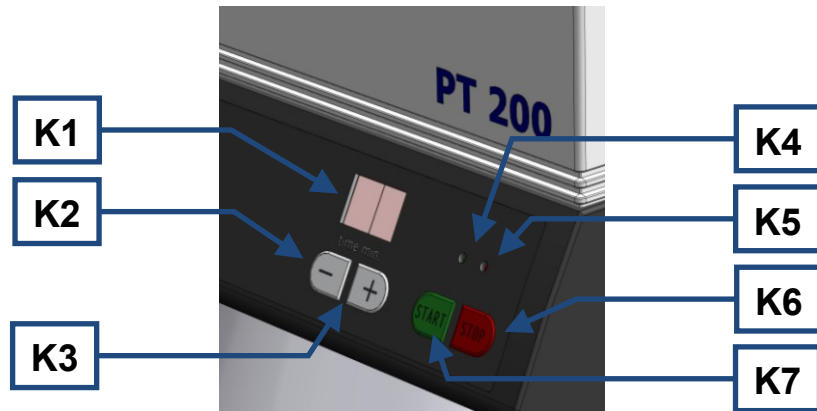

Fig. 5: Operating panel

### 5.4 Overview Table of the Operating Elements and the Display

Element	Description	Function
K1	Display	Display for set dividing time and error messages
K2	- button	Reduces dividing time
K3	+ button	Increases dividing time
K4	LED green	Display for device switched on / running
K5	LED red	Device stopped
K6	STOP key	Stops the device
K7	START key	Starts the device

### 5.5 Frame assembly

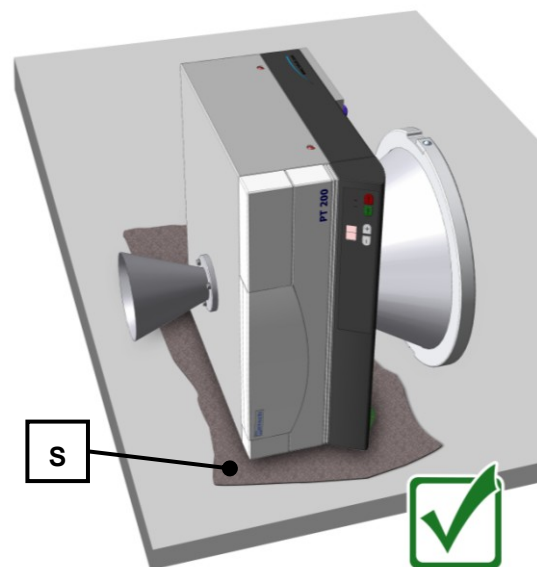

Fig. 6: Setting down the device for assembly

After unpacking set down the device on its side only and on a soft and clean surface (S).

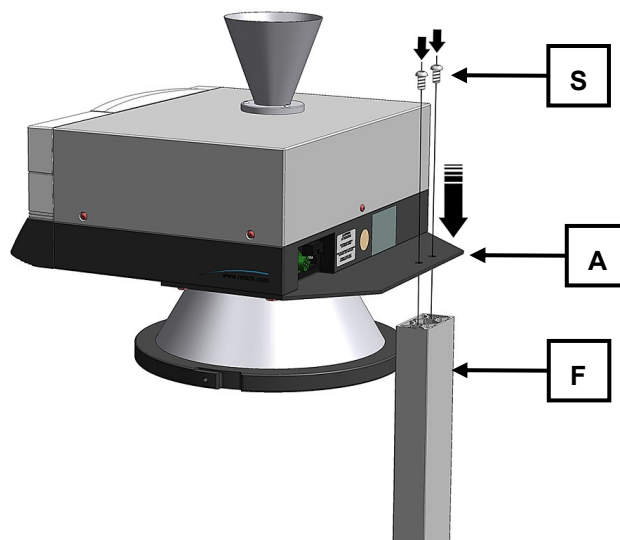

Fig. 7: Fitting the device to the base

Place the rear assembly area (A) of the bottom plate on the frame (F).

Tighten the two screws (S) by hand.

## 5.6 Switching On and Off

 **WARNING**

**Risk of a fatal electric shock**

- An electric shock can cause injuries in the form of burns and cardiac arrhythmia, respiratory arrest or cardiac arrest.
- **Do not clean the blender under running water. Use only a cloth dampened with water.**
- **Disconnect the power supply plug before cleaning the blender.**

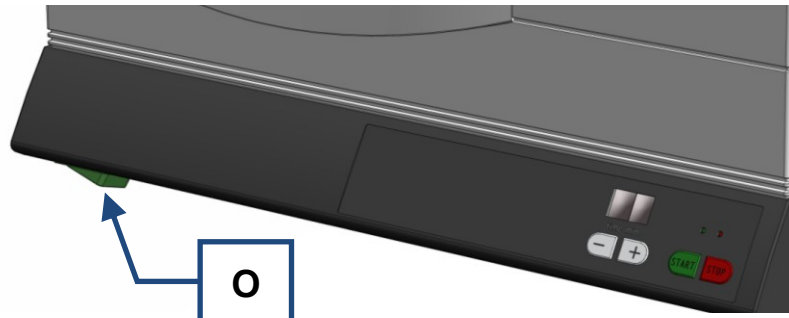

Fig. 8: On/off switch

The on/off switch (O) is located on the left side of the device below the operating element.

- Press the on/off switch (O).

**5.7 Inserting bottom cone**

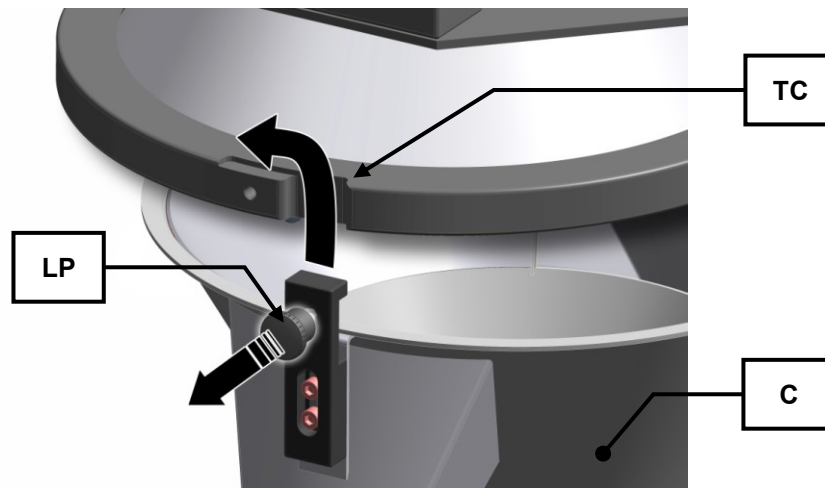

Fig. 9: Inserting the bottom cone

- Hold the two latch pins (LP) to insert the bottom cone (C).
- Pull out the two latch pins (LP) and insert the bottom cone into the holder of the top cone (TC).
- Turn the bottom cone in a clockwise direction until the two latch pins lock in.
- It may be necessary to move the bottom cone (C) a little after insertion so that the two latch pins can lock in.

**5.8 Inserting sample vessel**

 **CAUTION**

1.V0066

**Injuries from cuts and other injuries**

Hazard from splintered glass

- Sample beakers may fall down during use. Injuries from cuts may occur from splintered glass.
- **Ensure that the sample receptacles are correctly positioned in the holders.**
- **Replace any damaged sample beakers**
- **Do not touch splintered glass with hands.**

**NOTICE**

2.H0056

**Material loss**

- Sample material can be scattered in the surrounding area in the absence of sample receptacles.
- Ensure that all dividing tubes are equipped with sample receptacles.

**5.8.1 Inserting the sample container into the quick-release sample outlet**

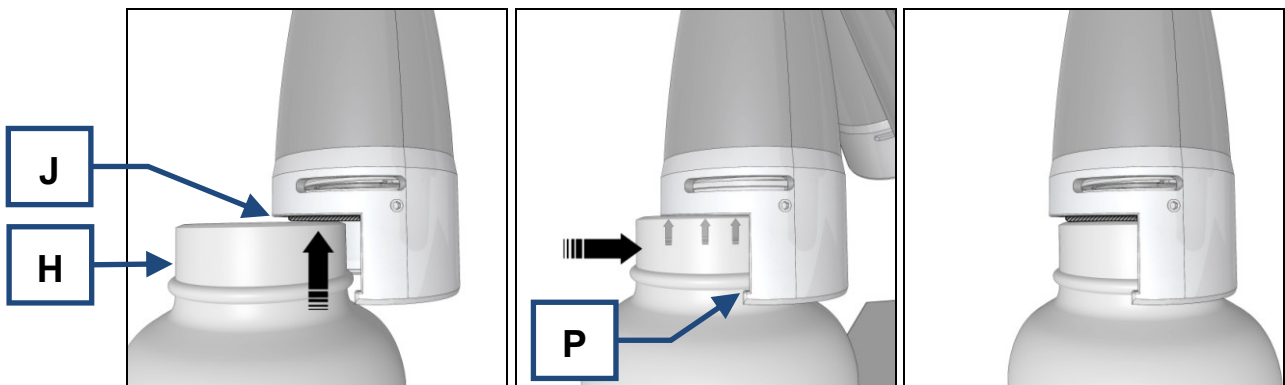

Fig. 4:

Fig. 5: Inserting the sample container (quick-release sample outlet)

- Position the sample container (H) in relation to the compression disk (J [shaded]).
- Press the compression disk (J) along with the sample container (H) upwards.
- Push the sample container backwards into the support (P) and lower it until it locks into place.

 **CAUTION**

**Danger of personal injury**

Dangerous nature of the sample

- Depending on the dangerous nature of your sample, take the necessary measures to rule out any danger to persons.
- **Observe the safety guidelines and datasheets of your**



sample material.

## 5.9 Starting, Interrupting, Stopping

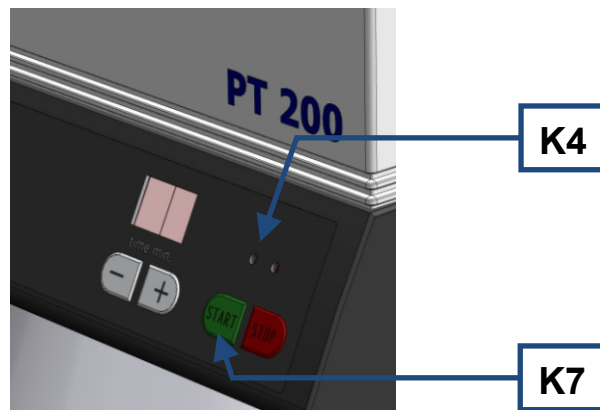

Fig. 10: Starting the device

- Press the START button (K7).
- The green LED (K4) above the START button (K7) lights up.
- The pre-set dividing time can be seen in the display.
- The dividing tube starts to turn.
- The remaining minutes of the division are shown in the display.
- At the end of the dividing time the remaining seconds are shown.

## 5.10 Process Run Duration



Fig. 11: Setting the throughput duration

- Set the duration of the sample throughput by pressing the buttons "time min."

You can choose the following time intervals:

(in minutes)

co (continuous) – 1 – 3 – 5 – 10 – 20 – 30 – 40 – 50 – 60

## 5.11 Attaching vibratory feeder



Fig 12: Assembly of the vibratory feeder

For sample division of larger volumes and as a condition for higher division accuracy, it is generally advisable to evenly feed in the sample material using a vibratory feeder. The Retsch vibratory feeder DR100 is a suitable accessory for this purpose.

- Position the vibratory feeder on the device.

A device socket is located on the back of the device.

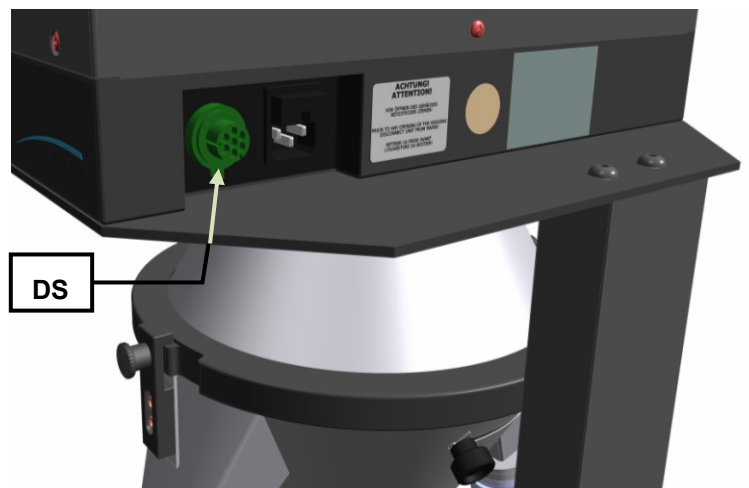

Fig. 13: Back of the device and interface

- Insert the mains cable of the DR100 into device socket on the back of the device (DS).

## 5.12 Creating interface connection

Before setting up the DR100, read the DR100 operating manual.

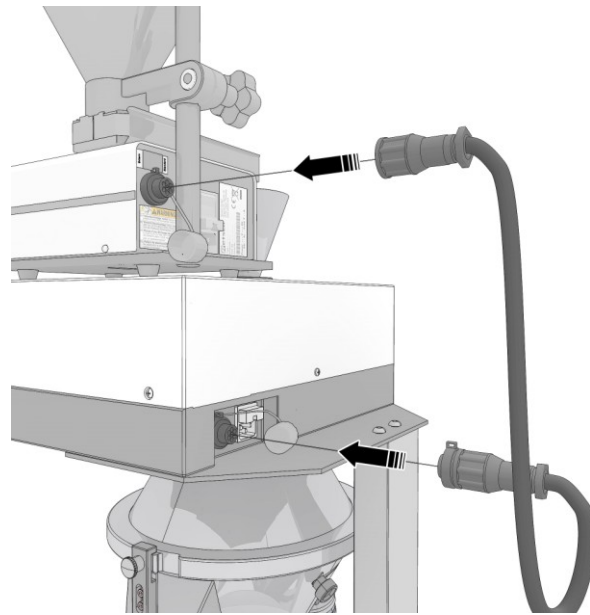

Fig. 14: Connecting the PT200 to the DR100

For the connection between the DR100 and the PT200, use the interface cable, which is included in the retrofit kit's scope of supply.

- Insert the connection cable (**VK**) into the interface (**DF**) on the back of the DR100.

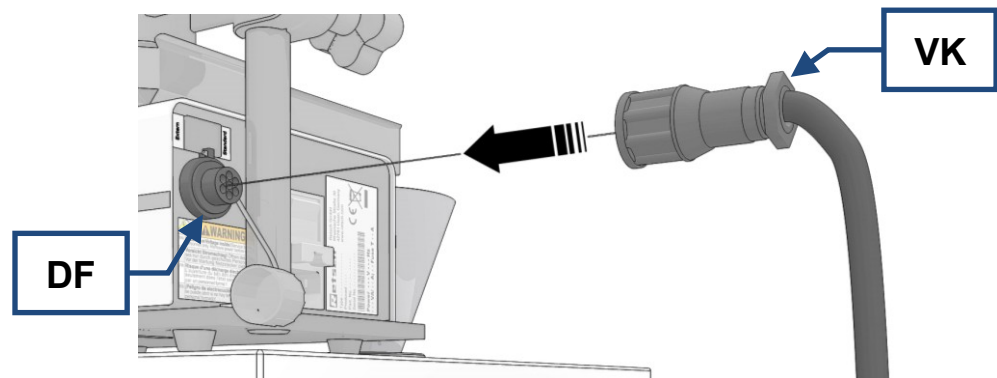

Fig. 2: DR100 – Insert the connection cable.

Insert the connection cable (**VK**) into the interface (**PF**) on the back of the PT200.

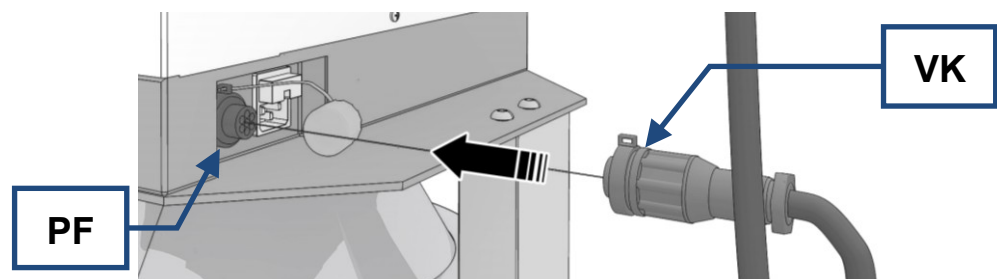

Fig. 3: PT200– Insert the connection cable

### 5.13 Starting device and vibratory device simultaneously

- Put sample vessels onto all sample outlets on the device.



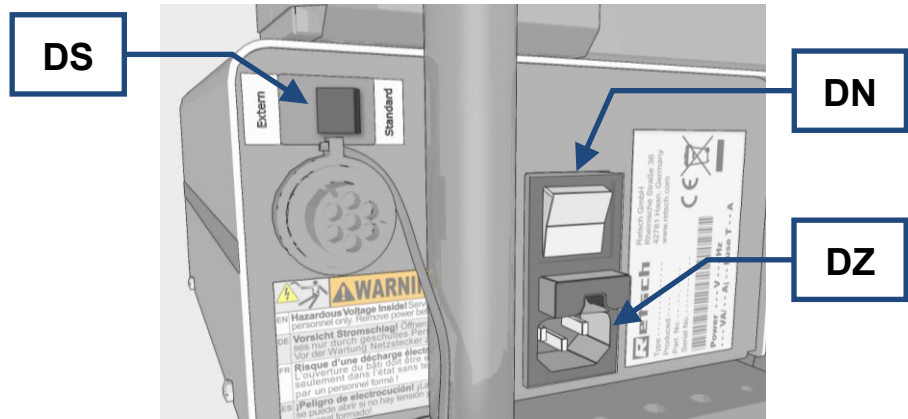

Fig. 15: Rear view of the DR100

**NOTE**

PT 100 and DR100 must be suitable for the same electrical mains supply, (see type plate).

Failure to comply with the ratings on the type plate on the PT 100 and DR100 can cause damage to electronic and mechanical components.

- Connect the DR100 to the mains power supply using the C13 panel-mounted male connector (inlet) **(DZ)**.
- Set the switch **(DS)** on the back of the DR100 to “Standard”.

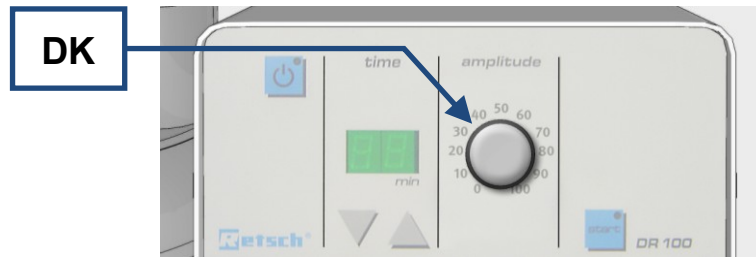

Fig. 5: Setting the DR100 feeding speed

- Set the feeding speed regulator **(DK)** on the DR100 to the required position (depending on the material to be divided).
- Fill the DR100 feed hopper.
- Adjust the slot width between the feed hopper outlet and the push-fit chute base (feed level).

The setting of the gap between the push-fit chute and the feed hopper depends on the maximum particle size of the feed material. It should be about 3 times as large as the max. particle size.

- Press the ON/OFF switch **(DN)** on the DR100 .
- Turn on the sample divider and start it.

The DR100 does not start until the sample divider has reached the nominal speed.

The DR100 switches off automatically when the nominal speed of the sample divider varies too much or drops. If this fluctuation lasts only for a short time (<5s), the DR100 switches on again once the nominal speed has been reached again and the feeding process is continued. As soon as you stop the sample divider, the DR100 stops too and the sample is not fed.

**5.14 Setting the sample slot width**

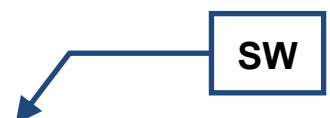

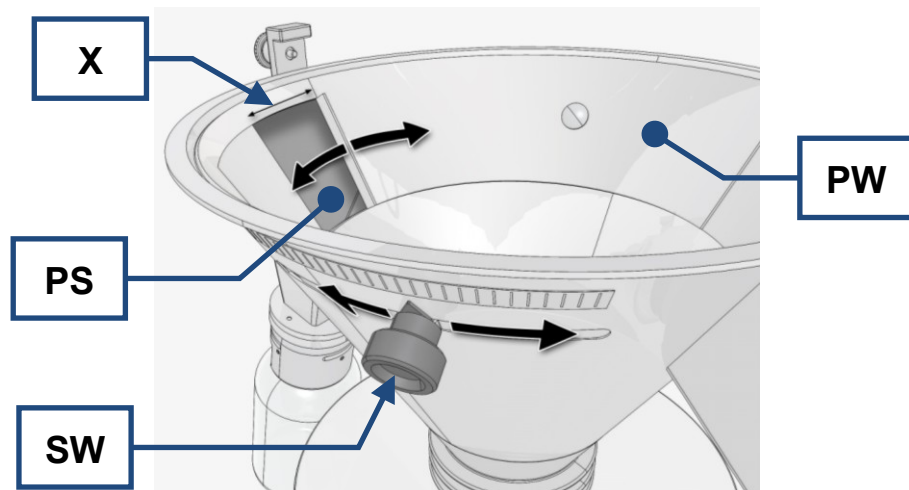

Fig. 6: Setting the opening width

The sub-sample is determined by the opening width of the sampling nozzle (**PS**). The maximum opening width(**PS**) in the standard bottom cone is 70 mm.

- Loosen the two knurled screws (**SW**).
- Set the opening width(**X**) by moving the slide (**PW**).

The scale on the bottom cone serves merely as an adjustment aid and does not indicate the actual opening width(**X**). The actual opening width(**X**) is measured in the centre of the slot.

- Once you have set the opening width, tighten the knurled screws again.

## 5.15 Calculating the slot width

### 5.15.1 Sample nozzle – Opening width

The calculation of the opening width (x) depends on the feed quantity( QA ) and the required fraction (QT) at a fixed pitch circumference ( UK ) of 795 mm.

#### Key to symbols

UK = fixed pitch circumference

QA = Initial quantity

QT = Fraction

X = Slot width

Example :

QA = 0.200 kg

QT = 0.010 kg

UK = 795 mm

Formula:

$$X = \frac{UK * QT}{QA}$$

$$X = \frac{795 * 10}{200}$$

X = 39.75 mm opening width

The accuracy of this calculation depends on the maximum particle size. The finer the feed quantity, the more precise the calculation.

Determine the minimum opening width.

The minimum opening width must correspond to at least three times the maximum particle size .

Example :

Particle size = 8 mm

Minimum opening width= 3 x 8 = 24 mm

Formula:

$$X_{\min} = 3 \times d_{\max}$$

If the opening width is narrower, a distortion of the sub-sample can be expected.

### 5.15.2 Determining the minimum opening width

The minimum opening width must correspond to at least three times the maximum particle size.

Example :

Particle size = 8 mm

Minimum opening width= 3 x 8 = 24 mm

Formula:

$$X_{\min} = 3 \times d_{\max}$$

If the opening width is narrower, a distortion of the sub-sample can be expected in this case.

### 5.16 Replacing the machine fuses

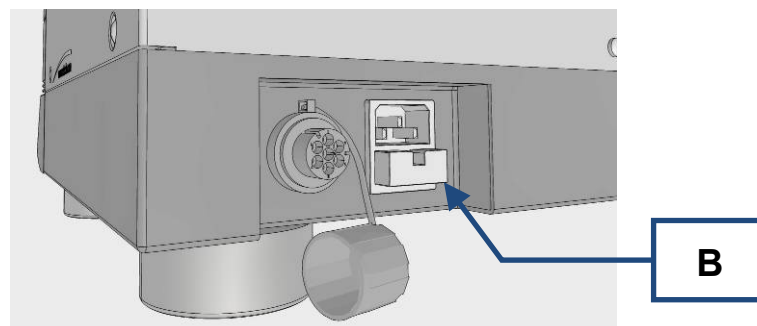

Fig. 16: Fuse holder

Fuses required:

2 glass fuses T 0.315 A (5x20mm)

- Pull the mains plug.
- Pull out the fuse holder (B).
- Replace the fuses.
- Insert the fuse holder.

The fuses in the inside of the device may only be replaced by Customer Service.

## 6 Cleaning and service

 **WARNING**

**Risk of a fatal electric shock**

- An electric shock can cause injuries in the form of burns and cardiac arrhythmia, respiratory arrest or cardiac arrest.
- **Do not clean the blender under running water. Use only a cloth dampened with water.**
- **Disconnect the power supply plug before cleaning the blender.**

*NOTICE*

3.H0006

**Defective components due to liquids**

Penetration of liquids into the inside of the device

- Components are damaged and the function of the device is no longer ensured.
- **Clean the device under running water. Only use a moist cloth**

*NOTICE*

**Damage to the machine through solvents**

- Solvents may damage plastic parts and the paint finish.
- **It is not allowed to use solvents.**

This device is designed such that all parts coming into contact with material may be removed easily and without tools.

These parts taken from the device can therefore also be cleaned in a water bath, under running water and in a dishwasher.

## 7 Fault messages

Error code	Error	Measure
F1	Motor doesn't start or is not running	Press the STOP button; if the error persists, after-sales service must be consulted
F3	Speed is too high or too low	Press the STOP button; after-sales service must be consulted if the error persists.
F5	Keypad defective	Service necessary

## 8 Disposal

Please observe the respective statutory requirements with respect to disposal.

Information on disposal of electrical and electronic machines in the European Community.

Within the European Community the disposal of electrically operated devices is regulated by national provisions that are based on the EU Directive 2002/96/EC on Waste Electrical and Electronic Equipment (WEEE).

Accordingly, all machines supplied after 13.08.2005 in the business-to-business area to which this product is classified, may no longer be disposed of with municipal or household waste. To document this they have the following label:

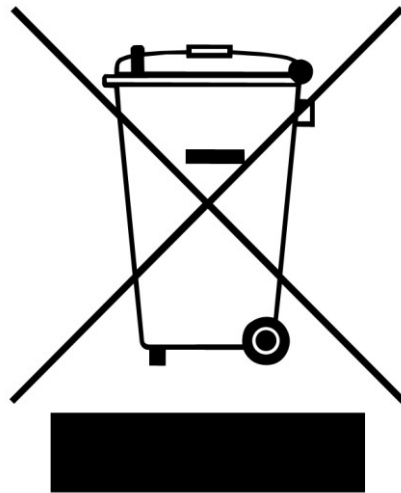

Fig. 17: Disposal label

Since the disposal regulations within the EU may differ from country to country we would request you to consult your supplier.

## 9 Index

<b>4</b>	
45635-31-01-KL3.....	12
<b>A</b>	
Accuracy.....	27
actual opening width.....	26
Amperage.....	11
attaching vibratory feeder.....	22
<b>B</b>	
Back of the device.....	16
Bar code.....	11
<b>C</b>	
calculating slot width.....	26
calculating slot width.....	26
Calculation.....	27
Capacity.....	11
CE marking.....	11
Changes.....	5
Cleaning and service.....	28
Conditions for the place of installation.....	10
Confirmation.....	9
Connection cable.....	11
Copyright.....	5
creating interface connection.....	23
<b>D</b>	
dB(A).....	12
Degree of protection.....	12
description.....	18
Description.....	16
Device designation.....	11
dimensions.....	13
Dimensions and weight.....	13
DIN 45635-31-01-KL3.....	12
disperse.....	12
Disposal.....	29
Disposal label.....	11
Disposal label.....	29
Drive output.....	12
<b>E</b>	
Electrical connection.....	11
emission value with regard to workplace.....	12
Emissions.....	12
Error.....	28
Error code.....	28
Explanations of the safety warnings.....	6
External fuse.....	11
<b>F</b>	
F1.....	28
F3.....	28
F5.....	28
Fault messages.....	28
feed size.....	13
feed size.....	12
Formula.....	26
fraction.....	12
function.....	18
Function.....	16
Fuse holder.....	27
Fuse strength.....	11
Fuse type.....	11
<b>G</b>	
General safety instructions.....	7
Gestell.....	18
glass fuses.....	27
<b>I</b>	
inserting bottom cone.....	20
Inserting sample vessel.....	20
installation.....	12
Installation height.....	10
Installation of the machine.....	10

<b>L</b>		<b>R</b>	
LpAeq.....	12	Rated power.....	12
<b>M</b>		Receptacle volume .....	13
Mains frequency .....	11	Regulations for the place of installation .....	11
Manufacturer's address .....	11	Repairs.....	8
maximum opening width .....	26	Replacing the machine fuses.....	27
min <sup>-1</sup> .....	12	Required floor space.....	14
minimum opening width .....	27	revolutions.....	12
Moderate or mild injury .....	6	Rotation speed.....	12
Montage des Untergestells.....	18	rpm.....	12
<b>N</b>		<b>S</b>	
noise details.....	12	Safety warnings .....	6
noise values.....	12	Sample nozzle .....	26
Notes on the Operating Manual.....	5	Sampling nozzle.....	26
Number of fuses .....	11	Serial number.....	11
<b>O</b>		serious injury.....	6
On/off switch .....	16	Service Address.....	8
Opening width.....	26	setting the sample slot width.....	25
Opening width.....	26	Slot width .....	26
Operating elements and displays .....	18	sound power level.....	12
Operating the machine .....	14	Standard bottom cone.....	26
Overview Table of the Operating Elements and the Display .....	18	starting device and vibratory device simultaneously .....	24
Overview table of the parts of the device .....	16	Starting, Interrupting, Stopping .....	22
<b>P</b>		stepping motor .....	12
Packaging .....	10	Switching On and Off.....	19
Part number .....	11	SWL .....	12
Particle size .....	27	<b>T</b>	
Pitch circumference .....	26	Target group .....	7
pourable.....	12	Technical data.....	11
Power version .....	11	Temperature fluctuation and condensed water .	10
preparation systems .....	12	Transport.....	10
Process Run Duration.....	22	Transport, scope of delivery, installation .....	10
property damage.....	6	Type plate .....	11
<b>Q</b>		type plate description .....	10
Quick-release sample outlet.....	21	Type plate lettering .....	11
		<b>U</b>	
		Untergestell.....	18

Use of the machine for the intended purpose .... 12

**V**

View of the control panel ..... 16

View of the device..... 15

Views of the Instrument ..... 14

**W**

watt..... 13

**Y**

Year of production..... 11



# LABORATORY SAMPLE DIVIDER PT200

Certificate of CE-Conformity according to:

**EC Mechanical Engineering Directive 2006/42/EC**

Applied harmonized standards, in particular:

DIN EN ISO 12100                      Security of machines

**EC Directive Electromagnetic Compatibility 2004/108/EC**

Applied standards, in particular:

DIN EN 55011	Emission
DIN EN 61000-3-2    DIN EN 61000-3-3	Emission
DIN EN 61326-1    DIN EN 61000-6-2	Immunity

**Additional applied standards, in particular**

DIN EN 61010-1              Safety prescriptions concerning measuring-, operating-, controlling- and laboratory equipment

DIN EN 60950-1              Information technology equipment – Safety

**Authorized person for the compilation of technical documents:**

J. Bunke (technical documentation)

**The following records are held by Retsch GmbH in the form of Technical Documentation:**

Detailed records of engineering development, construction plans, study (analysis) of the measures required for conformity assurance, analysis of the residual risks involved and operating instructions in due form according to the approved regulations for preparation of user information data.

The CE-conformity of the Retsch Laboratory Sample Divider PT200 is assured herewith.

**In case of a modification to the machine not previously agreed with us as well as the use of not licensed spare parts and accessories this certificate will lose its validity.**

Retsch GmbH

Haan, October 2011

Dr.-Ing. Frank Janetta  
Manager Development









**Copyright**

® Copyright by  
Retsch GmbH  
Haan, Retsch-Allee 1-5  
D-42781 Haan  
Federal Republic of Germany