

Manual Mixer Mill CryoMill



Translation



Copyright

© Copyright by
Retsch GmbH
Haan, Retsch-Allee 1-5
D-42781 Haan
Federal Republic of Germany

1	Notes on the Operating Manual	6
1.1	Explanations of the safety warnings	7
1.2	General safety instructions	8
1.3	Repairs	9
2	Confirmation	10
3	Technical data	11
3.1	Protective equipment	11
3.2	Emissions	11
3.3	Degree of protection	12
3.4	Rated power	12
3.5	Dimensions and weight	12
3.6	Required floor space	12
4	Transport, scope of delivery, installation	13
4.1	Packaging	13
4.2	Transport	13
4.3	Temperature fluctuations and condensed water	13
4.4	Conditions for the place of installation	13
4.5	Installation of the machine	14
4.6	Removing the transport safeguard	14
4.7	Type plate description	18
4.8	Electrical connection	19
4.9	Connecting the cooling agent feed	19
4.10	Removing the liquid nitrogen feed line	23
4.11	Cold air outlet	24
4.12	Mounting the exhaust hose	24
5	Operating the machine	26
5.1	Use of the machine for the intended purpose	26
5.2	Operating elements and displays	27
5.3	Summary table of device parts	28
5.4	Operating elements and displays	29
5.5	Inserting the grinding jar	31
5.5.1	Inserting and removing CryoMill special grinding jar	31
5.5.2	Inserting the cooling jacket sealing plug	34
5.5.3	Insert the adapter for 4/2 x 5 ml grinding jar	35
5.5.4	Insert the adapter for 6 / 4 / 2 x 2-ml Eppendorf reaction vial	36
5.6	Explanations of the grinding cycles	37
5.6.1	Grinding without cooling	37
5.6.2	Grinding with cooling	37

5.7	Programs	38
5.7.1	Grinding without program	38
5.7.2	Grinding with program	39
5.7.2.1	Selection of a program.....	39
5.7.2.2	Display of the program grinding parameters	39
5.7.2.3	Create/change a program.....	39
5.7.2.4	Delete program	40
5.8	Setting grinding cycles.....	40
5.9	Setting the precooling time	41
5.9.1	Precooling with definable precooling time	41
5.9.2	Automatic precooling	41
5.10	Setting the grinding time	42
5.11	Setting the duration of intermediate cooling	42
5.12	Setting the grinding frequency	43
5.13	Starting the grinding process	43
5.14	Interrupting and continuing the grinding process	44
5.14.1	Pausing grinding	44
5.14.2	Cancelling grinding	44
5.15	Stopping the grinding process	44
5.16	Operating hours display.....	45
5.17	Operating software display	46
5.18	Replacing the machine fuses.....	46
6	Working instructions.....	48
6.1	General	48
6.2	The grinding process	48
6.3	Quantities of sample material and feed sizes.....	48
6.4	Working instructions	49
7	Safety functions and fault display	50
7.1	Fault messages	50
8	Cleaning, wear and service	51
8.1	Cleaning.....	51
8.2	Wear	51
8.3	Wearing parts	51
8.4	Service.....	51
8.5	Checks.....	52
9	Safety and occupational health instructions.....	52
9.1	General	52
9.2	Safety instructions on the handling of liquid nitrogen	54
9.3	Oxygen deficiency	54

9.3.1	Dangers	54
9.3.2	Causes.....	54
9.3.3	Recommendations	54
9.3.4	General conduct in the case of an accident	55
9.4	Cryogenic burns.....	55
9.4.1	Dangers	55
9.4.2	Causes.....	55
9.4.2.1	Burns through splashes	55
9.4.2.2	Burns through contact.....	56
9.4.3	Recommendations	56
9.4.4	General rules of conduct for splashes with liquid nitrogen	56
9.4.4.1	To the eyes	56
9.4.4.2	On the skin.....	56
9.5	Danger of explosion.....	56
9.5.1	Dangers	56
9.5.2	Causes.....	56
9.5.3	Recommendations	57
9.5.4	General conduct in the case of an accident	57
9.6	Oxygen enrichment.....	57
9.6.1	Dangers	57
9.6.2	Causes.....	57
9.6.3	Recommendations	57
9.7	Surrounding area of the machine	58
9.7.1	Rooms.....	58
10	Disposal.....	59
11	Index	60
Appendix following pages	

1 Notes on the Operating Manual

This operating manual is a technical guide on how to operate the device safely and it contains all the information required for the areas specified in the table of contents. This technical documentation is a reference and instruction manual. The individual chapters are complete in themselves.

Familiarity (of the respective target groups defined according to area) with the relevant chapters is a precondition for the safe and appropriate use of the device.

This operating manual does not contain any repair instructions. If faults arise or repairs are necessary, please contact your supplier or get in touch with Retsch GmbH directly.

Application technology information relating to samples to be processed is not included but can be read on the Internet on the respective device's page at www.retsch.com.

Changes

Subject to technical changes.

Copyright

Disclosure or reproduction of this documentation, use and disclosure of its contents are only permitted with the express permission of Retsch GmbH.

Infringements will result in damage compensation liability.

1.1 Explanations of the safety warnings

In this Operating Manual we give you the following safety warnings

Serious injury may result from failing to heed these safety warnings. We give you the following warnings and corresponding content.

 **WARNING**

Type of danger / personal injury

Source of danger

- Possible consequences if the dangers are not observed.
- **Instructions on how the dangers are to be avoided.**

We also use the following signal word box in the text or in the instructions on action to be taken:

 **WARNING**

Moderate or mild injury may result from failing to heed these safety warnings. We give you the following warnings and corresponding content.

 **CAUTION**

Type of danger / personal injury

Source of danger

- Possible consequences if the dangers are not observed.
- **Instructions on how the dangers are to be avoided.**

We also use the following signal word box in the text or in the instructions on action to be taken:

 **CAUTION**

In the event of possible **property damage** we inform you with the word “Instructions” and the corresponding content.

NOTICE

Nature of the property damage

Source of property damage

- Possible consequences if the instructions are not observed.
- **Instructions on how the dangers are to be avoided.**

We also use the following signal word in the text or in the instructions on action to be taken:

NOTICE

1.2 General safety instructions

 **CAUTION**

Read the Operating Manual

Non-observance of these operating instructions

- The non-observance of these operating instructions can result in personal injuries.
- **Read the operating manual before using the device.**
- **We use the adjacent symbol to draw attention to the necessity of knowing the contents of this operating manual.**



Target group : All persons concerned with the machine in any form

This machine is a modern, high performance product from Retsch GmbH and complies with the state of the art. Operational safety is given if the machine is handled for the intended purpose and attention is given to this technical documentation.

You, as the owner/managing operator of the machine, must ensure that the people entrusted with working on the machine:

- have noted and understood all the regulations regarding safety,
- are familiar before starting work with all the operating instructions and specifications for the target group relevant for them,
- have easy access always to the technical documentation for this machine,
- and that new personnel before starting work on the machine are familiarised with the safe handling of the machine and its use for its intended purpose, either by verbal instructions from a competent person and/or by means of this technical documentation.

Improper operation can result in personal injuries and material damage. You are responsible for your own safety and that of your employees.

Make sure that no unauthorised person has access to the machine.

 **CAUTION**

Changes to the machine

- Changes to the machine may lead to personal injury.
- **Do not make any change to the machine and use spare parts and accessories that have been approved by Retsch exclusively.**

NOTICE

Changes to the machine

- The conformity declared by Retsch with the European Directives will lose its validity.
 - You lose all warranty claims.
 - **Do not make any change to the machine and use spare parts and accessories that have been approved by Retsch exclusively.**
-

1.3 Repairs

This operating manual does not contain any repair instructions. For your own safety, repairs may only be carried out by Retsch GmbH or an authorized representative or by Retsch service engineers.

In that case please inform:

The Retsch representative in your country
Your supplier
Retsch GmbH directly

Your Service Address:

2 Confirmation

This operating manual contains essential instructions for operating and maintaining the device which must be strictly observed. It is essential that they be read by the operator and by the qualified staff responsible for the device before the device is commissioned. This operating manual must be available and accessible at the place of use at all times.

The user of the device herewith confirms to the managing operator (owner) that (s)he has received sufficient instructions about the operation and maintenance of the system. The user has received the operating manual, has read and taken note of its contents and consequently has all the information required for safe operation and is sufficiently familiar with the device.

As the owner/managing operator you should for your own protection have your employees confirm that they have received the instructions about the operation of the machine.

I have read and taken note of the contents of all chapters in this operating manual as well as all safety instructions and warnings.

User

Surname, first name (block letters)

Position in the company

Signature

Service technician or operator

Surname, first name (block letters)

Position in the company

Place, date and signature

3 Technical data

3.1 Protective equipment

The grinding chamber of the CryoMill laboratory mill is surrounded by a stable hood.

It is only possible to start the device when the hood is closed.

3.2 Emissions

Noise values:

The noise values are also influenced by the properties of the sample material.

No-load operation:

Emission value with regard to workplace L_{pAeq} = 61,4 dB(A)

Example 1:

Emission value with regard to workplace L_{pAeq} = 75,2 dB(A)

Operating conditions:

Receptacle:	1 50ml steel grinding jar
Grinding component:	1 25mm steel ball each
Feed material:	Quartz gravel particles approx. 4.0 – 6.0mm
Feed quantity:	8ml
Frequency:	30 Hz

Example 2:

Emission value with regard to workplace L_{pAeq} = 66,3 dB(A)

Operating conditions:

Receptacle:	4 5ml steel grinding jar
Grinding component:	2 8mm tungsten carbide balls each
Feed material:	Quartz gravel particles approx. 1.0 – 1.5mm
Feed quantity:	1.5ml
Frequency:	30 Hz

 **CAUTION**

Hearing loss

A high sound level may occur depending on the type of material, the number of balls used, the set grinding frequency and the grinding time.

- Excess noise in terms of intensity and duration can lead to impairments or permanent damage to hearing.
- **Ensure you take suitable soundproofing measures or wear hearing protection.**



3.3 Degree of protection

IP30

3.4 Rated power

260 watts

3.5 Dimensions and weight

Height : 370 to approx. 630 mm with open hood

Width: 385 mm

Depth: 570 mm

Weight: approx. 46 kg without grinding jar

3.6 Required floor space

Supporting surface: 500 mm x 650 mm

4 Transport, scope of delivery, installation

4.1 Packaging

The packaging is designed for the transport route. It corresponds to generally acceptable packaging guidelines.

NOTICE

Storage of packaging

- In the event of a complaint or return, your warranty claims may be endangered if the packaging is inadequate or the machine has not been secured correctly.
 - **Please keep the packaging for the duration of the warranty period.**
-

4.2 Transport

NOTICE

Transport

- Mechanical or electronic components may be damaged.
 - **The machine may not be knocked, shaken or thrown during transport.**
-

4.3 Temperature fluctuations and condensed water

NOTICE

Temperature fluctuations

The machine may be subject to strong temperature fluctuations during transport (e.g. aircraft transport)

- The resultant condensed water may damage electronic components.
 - **Protect the machine from condensed water.**
-

4.4 Conditions for the place of installation

NOTICE

Ambient temperature

- Electronic and mechanical components may be damaged and the performance data alter to an unknown extent.
 - **Do not exceed or fall below the permitted temperature range of the machine (5°C to 40°C / ambient temperature).**
-

Atmospheric humidity:

Maximum relative humidity 80% at temperatures up to 31°C, decreasing linearly up to 50% relative humidity at 40°C

NOTICE

Atmospheric humidity

- Electronic and mechanical components may be damaged and the performance data alter to an unknown extent.
 - **Do not exceed the admissible range for atmospheric humidity.**
-

4.5 Installation of the machine

Installation height: maximum 2000 m above sea level

NOTICE

Property damage

A very cold vapour plume escapes from the nitrogen gas outlet.

- The vapour plume can greatly cool objects. This is why the humidity in the air condenses.
 - **The area above the nitrogen gas outlet (B) up to the ceiling must be kept free.**
-

NOTE

Installation

- Depending on the operating status of the mill, there may be slight vibrations.
 - **Place the mill on an even, flat and balanced supporting surface only. The supporting surface must be stable and must not vibrate.**
-

NOTICE

Installation of the machine

- It must be possible to disconnect the machine from the mains at any time.
 - **Install the machine such that the connection for the mains cable is easily accessible.**
-

4.6 Removing the transport safeguard

NOTICE

Transport safeguard

- Components may be damaged.
 - **Operate the machine only without the transport safeguard or transport the machine only with transport safeguard.**
-
- Place the device on a stable table.
 - Pull the device carefully beyond the edge of the table in order to be able to reach the screw (TA).

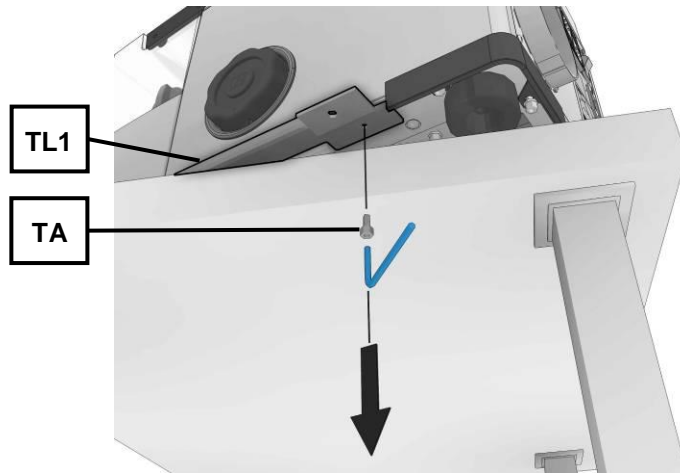

Fig. 1: Removing the transport bracket

- Remove the screw (TA) using an Allen key.

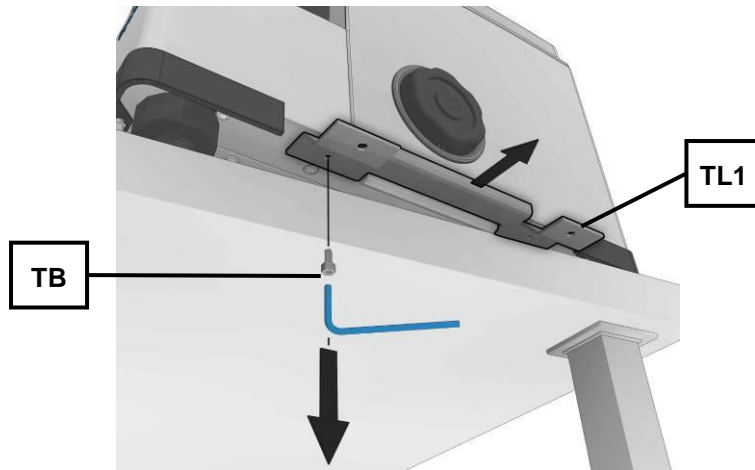

Fig. 2:

- Pull the device into the position shown in order to be able to remove the screw (TB).
- Remove the second screw (TB) and remove the transport bracket (TL1).

NOTICE

Keep the transport brackets, screws and transport lock for future transport!

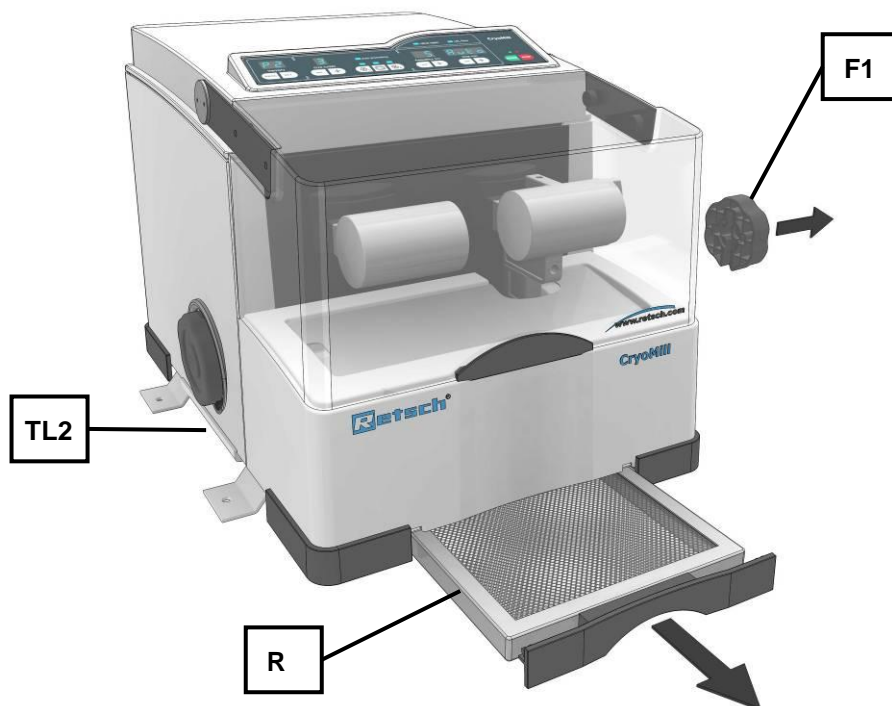

Fig. 3: Pulling out the condensation collecting filter

- Pull the condensation collecting filter (R) completely out of the device.
- Remove the opening aids (F1) on the side on which you have removed the transport bracket (TL1).
- Place a soft, clean mat (U) next to the device.
- Tilt the device onto the side on which the transport bracket (TL1) has been removed.

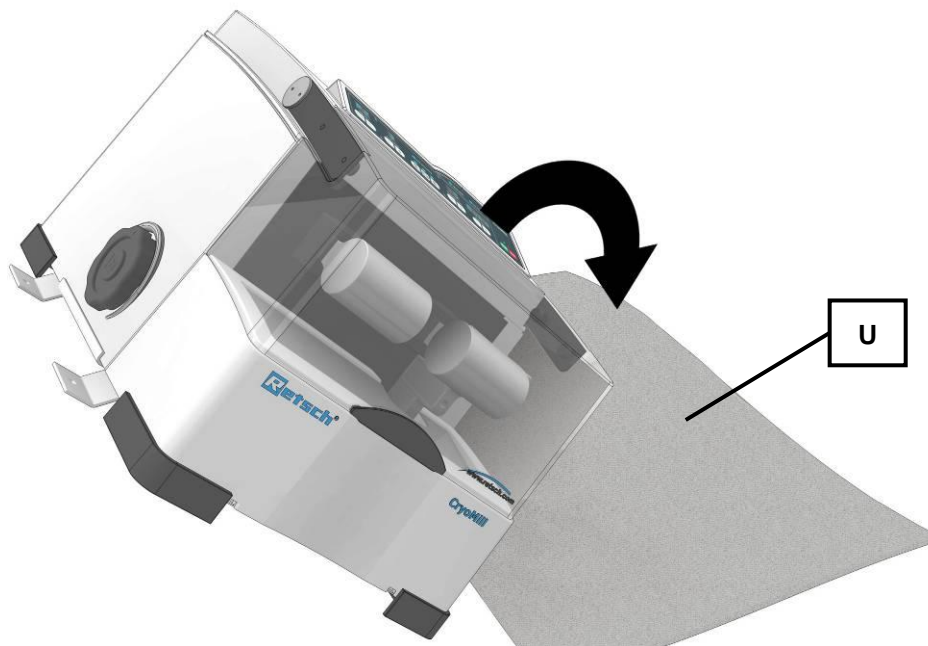

Fig. 4: Tilting the device onto its side

The transport lock (**TS**), which is labelled with an arrow, is situated on the underneath of the device.

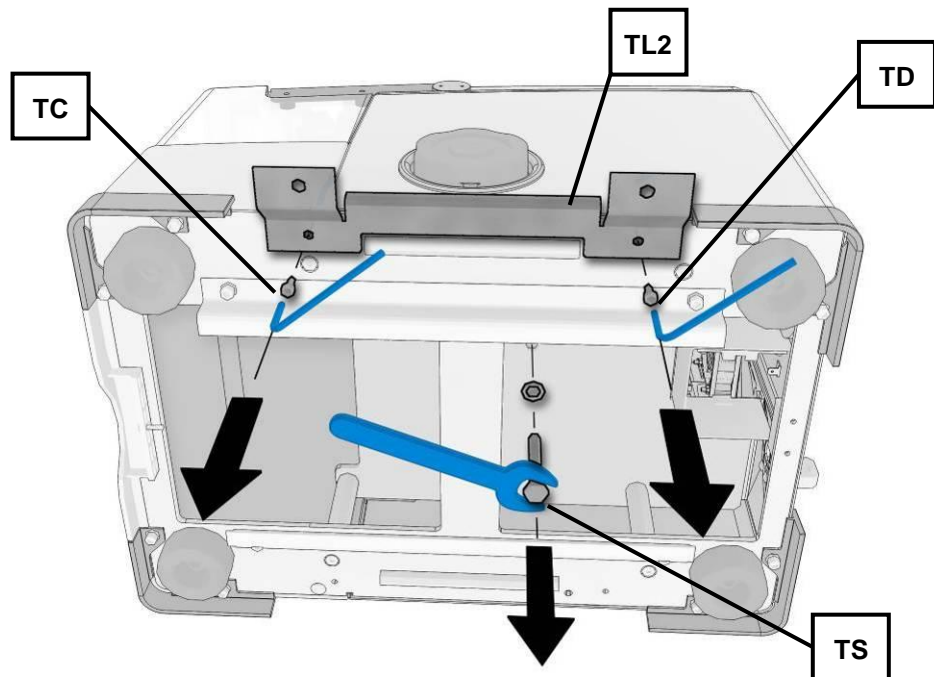

Fig. 5: Removing the transport lock

- Loosen and remove the screw (**TS**).
- Unscrew the two screws (**TC**) and (**TD**).
- Remove the transport bracket (**TL2**).

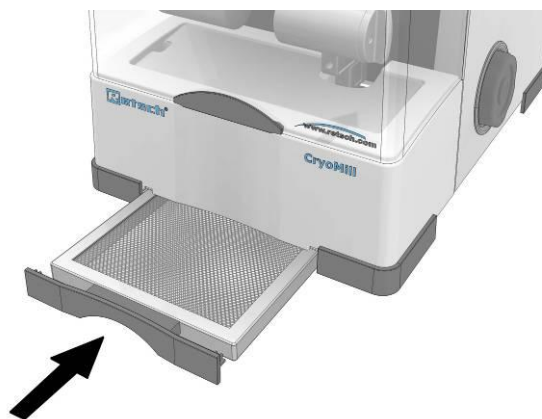

Fig. 6:

- Re-insert the condensation collecting filter (**R**).

NOTICE

Keep the transport brackets, screws and transport lock for future transport!

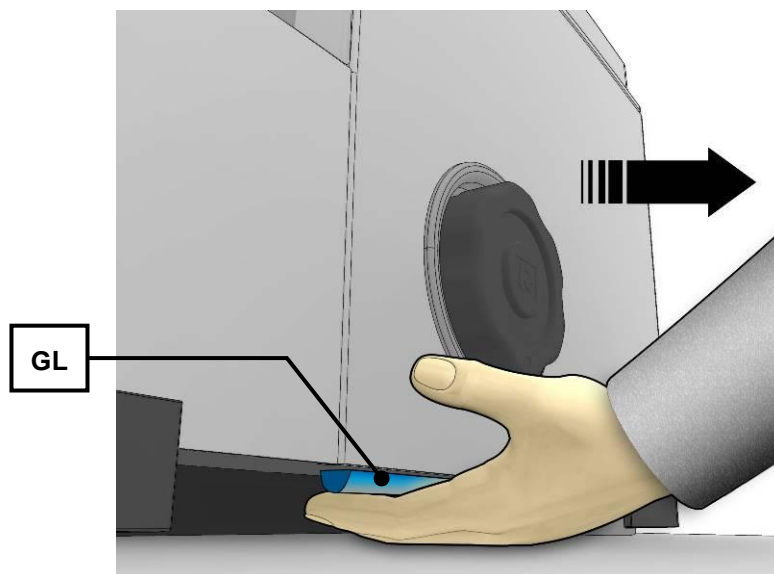

Fig. 7: Grip

A grip (**GL**) is situated underneath both sides of the device

- Use the grip (**GL**) to move the device.

4.7 Type plate description

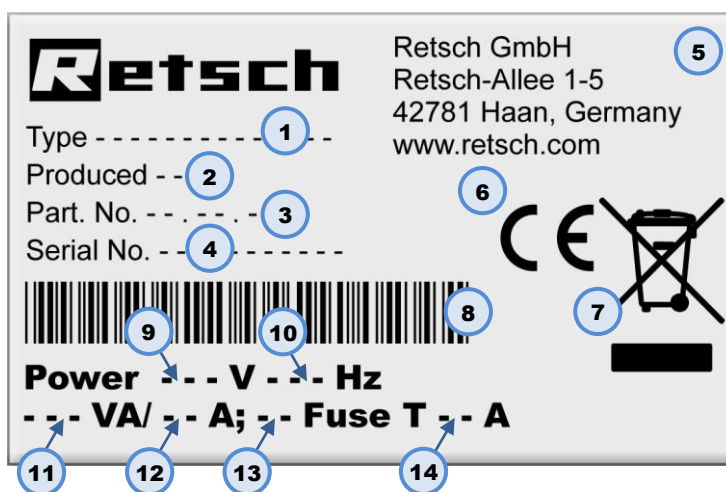

Fig. 8: Type plate lettering

- 1 Device designation
- 2 Year of production
- 3 Part number
- 4 Serial number
- 5 Manufacturer's address
- 6 CE marking
- 7 Disposal label
- 8 Bar code
- 9 Power version
- 10 Mains frequency

- 11 Capacity
- 12 Amperage
- 13 Number of fuses
- 14 Fuse type and fuse strength

In the case of questions please provide the device designation (1) or the part number (3) and the serial number (4) of the device.

4.8 Electrical connection

WARNING

When connecting the power cable to the mains supply, use an external fuse that complies with the regulations applicable to the place of installation .

- Please check the type plate for details on the necessary voltage and frequency for the device.
- Make sure the levels agree with the existing mains power supply.
- Use the supplied connection cable to connect the device to the mains power supply.

The external fuse must be at least T6.3A (230V) T8A (100/120V).

WARNING

Risk of a fatal electric shock

- An electric shock can cause injuries in the form of burns and cardiac arrhythmia, respiratory arrest or cardiac arrest.
 - **Do not clean the blender under running water. Use only a cloth dampened with water.**
 - **Disconnect the power supply plug before cleaning the blender.**
-

NOTICE

Electrical connection

- Mechanical or electronic components may be damaged.
 - **Please observe the information on the type plate.**
-

4.9 Connecting the cooling agent feed

 **CAUTION**

Blocked pipe

Ice formation

- Ice or impurities can block pipes and thereby cause malfunctions.
- **Keep the cooling system and supply pipe dry and free from impurities.**
- **Do not insert the grinding jar if it is damp or covered with frost.**
- **Insert the cooling jacket seal (KA) if you will not be using the device for a long period.**
- **Do not operate the device unattended.**

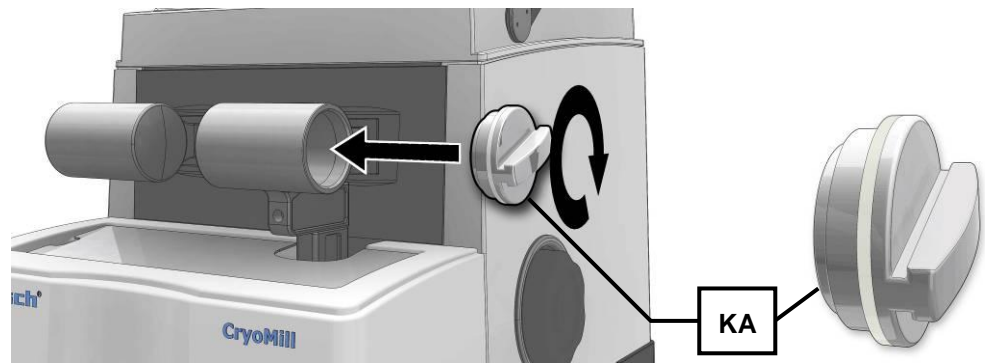

Fig. 9: Cooling jacket seal

NOTICE

Damage to the machine

Incorrect cooling agent

- The use of cooling agents other than liquid nitrogen will cause the cooling system to lose its leak tightness.
- **Only liquid nitrogen (LN2) may be used as cooling agent with this device.**

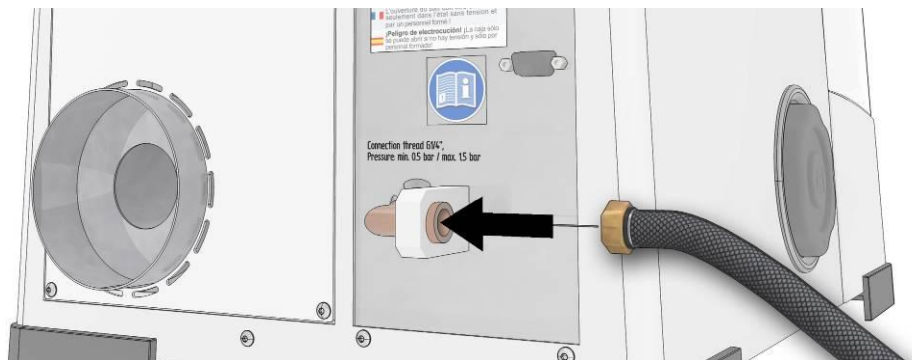

Fig. 10: Connecting the cooling agent supply

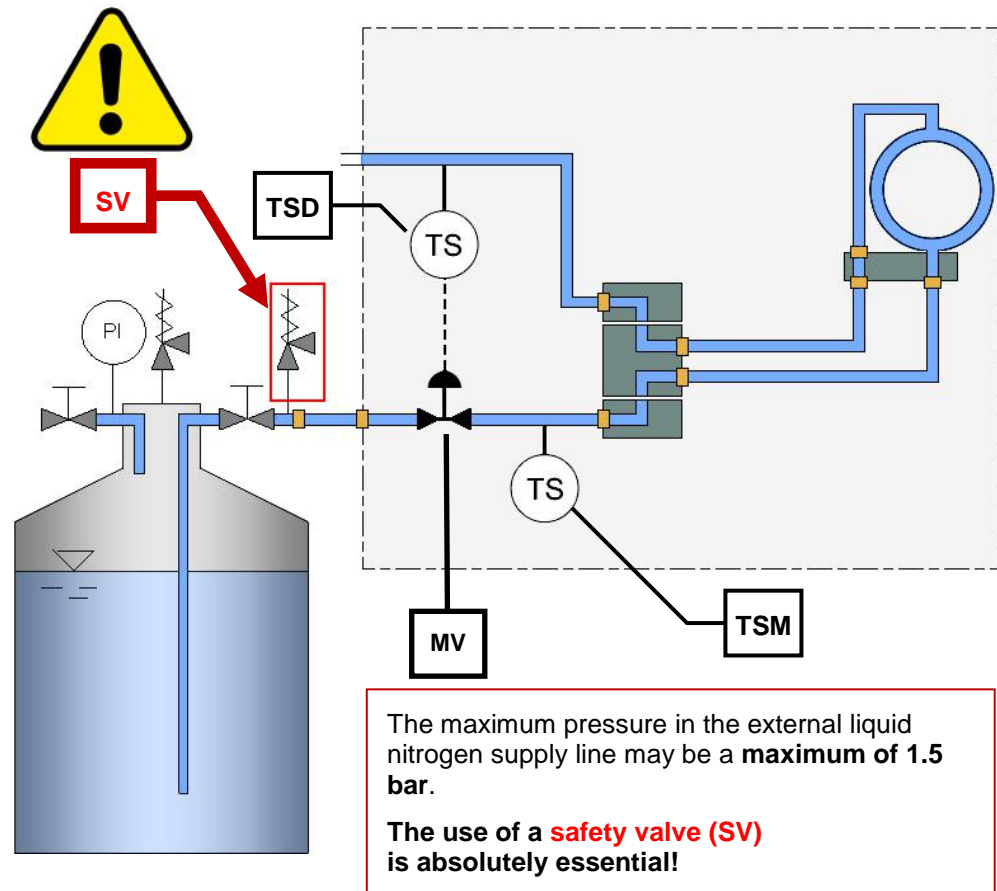

Fig. 11: Diagram of the cooling system

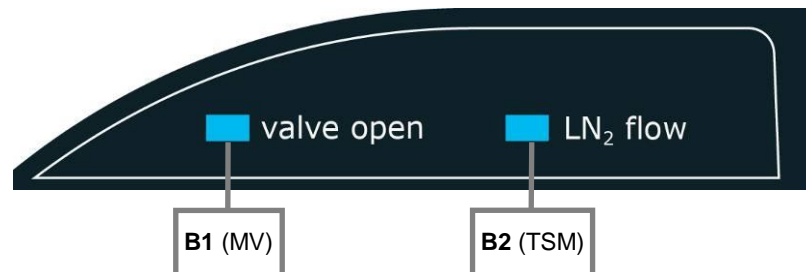

Fig. 12: LED displays

The temperature sensor (TSD) in the LN₂ outlet controls the solenoid valve (MV). The LED (B1) lights up when the solenoid valve (MV) is open.

The temperature sensor (TSM), which is downstream of the solenoid valve, registers whether liquid nitrogen is flowing into the CryoMill. The LED (B2) lights up when liquid nitrogen flows into the cooling system.

CAUTION

The device must not be moved in a cryogenic state and no additional forces may act on the cooling agent connection (N). The cooling agent inlet hose must not be moved while the device is in a cryogenic state.

⚠ CAUTION

Risk of injury and danger of frostbite

Bursting of the inlet hose.

- Depending on the operating state of the device, liquid nitrogen may be enclosed in the supply line. When heated this may lead to the inlet hose bursting.
- **The maximum pressure in the external liquid nitrogen supply line may be a maximum of 1.5 bar. The use of a safety valve is absolutely essential!**

The connection for the liquid nitrogen (LN₂) is a G 1/4 inch threaded connector .

The operating pressure in the liquid nitrogen supply line should be at least 0.5 bar. The lower the pressure of the liquid nitrogen supply line, the longer the precooling takes. At 0.5 bar supply line pressure and with the system at room temperature, precooling requires approx. 10 minutes. Depending on the application, you can execute up to 4 grinding operations with 10 litres of liquid nitrogen.

Throughout the entire duration of cooling, the air humidity in the chamber condenses on all cooled parts as a layer of ice .

After cooling this condensation drips into the collecting filter and evaporates.

⚠ CAUTION

Risk of injury and danger of frostbite

Uncontrolled escape of liquid nitrogen

- There is a risk of injury in the event of an uncontrolled escape of liquid nitrogen.
- **Stop the liquid nitrogen supply line immediately!**

NOTICE

Depending on the ambient temperature, air humidity and duration of use, small quantities of water may drip from the collecting filter.

4.10 Removing the liquid nitrogen feed line



Abb. 13: Removing the liquid nitrogen feed line

⚠ CAUTION

Before you remove the liquid nitrogen feed line, the pressure must be relieved for safety reasons.

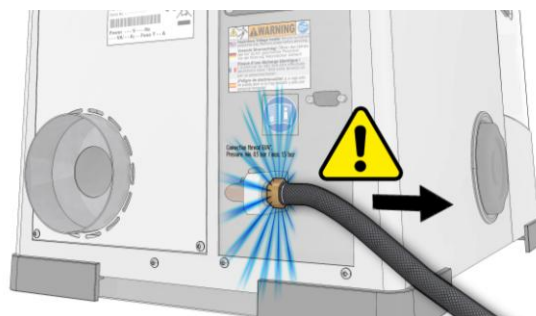

Abb. 14: pressure relief

- Press the **(B10)** pre-cooling and **(B13)** START keys simultaneously for 2 seconds.

As long as you keep the keys depressed, the solenoid valve will remain open.

4.11 Cold air outlet

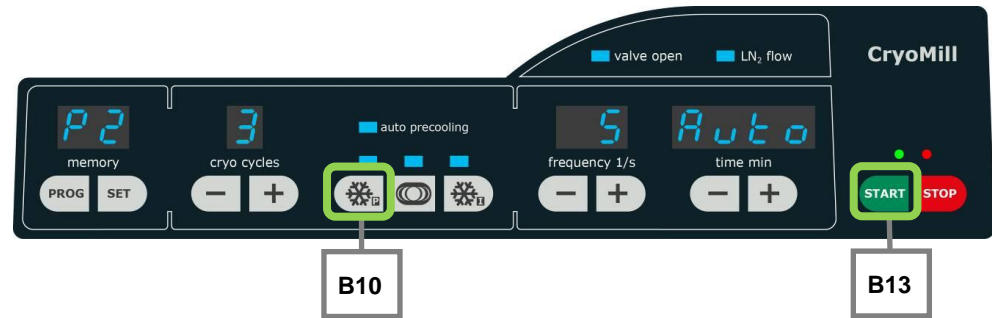
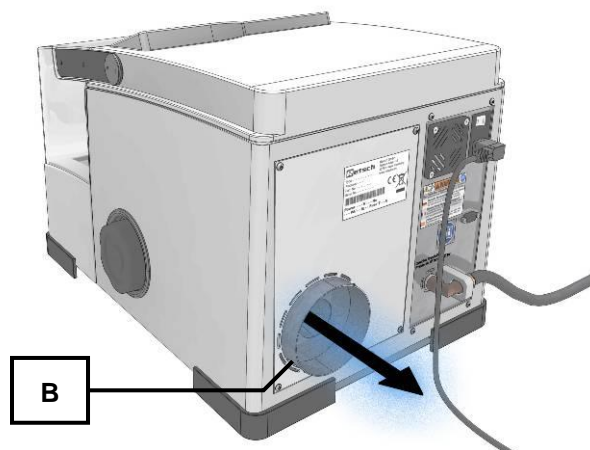

Fig. 15: Outlet for gaseous nitrogen (B)

CAUTION

Risk of injury to eyes and skin

Outlet for gaseous nitrogen

- Liquid nitrogen has a temperature of -196 °C and can cause burn-like injuries or frostbite in the case of contact with the skin or eyes.
- **Do not keep any parts of the body in front of the outlet for gaseous nitrogen (B).**

4.12 Mounting the exhaust hose

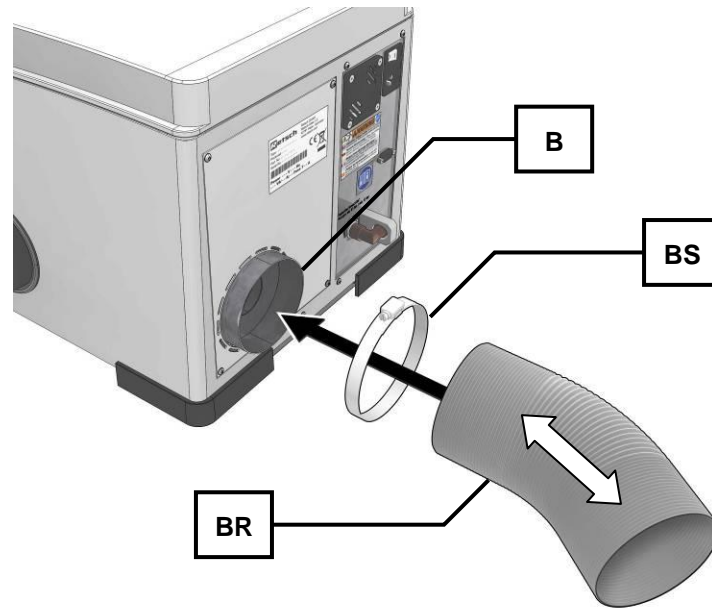

Fig. 16: Exhaust hose

- Fasten the exhaust hose (**BR**) with the clamp (**BS**) to the outlet (**B**).
- The exhaust hose can be extended up to 1 m

5 Operating the machine

5.1 Use of the machine for the intended purpose

Target group: operating company, operator

Name of machine model: CryoMill

This machine is a laboratory device and is suitable for the particularly gentle grinding and homogenisation of heat-sensitive, soft, fibrous, hard and brittle materials in a dry and wet state.

The CryoMill is designed exclusively for special grinding jars with screw-top lids (no standard grinding jars) with steel jacket. It is used for the fast pulverization of up to six samples simultaneously (depending on the type of grinding jar).

Available grinding jar volumes :

- 50ml;
- 35ml;
- 25ml;
- 10ml;
- 4 x 5ml including adapter; and
- 6 x 2ml Eppendorf vials.

The closed grinding system guarantees complete recovery of the samples . Due to the extremely short grinding time and the high final fineness of the grinding sample, the CryoMill is also ideally suitable for sample preparation for all spectral analyses.

Final fineness levels of up to 5 µm can be achieved depending on the grinding time and the specific properties of the sample material.

The optimal grinding jar filling is generally 1/3 of the grinding jar volume. Voluminous materials such as wool, leaves, grasses and similar are exceptions to this. A fill level of 70 - 80% is necessary here.

NOTICE

Area of use of the machine

- This machine is a laboratory machine designed for 8-hour single-shift operation.
- **This machine may not be used as a production machine nor is it intended for continuous operation.**

5.2 Operating elements and displays

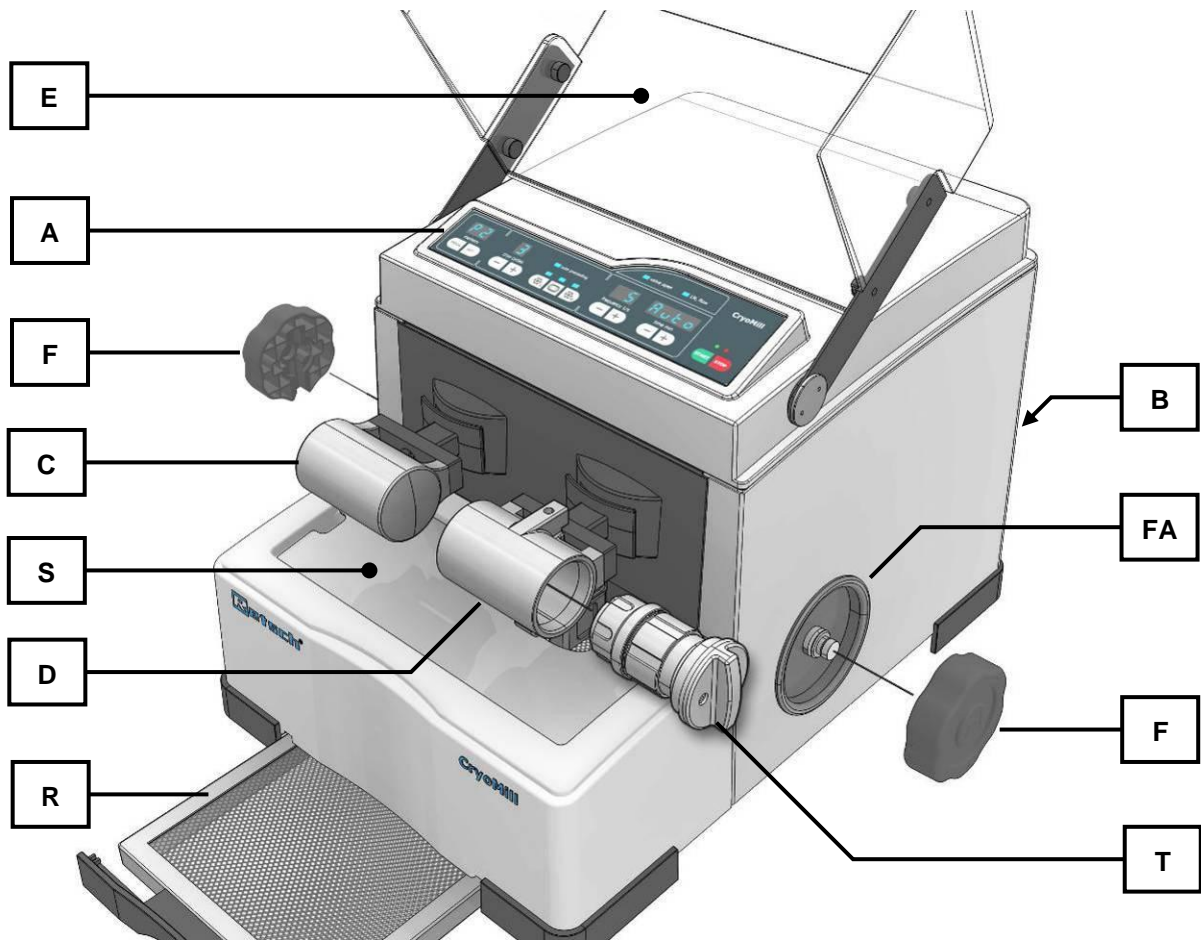

Fig. 17: Front view

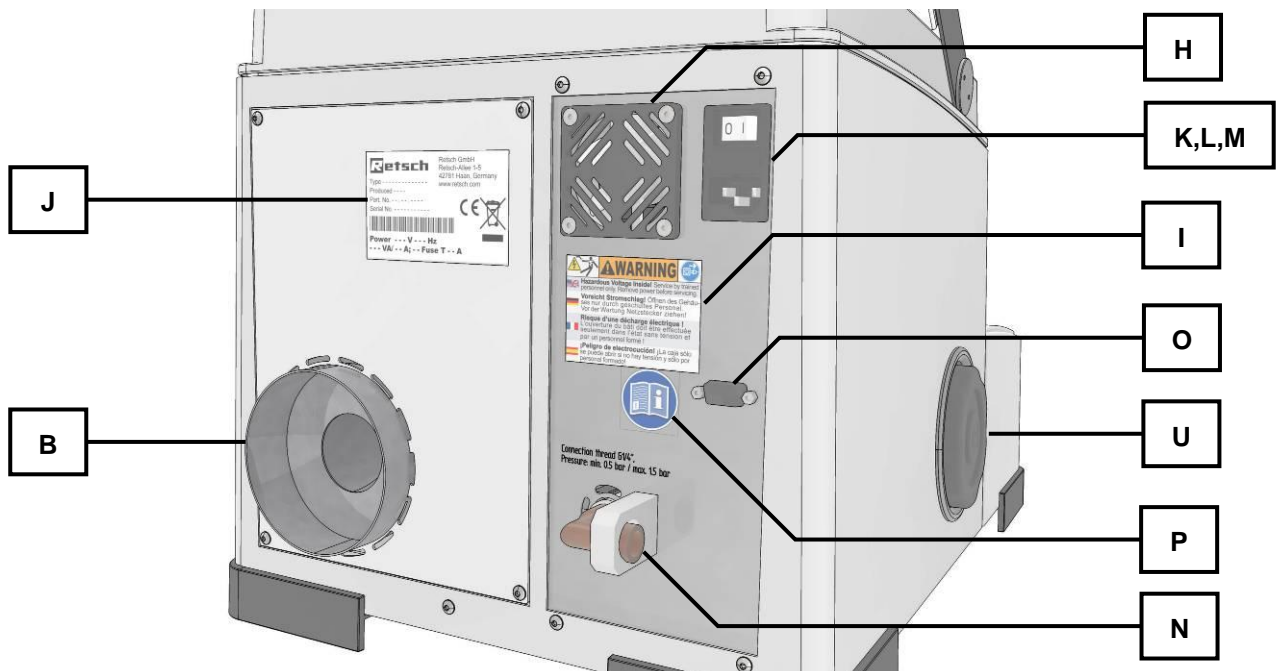

Fig. 18: Rear view

5.3 Summary table of device parts

Element	Description	Function
A	Display and control unit: See below for explanations	Time preselection, frequency preselection and starting/stopping the machine
B	Nitrogen gas outlet	Outlet for gaseous nitrogen
C	Counterweight left	Counterweight for the cooling jacket with grinding jar
D	Cooling jacket	Forms the cooling system together with the grinding jar (T)
E	Hood	Closes the grinding chamber
F	Opening aid	Can be mounted on the grinding jar cover for simple removal of the grinding jar
FA	Support for opening aid	Storage of the opening aid
H	Fan	Ventilates the motor and the interior of the mill
I	Caution remove mains plug sign	Safety instruction
J	Type plate	Information about the device and connected loads
K	ON / OFF switch	Switches the device on and off
L	Fuse drawer	Accommodates two glass fuses
M	Connector	Connector for the mains lead of the device
N	Cooling agent connection	Connection for liquid nitrogen
O	RS232 interface	Enables updating of the operating software
P	Observe operating instructions sign	Safety instruction
R	Condensation collecting filter	Collects the condensation from the cooling system and allows it to evaporate
S	Drip tray	Housing protection
T	Grinding jar	Forms the cooling system together with the cooling jacket (D)

5.4 Operating elements and displays

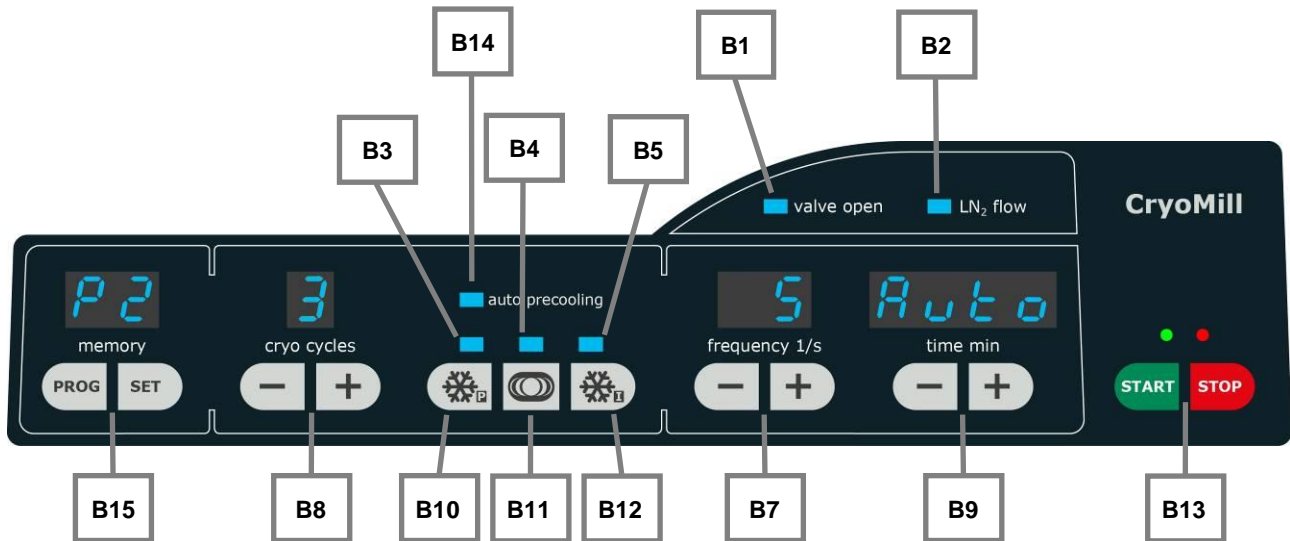

Fig. 19: Control unit

Element	Description	Function
B1	LED on – valve open LED off – valve closed	Indicates whether the internal solenoid valve on the liquid nitrogen supply line is open or closed.
B2	LED on – liquid nitrogen is flowing LED off – no liquid nitrogen	Indicates that liquid nitrogen is flowing into the device.
B3	LED precooling is running (V _{kz})	Precooling is taking place / lights up when values are set
B4	LED grinding is running (M _z)	The sample is ground / lights up when values are set
B5	LED intermediate cooling is running (Z _{kz})	Intermediate cooling is taking place / lights up when values are set
B7	Frequency minus button	In setting mode and in operating mode: reduces the set frequency by 1 Hz (1/s). Continuous pressing switches on fast scrolling of numbers.
	Frequency plus button	In setting mode and in operating mode: increases the set frequency by 1 Hz (1/s). Continuous pressing switches on fast scrolling of numbers.
B8	Cooling cycle minus button	Reduces the number of total cycles by 1
	Cooling cycle plus button	Increases the number of total cycles by 1
B9	Time minus button	In setting mode and in operating mode: Reducing the set <ul style="list-style-type: none"> • Precooling • Grinding time • Intermediate cooling time

	Time plus button	In setting mode and in operating mode: Increasing the set <ul style="list-style-type: none"> • Precooling • Grinding time • Intermediate cooling time
B10	Setting precooling	Preselection button to set the precooling / switching automatic precooling on or off)
B11	Setting grinding	Preselection button to set the grinding time
B12	Setting intermediate cooling	Preselection button to set the intermediate cooling time
B13	Start button Green LED	Starts grinding operation Indicates grinding operation
	Stop button Red LED and ON	Interrupts or ends grinding operation, places the machine in stand-by mode
B14	LED - auto precooling	Indicates whether the automatic precooling is switched on
B15	PROG button	Button to select a program
	SET button	Button starts / saves a program editing

5.5 Inserting the grinding jar

 **CAUTION**

Danger of injury and frostbite

Escape of liquid nitrogen

- Liquid nitrogen has a temperature of -196 °C and may cause injuries similar to burns on skin or eye contact or frostbite.
- **Never switch the machine on without tightly closed cooling casing.**

 **CAUTION**

Crushed or bruised fingers

Falling grinding chamber protective hood

- The protective hood of the grinding chamber can cause crushed or bruised fingers if it falls down.
- **Hold the flap tight when closing.**

5.5.1 Inserting and removing CryoMill special grinding jar

 **CAUTION**

Clogged piping

Formation of ice

- Ice or foreign matter can clog the pipe and subsequently cause malfunctioning.

Keep the cooling system and the supply pipe dry and free of foreign matter.

- **Do not insert the grinding jar if it is damp or covered with frost.**
- **Use the cooling jacket sealing plug (KA) if you are not going to use the device for a long time.**
- **Do not let the device run without supervision.**

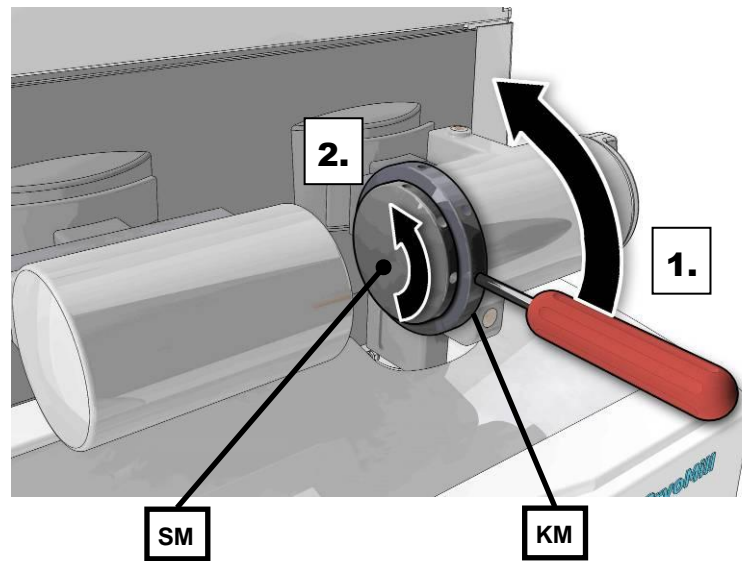

Fig. 20: Dismantling the grinding jar retaining device

- Unscrew the lock nut (KM).
- Remove the screw (SM).

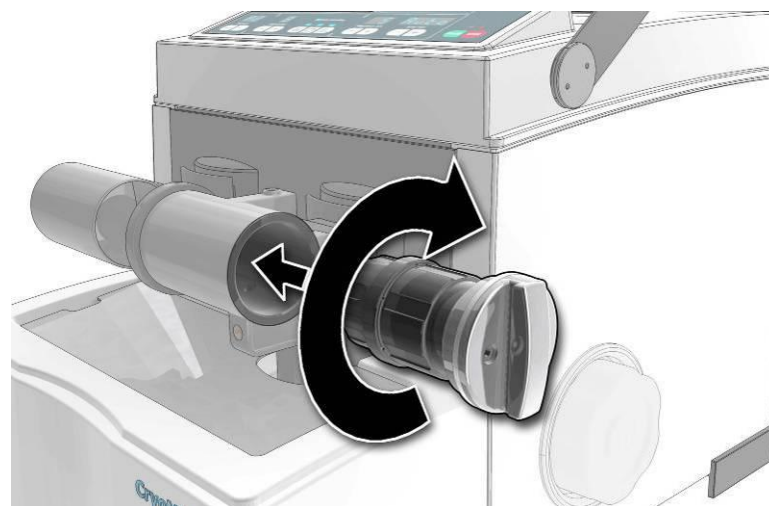

Fig. 21: Inserting the grinding jar

- Insert the special grinding jar filled with the grinding material and grinding balls into the cooling jacket .
- Twist the grinding jar in completely.

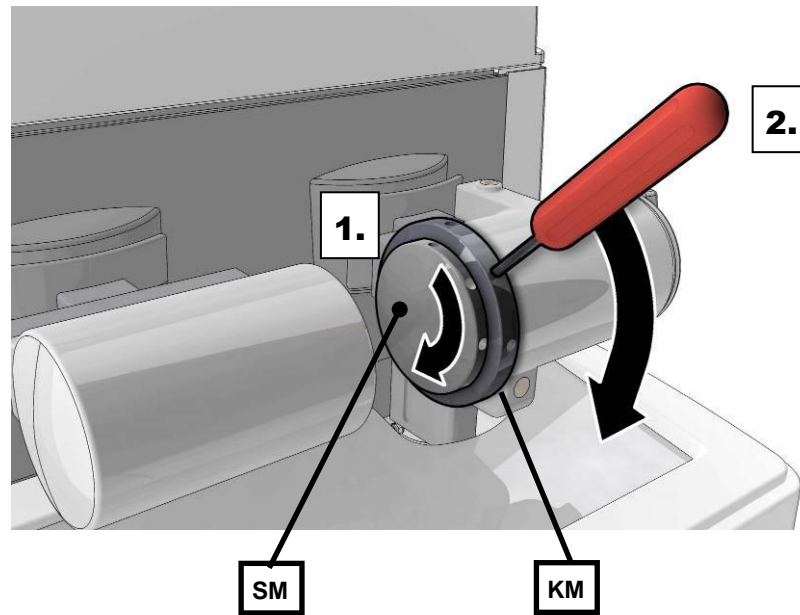

Fig. 22: Securing the grinding jar

- First tighten the screw (SM) by hand (hand-tight).
- Then tighten the lock nut against the cooling jacket. Use the locking pin provided to do this.

Ensure that the grinding jar is tightly screwed to the cooling jacket, otherwise liquid nitrogen can escape.

The lock screw (SM) must be screwed tight and secured with the lock nut so that no sample material escapes from the grinding jar.

 **CAUTION**

Risk of injury to eyes and skin

The cooling jacket and grinding jar reach very low temperatures during grinding.

- Risk of injury to eyes and skin from severe frostbite
- **As a matter of principle, always wear goggles and protective gloves when opening the cooling jacket and the grinding jar.**



Use the opening aid (F) that is kept on the side of the device to remove the grinding jar .

- Unscrew the lock nut (KM)
- Remove the screw (SM)
- Mount the opening aid (F) on the grinding jar and open it.

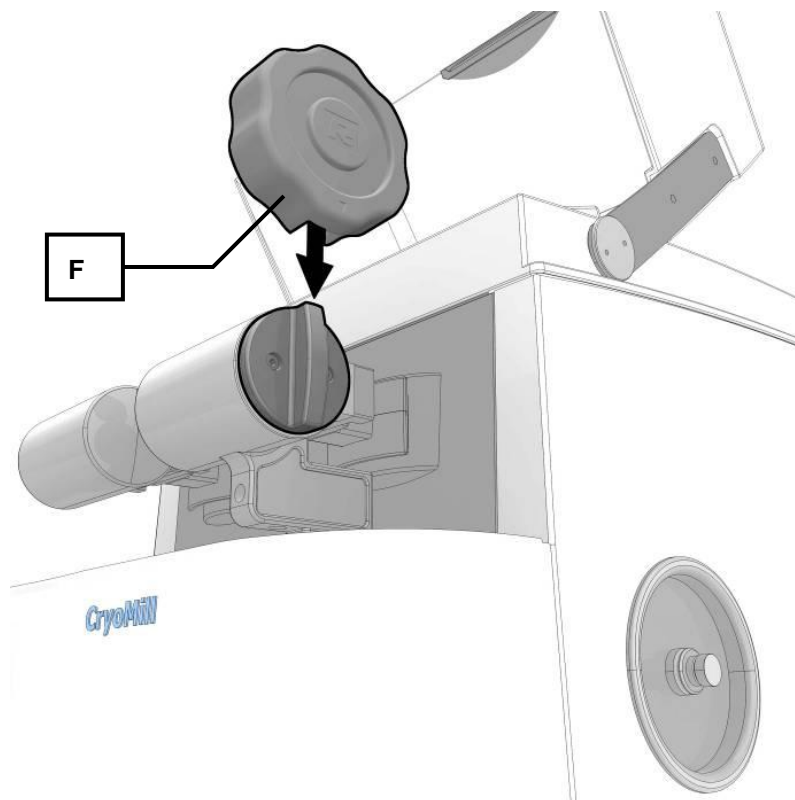

Fig. 23: Using the opening aid

NOTE

1.H0017

Damage to the PTFE grinding jar

- The threading on the grinding jar can become damaged.
- **When it is being inserted into the device, the PTFE grinding jar must be at room temperature and must not be pre-cooled.**

5.5.2 Inserting the cooling jacket sealing plug

NOTICE

Blocked pipe

Ice formation

- Ice or impurities can block pipes and thereby cause malfunctions.
- **Insert the cooling jacket seal (KA) as soon as you are no longer using the device.**

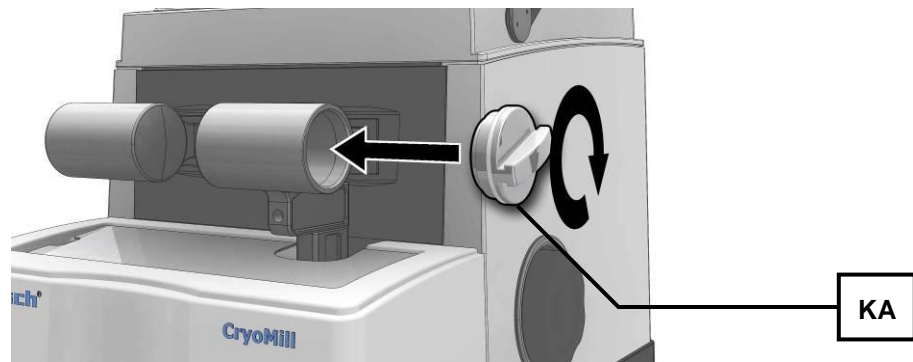

Fig. 24: Inserting the cooling jacket seal

5.5.3 Insert the adapter for 4/2 x 5 ml grinding jar

You can operate the CryoMill with 4 or 2 (5 ml) grinding jars.

- Insert the 5 ml grinding jars into the adapter as shown in the following diagram.

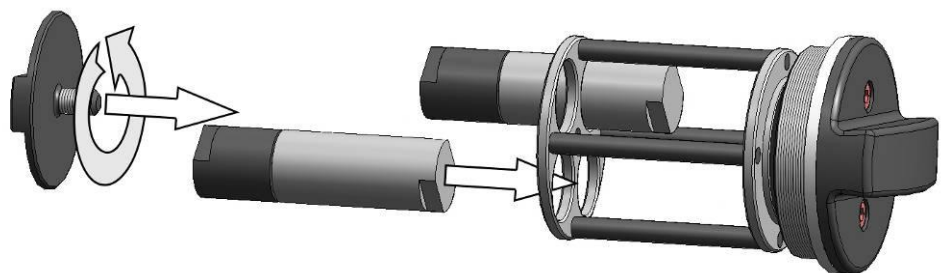

Fig. 25: Inserting a 5ml grinding jar

Note the positioning of the grinding jars. If you are using two grinding jars, these must be inserted in opposite openings.

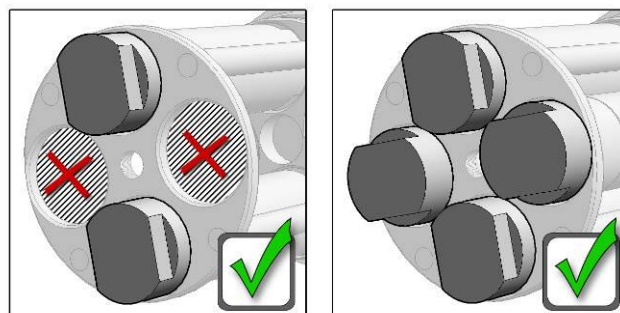

Fig. 26: 5ml grinding jar position

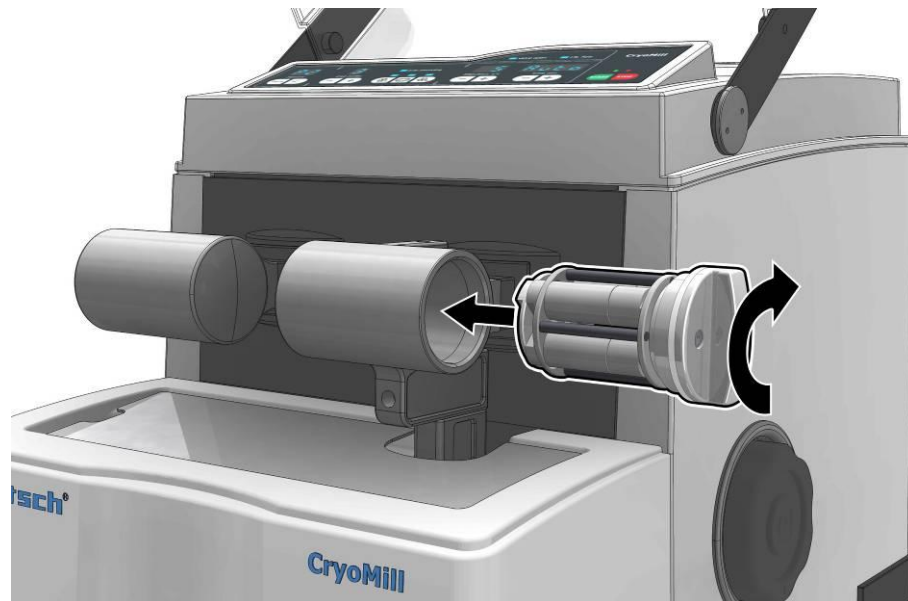

Fig. 27: Inserting the grinding jar adapter

5.5.4 Insert the adapter for 6 / 4 / 2 x 2-ml Eppendorf reaction vial

NOTICE

Breaking of Eppendorf reaction vials

Changing material properties

- The Eppendorf reaction vials that are available as accessories change their material properties during the cryogen grinding.
- **Do not reuse reaction vials after the cryogen grinding.**
- **Do not insert reaction vials in centrifuges after the cryogen grinding**
- **Grinding may take place with a maximum 25Hz.**

You can operate the CryoMill with 2, 4 or 6 Eppendorf reaction vials (2ml).

NOTICE

Grinding with Eppendorf reaction vials may only take place with a maximum 25Hz. **(frequency 1/s)**

- Insert the 2ml Eppendorf reaction vials into the adapter for reaction vials as shown in the diagram below.

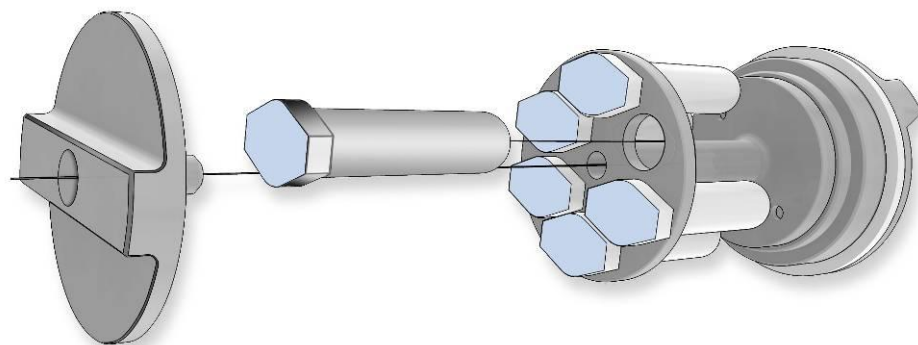

Fig. 28: Inserting 2ml Eppendorf reaction vials

Note the positioning of the Eppendorf reaction vials. If you are using two or four reaction vials, these must be inserted in opposite openings.

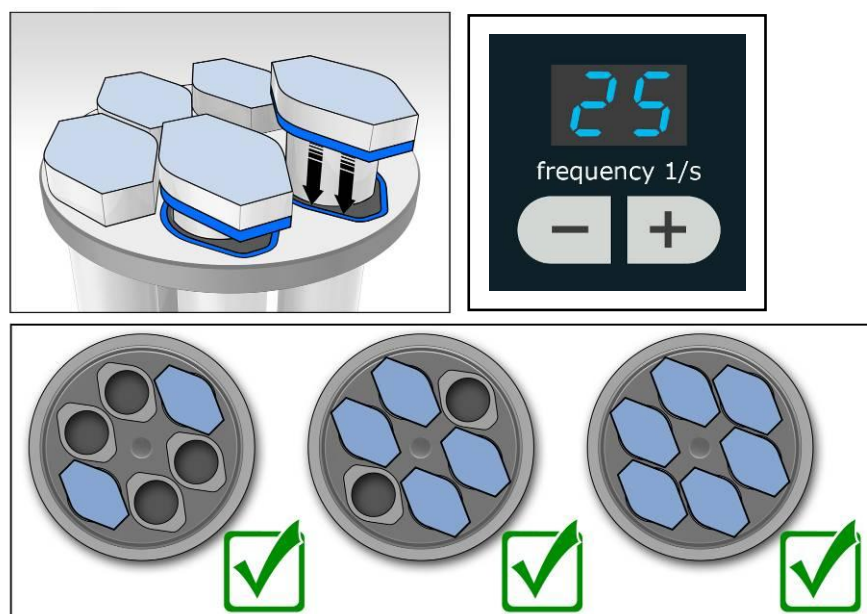

Fig. 29: Position of 2 ml reaction vials

5.6 Explanations of the grinding cycles

You can deploy the CryoMill for grinding with cooling or grinding without cooling.

5.6.1 Grinding without cooling

- Switch the CryoMill on at the main switch.
- Set the cryo cycles to - .



- Set the desired grinding time (B9)+(B11).
- Press the START button.

The START LED lights up. The remaining grinding time and the set frequency are displayed.

5.6.2 Grinding with cooling

The following program points can be set when grinding with cooling.

- precooling (Vkz)
- grinding time (Mz)
- intermediate cooling time (Zkz)
- cryo cycles (Number of cooling/grinding cycles)
- frequency 1/s (Grinding frequency)

A single grinding cycle consists of the precooling and the set grinding time. The intermediate cooling time does not apply in the case of a single grinding cycle.

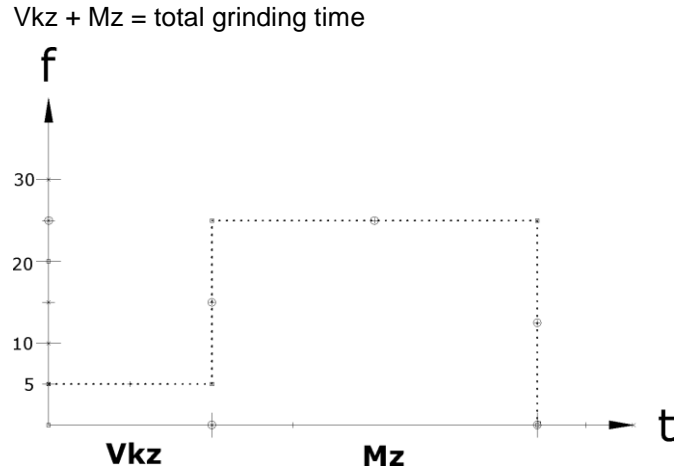

Fig. 30: Sequence of a single grinding cycle

Multiple grinding cycles consist of the precooling, the set grinding time and the intermediate cooling time.

Number of cryo cycles: n

$$Vkz + (n-1) (Mz + Zkz) + Mz = \text{total grinding time}$$

Precooling + [(number of set cryo cycles) - 1] X (grinding time + intermediate cooling time) + grinding time = total grinding time

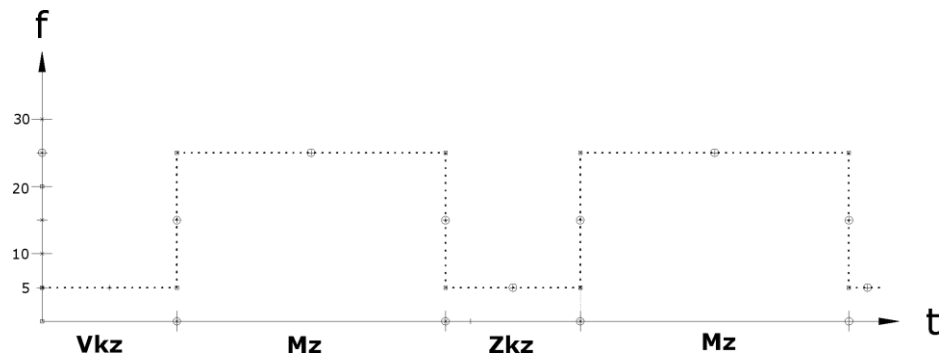

Fig. 31: Sequence of two grinding cycles

5.7 Programs

5.7.1 Grinding without program

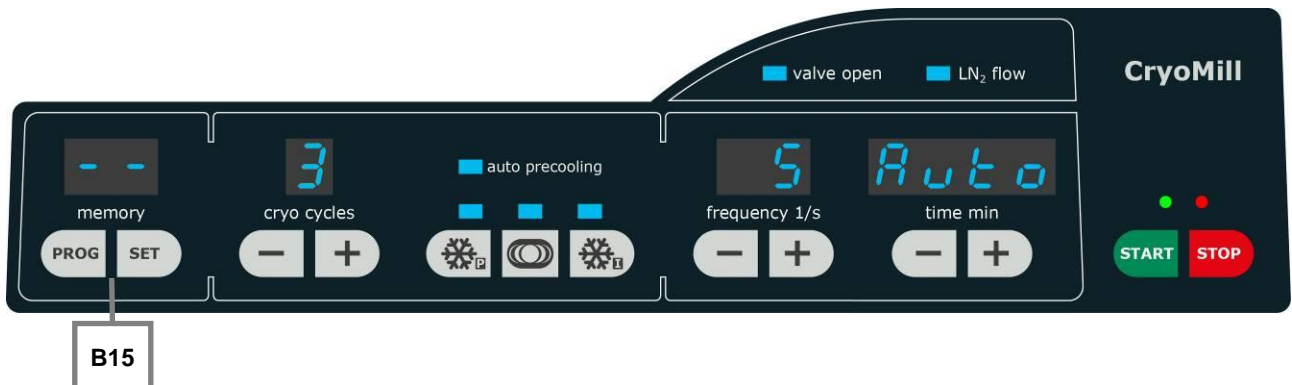
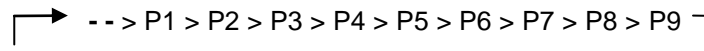

Fig. 32: Grinding without program

- Press the PROG button (**B15**) until “- -” is shown in the **memory** display.

The display advances one program each time the button is pressed



- The SET button (**B15**) is blocked in the “- -” mode

5.7.2 Grinding with program

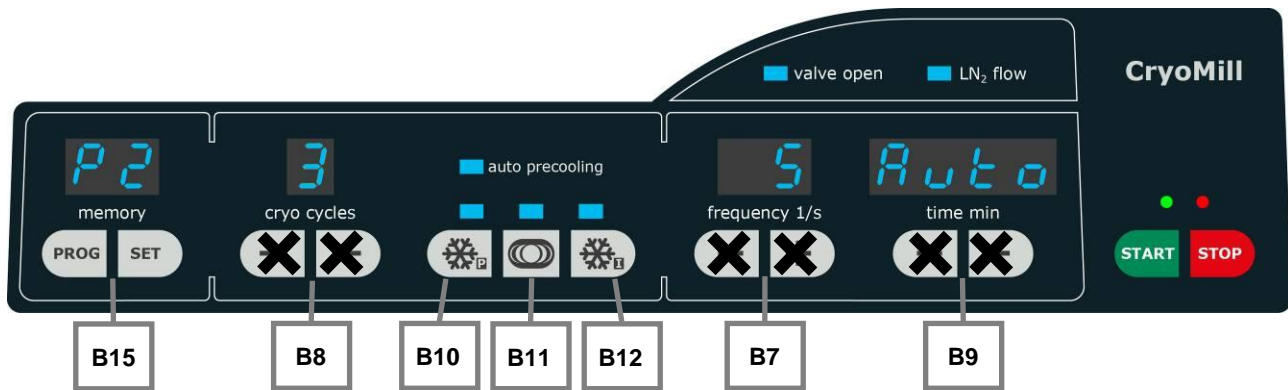

Fig. 33: Grinding with program

5.7.2.1 Selection of a program

- Press the PROG button (**B15**) until the required program is shown in the **memory** display.
- The display advances one program each time the button is pressed .
- The buttons **B8**, **B7**, **B9** are blocked due to the selection of a program.

5.7.2.2 Display of the program grinding parameters

Precooling

- Press the precooling button (**B10**).
- The set time for precooling appears in the **time min (B9)** display.

Grinding time

- Press the grinding time button (**B11**).
- The set time for the grinding time appears in the **time min (B9)** display.

Intermediate cooling

- Press the intermediate cooling button (**B12**).
- The set time for the intermediate cooling appears in the **time min (B9)** display.

5.7.2.3 Create/change a program

- Press the PROG button (**B15**) until the required program (memory space) is displayed in the **memory** display.
- Press the SET button (**B15**).
- All displays and the corresponding LEDs for which settings are possible light up or flash.

- Set the parameters for grinding as described in the following chapters:
 - Number of grinding cycles
 - Precooling
 - Grinding time
 - Intermediate cooling time
 - Grinding frequency
- It is possible to cancel at any time using the PROG button (**B15**)

- Press the SET button (**B15**).
- Pressing the SET BUTTON (**B15**) again stores all parameters in the program.

5.7.2.4 Delete program

- Press the PROG button (**B15**) until the program to be deleted is displayed in the **memory** display.
- Press the shortcut SET (**B15**) and - (**B8**) for at least 5 seconds.

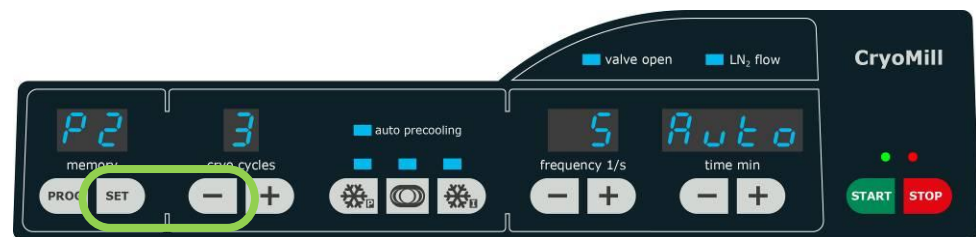

Fig. 34: Deleting a program

- The program is deleted and the parameters are assigned with the values “0” or “-”.
- It is not possible to start a deleted program.

5.8 Setting grinding cycles



Fig. 35: Setting the grinding cycles

- Switch the CryoMill on at the main switch.
- After switching on, the last used grinding parameters are displayed and can be used.
- You can set 0 (“-”) to 9 grinding cycles

NOTICE

If 0 (“-”) CryoCycles are set, the grinding is conducted without nitrogen. In this case the buttons **B10**, **B11** and **B12** are blocked.

- The first cycle consists of the precooling phase and grinding time
- Cycles 2 to 9 each comprise an intermediate cooling and grinding.
- Press the respective buttons (B8) to set the grinding cycles.
- + Pressing briefly increases the number.
- - Pressing briefly reduces the number.
- The display runs more quickly when pressed longer.

5.9 Setting the precooling time

NOTICE

The machine runs at a fixed frequency of 5 Hz during the precooling and intermediate cooling.

A range of from 30 seconds to 99 minutes can be set for precooling.

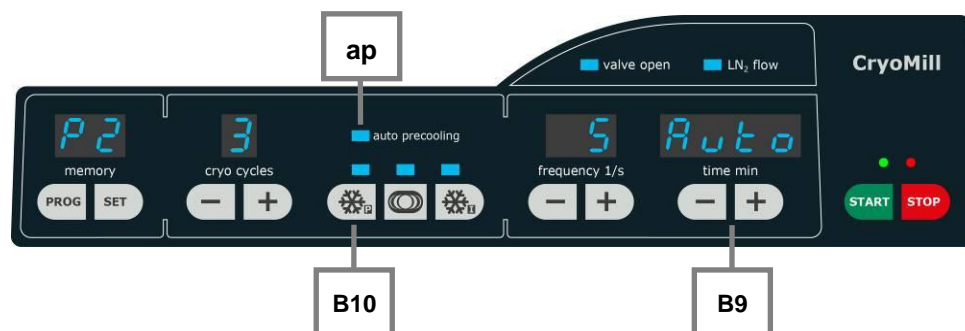

Fig. 36: Setting precooling

After switching on, the last used grinding parameters are displayed and can be used.

- Switch the CryoMill on at the main switch.
- Press the button (B10) to set precooling
- The precooling LED lights up.

You can choose between two precooling versions:

5.9.1 Precooling with definable precooling time

- Use the buttons (B9) to set precooling.
- + Pressing briefly increases the duration.
- - Pressing briefly shortens the duration.

The display runs more quickly when pressed longer.

5.9.2 Automatic precooling

In the case of automatic precooling the grinding only starts once the entire system has been sufficiently cooled. This is checked by a sensor (see chapter >>Connecting the cooling agent supply <<)

Switch automatic precooling on

- Press the button (B10) for at least 2 seconds.

- The auto precooling (ap) LED is lit up.
- "Auto" is shown in the **time min** display.

Switch automatic precooling off

- Press the button (B10) for at least 2 seconds.
- The auto precooling (ap) LED is extinguished.
- "08:00" is shown in the **time min** display.

5.10 Setting the grinding time

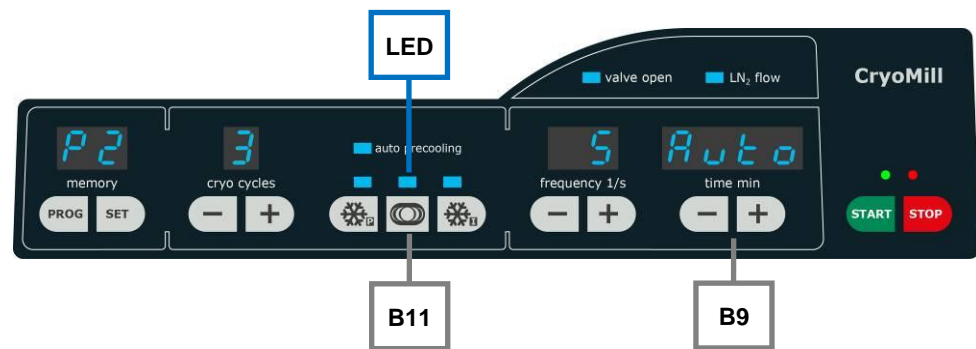

Fig. 37: Setting the grinding time

- Press the button (B11) to set the grinding time.
- The grinding time **LED** lights up.
- Use the buttons (B9) to set the grinding time (5 to 30 Hz in 1Hz steps).
 - **+** Pressing briefly increases the duration.
 - **-** Pressing briefly shortens the duration.

The display runs more quickly when pressed longer.

NOTICE

In the case of grinding without cooling, the grinding time can be set directly using the buttons (B9).

5.11 Setting the duration of intermediate cooling

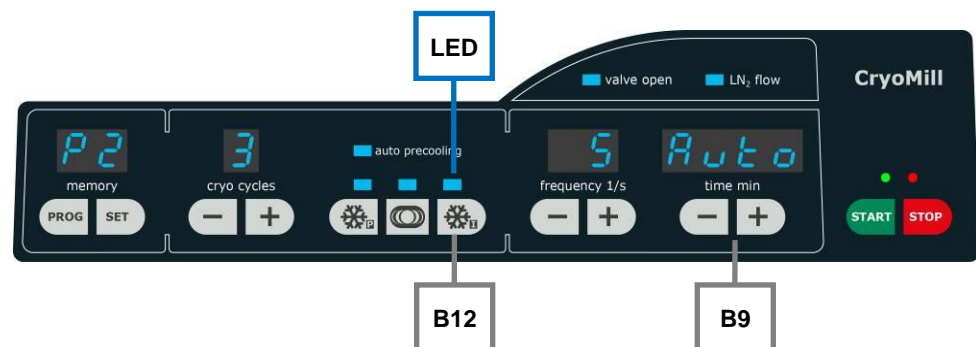

Fig. 38: Setting the intermediate cooling

- Press the button (B12) to set the intermediate cooling .
The intermediate cooling time LED lights up.
 - Use the buttons (B9) to set the intermediate cooling time (30 seconds to 99:00 minutes).
 - + Pressing briefly increases the duration.
 - - Pressing briefly shortens the duration.
- The display runs more quickly when pressed longer.

5.12 Setting the grinding frequency

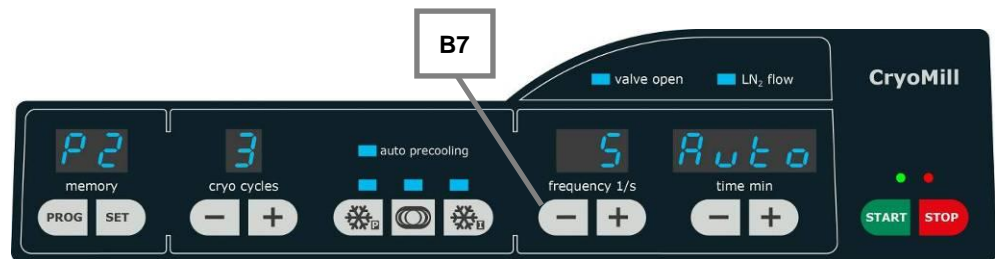

Fig. 39: Frequency 1/s

- Switch the CryoMill on at the main switch.
- It is only possible to adjust the grinding frequency if the button (B11) for setting the grinding parameters has been pressed and the LED (B11) is lit up.
- Press the button (B11).
 - Press the respective buttons (B7) to set the grinding frequency .
- The selectable frequency range is from 3 to 30 Hz.
- + Pressing briefly increases the frequency.
 - - Pressing briefly reduces the frequency.
- The display runs more quickly when pressed longer.
- The frequency of precooling and intermediate cooling is fixed at 5 Hz. The frequency cannot be adjusted while setting the precooling or intermediate cooling time.

5.13 Starting the grinding process



CAUTION

Danger of injury and frostbite

Escape of liquid nitrogen

- Liquid nitrogen has a temperature of -196 °C and may cause injuries similar to burns on skin or eye contact or frostbite.
- **Never switch the machine on without tightly closed cooling casing.**

NOTICE

The grinding process can only be started if the hood is closed.

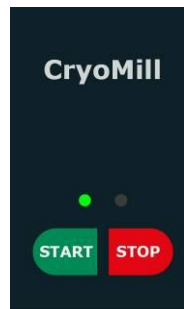

Fig. 40: Starting the grinding process

- Press the START button to start the grinding process.
- The Start LED (green) lights up. At the same time the solenoid valve opens and liquid nitrogen can flow into the cooling system.

5.14 Interrupting and continuing the grinding process

5.14.1 Pausing grinding

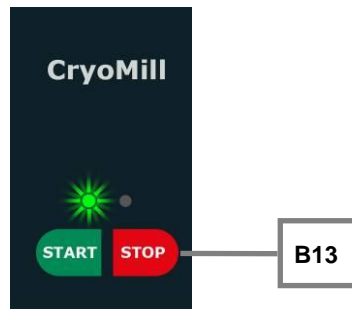

Fig. 41: Pausing grinding

- Press the STOP button (**B13**) once.
- Grinding is interrupted and the LED above the START button flashes.

5.14.2 Cancelling grinding

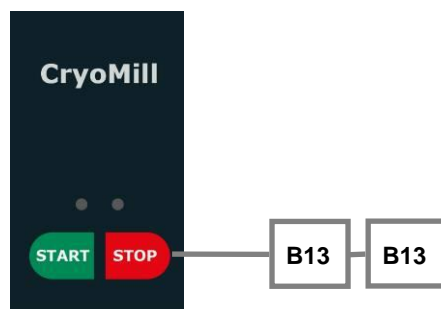

Fig. 42:

- Press the STOP button (**B13**) twice.
- The grinding is ended and the two LEDs above the START and STOP buttons are off.

5.15 Stopping the grinding process

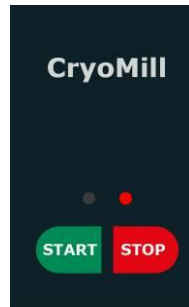

Fig. 43: Ending the grinding process

- Press the STOP button to end the grinding process.

The STOP LED (red) lights up. At the same time the solenoid valve closes.

In the event that the supply of liquid nitrogen has been interrupted during operation, this is indicated by the flashing of the remaining time LED (B6) at the end of the grinding time.

Pressing once interrupts the grinding process, for example to appraise the grinding sample. The remaining grinding time is still visible on the display.

By pressing the start button again, the mill continues running until the grinding time has completely expired.

Pressing the stop button twice aborts the grinding process. The machine is now in start mode.

By pressing the start button, the display is activated again and the grinding time is reset to the last start setting.

The duration can be changed during the grinding process. The grinding process is automatically ended on expiry of the grinding time. The display is reset to the last value started.

5.16 Operating hours display

- Switch the device off at the mains switch.



Fig. 44: Switching the device on and off

- Keep the buttons cryo cycles (B8) + and frequency (B7) - pressed simultaneously and with the buttons pressed, switch the device on at the mains switch.

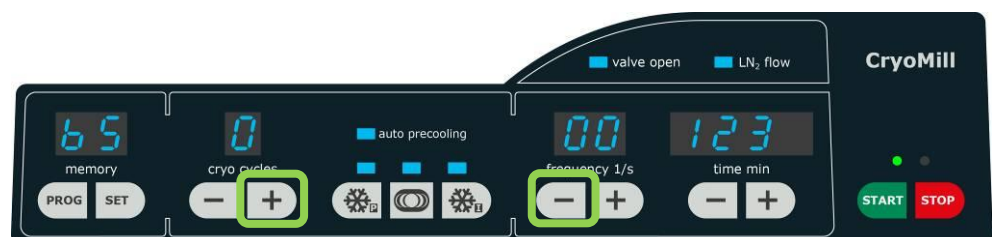



Fig. 45: Display of the operating hours

The total operating time in hours is displayed. The maximum value that can be depicted is 999999 hours. The letters bS are displayed in the first two places.

Examples:

bS0 00 012 = 12 hours operating time

bS1 23 456 = 123456 hours operating time

- Press the STOP button to exit the operating hours display

5.17 Operating software display

- Switch the device off at the mains switch.

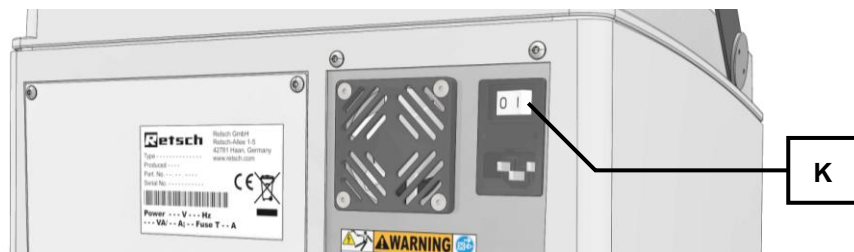

Fig. 46: Switching the device on and off

- Keep the buttons cryo cycles (B8) + and frequency (B7) + pressed simultaneously and...
- ...with the buttons pressed, switch on the device at the mains switch.

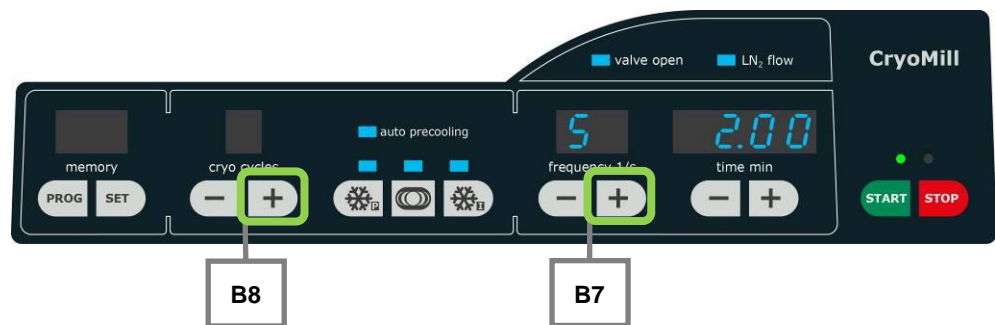

Fig. 47: Display of the software version

The current version of the operating software is displayed across the two right-hand display windows. The letter S is shown in first place.

Examples:

S 1.23 = Version 1.23 of the operating software

S 2.00 = Version 2.00 of the operating software

- Press the STOP button to exit the display of the operating software.

5.18 Replacing the machine fuses

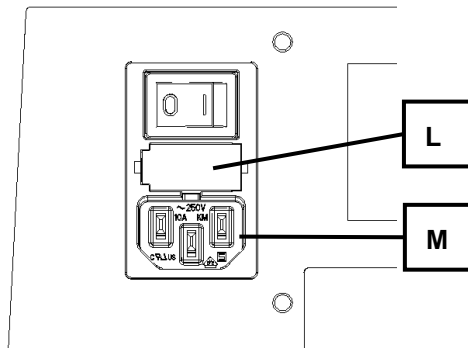

Fig. 48: Replacing the device fuses

The following glass fuses are needed for the CryoMill:
2 T4A

- Pull the mains plug from the connector (**M**).
- Press in the catch at the side. This releases the fuse holder (**L**) so that it can be pulled out.
- Replace the fuses.
- Push the fuse holder (**L**) in until it engages.

6 Working instructions

6.1 General

The CryoMill is an extremely modern, efficient product from Retsch GmbH.

Due to the large selection of accessories, the CryoMill has a wide range of potential applications in industrial and research laboratories.

It is primarily deployed in the chemical and pharmaceutical area, in mineralogy and biology etc.



CAUTION

2.V0004

Risk of explosion or fire

Changing sample properties

- Consider that the properties and therefore also the hazardousness of your sample can change during the grinding process.
- **Do not use any substances in this device which carry the risk of explosion or fire.**



CAUTION

Danger of personal injury

Dangerous nature of the sample

- Depending on the dangerous nature of your sample, take the necessary measures to rule out any danger to persons.
- **Observe the safety guidelines and datasheets of your sample material.**



6.2 The grinding process

- Insert your grinding jar filled with grinding sample and grinding ball/s into the grinding jar support as described in the chapter "Inserting the grinding jar".
- Close the hood.
- Set the grinding parameters.
- Open your external liquid nitrogen supply line.
- Start the device.

Do not open the hood during the grinding process.

The grinding jars are brought to a halt immediately by the built-in brake, however the grinding process can no longer be continued with the remaining grinding time.

The device must be restarted. The original parameters are available here.

6.3 Quantities of sample material and feed sizes

Recommended ball filling (unit)

Grinding jar nominal volume	Sample quantity	Max. feed size	Ø7 mm	Ø10 mm	Ø12 mm	Ø15 mm	Ø20 mm	Ø25 mm
5.0 ml	0.5 - 2.0 ml	2 mm	1 or 2	-	-	-	-	-
10.0 ml	2.0 – 4.0 ml	4 mm	-	1 to 2	1 to 2	-	-	-
25.0 ml	4.0 – 10.0 ml	6 mm	-	5 or 6	2 to 4	1 or 2	-	-
35.0 ml	6.0 - 15.0 ml	6 mm	-	6 to 9	4 to 6	2 or 3	1	-
50.0 ml	8.0 - 20.0 ml	8 mm	-	12 to 14	6 to 8	3 or 4	1	1

6.4 Working instructions

The grinding jar and its content are cooled by means of liquid nitrogen (LN2) until it is possible to grind soft materials such as rubber.

Precooling is required until the ideal grinding temperature is reached. The drive operates at a lower frequency (5Hz) here to prevent the moving parts of the device from freezing. The fan is switched on during precooling and blows the air heated by the motor in the front through the openings of the rocker arms into the grinding chamber. This warm air prevents the rocker arm bearing from cooling down. It is therefore also necessary to allow the fan to run on for a while after switching the grinding off.

In the preliminary tests an average precooling of approx. 10 to 15 minutes was determined. The grinding time was approx. 4 – 5 minutes.

The valve is switched off when the optimal temperature is reached. Grinding can begin as from this time and the valve will be switched on and off according to the temperature.

Grinding can also take place without cooling, in which case the cryo cycles are set to -.



Manual cooling is started by pressing the shortcut (B10) and (START B13). The valve remains open as long as the buttons are kept pressed.

7 Safety functions and fault display

7.1 Fault messages

rror cod	(FEHLER) BESCHREIBUNG	DEFECT DESCRIPTION TRANSLATION
E10	ANTRIEB ÜBERLASTET	DRIVE OVERLOAD
E21	FEHLER DREHZAHL	FAILURE ROTATION SPEED
E22	FEHLER TASTATUR	FAILURE KEYPAD
E24	FEHLER VENTIL	FAILURE VALVE
E41	FEHLER DREHZAHLSENSOR	FAILURE SPEED SENSOR
E42	FEHLER TEMPERATURSENSOR 1	FAILURE TEMPERATURE SENSOR 1
E43	FEHLER TEMPERATURSENSOR 2	FAILURE TEMPERATURE SENSOR 2
E51	FEHLER SICHERHEITSSCHALTER	SATETY SWITCH DEFECTIVE
E85	KEIN STICKSTOFF	NO LIQUID NITROGEN
E86	LECKAGE	LEAKAGE
H40	MASCHINE SCHLIESSEN	CLOSE MACHINE

8 Cleaning, wear and service

8.1 Cleaning

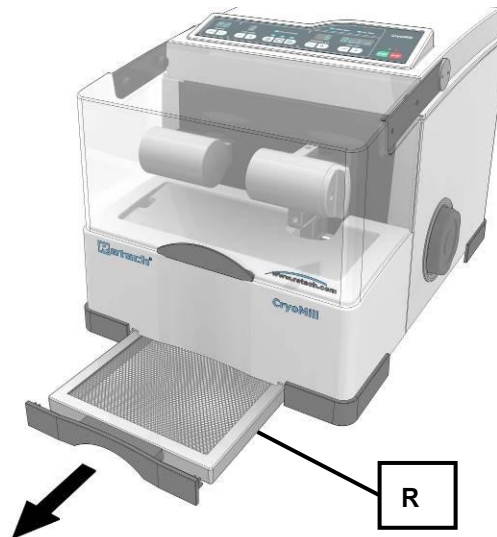

Fig. 49: Pulling out the condensation collecting filter

The condensation collecting filter must be cleaned regularly depending on the ambient conditions, the degree of use and the general air humidity.

- Pull out the condensation collecting filter (**R**).
- Clean the condensation collecting filter under running water with a little standard washing up liquid.
- Allow the collecting filter to dry and then insert in the device again.

8.2 Wear

The grinding tools may become worn, depending on the frequency of the grinding operation and the sample material. The grinding jars and the balls should be regularly checked for wear and replaced if necessary.

8.3 Wearing parts



CAUTION

Personal injury

Incorrect repairs

- This operating manual does not include instructions for repair.
- **For your own safety repairs should be carried out only by Retsch GmbH or an authorised representative (service technicians).**

8.4 Service

The grinding tools may become worn, depending on the frequency of the grinding operation and the sample material. The grinding jars and the balls should be regularly checked for wear and replaced if necessary.

8.5 Checks

Correct functioning of the hood switch must be checked regularly.

- Switch on the machine with switch (K).
- Start grinding operation with start button (B13 - Start).
- Lift the hood.

If there is an opening gap of a few cm the machine switches itself off and F04 appears in the display.

- Cancel F04 with stop button (B13 - Stop).

If this switching-off function does not take place the CryoMill must be checked immediately by Retsch-Service.

9 Safety and occupational health instructions



Danger of injury to eyes and skin

Frostbites through liquid nitrogen

- Liquid nitrogen has a temperature of -196 °C and may cause injuries similar to burns on skin or eye contact or cause frostbite.
- **Always use goggles and wear protective gloves when opening the cooling casing and the grinding jar.**



Use of liquid nitrogen

- Retsch GmbH rules out any liability claims that may arise in the use of liquid nitrogen or similar cooling agents.
- **Please observe the safety regulations of the cooling liquid supplier.**



9.1 General

This section summarises the general occupational health and safety guidelines for the handling of liquid nitrogen.



Handling liquid nitrogen

General hazardous situations

- The following hazardous situations may arise in the handling of liquid

nitrogen: oxygen deficiency situations, cryogenic burns, danger of explosion, oxygen enrichment

- **All users must be informed about the dangers of working with liquid nitrogen in order to be able to work safely.**
-

9.2 Safety instructions on the handling of liquid nitrogen

9.3 Oxygen deficiency

The main components of air according to volumes are as follows:

- Oxygen O₂ 21 %
- Nitrogen N₂ 78 %
- Argon Ar 1 %

The gases contained in the atmosphere are not toxic. However, a change in concentration (in particular changes to the oxygen concentration) may have effects on life and burns. It is therefore essential for the air breathed in to contain sufficient oxygen (> 19 %).

Humans cannot detect changes in the composition of air within the time that will actually be necessary because the components are colourless and odourless.

9.3.1 Dangers

A danger of suffocation exists as a result of the normal evaporation of the liquid nitrogen that pushes out the oxygen in the air. An oxygen deficiency is dangerous and can cause death through suffocation. The reaction of the organism to oxygen deficiency will differ greatly depending on the individual. It is not possible to provide precise and generally applicable information on the symptoms of an oxygen deficiency.

Example: under normal conditions (20° C; 1013 mbars) 1 l liquid nitrogen evaporates to produce 680 l nitrogen gas.

9.3.2 Causes

An oxygen deficiency may arise during the following work or in the following conditions:

- Nitrogen as liquid or gas
- Natural evaporation of liquid nitrogen
- Refilling of liquid nitrogen
- Leaks in containers for liquid or gaseous nitrogen
- Defect in the air feed or outlet
- Tipping over of the container

This list is not complete.

9.3.3 Recommendations

In order to prevent the danger of an oxygen deficiency, the following measures must be taken.

The vessel:

- must be kept in a vertical position.
- must be provided with a suitable insulating lid.
- must be protected from direct sunlight and may not be set up near heat sources.

- may not be transported in vehicles in filled state.
- must be protected from impact, knocks and rapid movements.

- Ventilate all installation rooms constantly and appropriately.
- Wear protective clothing (suitable gloves, goggles or face protection and safety shoes).
- Check the oxygen content of the room constantly.
- Always carry an oxygen metre.
- Only trained personnel may work with liquid nitrogen.

This list is not complete.

9.3.4 General conduct in the case of an accident

In the case of an accident from oxygen deficiency the following regulations should be observed.

- Secure the surrounding area to avoid any subsequent accidents.
- Act quickly.
- The rescuers must take measures to protect themselves (respiratory protection device).
- Move the injured persons from the hazardous area.
- Observe the company instructions for emergencies.
- Ventilate the rooms affected sufficiently.
- Investigate the cause of the accident.

This list is not complete.

9.4 Cryogenic burns

Liquid nitrogen is very cold (-196° C).

The surfaces of vessels that were in contact in liquid nitrogen (in particular during the filling process) may cause skin burns on contact.

9.4.1 Dangers

Cryogenic liquids may:

- bring about burns to the human body
- make specific materials (metal and plastic) that are not suitable for low temperatures brittle
- generate strong misting depending on atmospheric humidity

9.4.2 Causes

There are two types of cryogenic burns:

9.4.2.1 Burns through splashes

When handling samples and in general when handling liquid nitrogen, personnel must protect themselves from splashes. They can cause cryogenic burns with serious consequential damage, in particular to eyes and face.

9.4.2.2 Burns through contact

Contact of the skin with cold material causes frostbite or cryogenic burns.

The interior of vessels or the samples may never be touched or held with bare hands.

9.4.3 Recommendations

In order to prevent the danger of burning the following points must be observed:

- Never bring cryogenic liquids in contact with the skin.
- Never touch the cold non-isolated or iced walls of a vessel.
- Wear personal protective equipment (suitable gloves, goggles or face protection and safety shoes).
- Keep the vessel upright.
- Use suitable material (e.g. metal hose or PTFE hose) to refill.
- Train personnel.

This list is not complete.

9.4.4 General rules of conduct for splashes with liquid nitrogen

9.4.4.1 To the eyes

- Rinse eyes with much water for 15 min.
- Follow the company instructions for emergencies.
- Consult a doctor

9.4.4.2 On the skin

- Do not rub.
- If possible remove or loosen clothing.
- Slowly and gradually warm the parts affected.
- Do not apply anything to the burnt area.
- Follow the company instructions for emergencies.
- Consult a doctor.

Both lists are not complete.

9.5 Danger of explosion

9.5.1 Dangers

The evaporation of liquid nitrogen may lead to an overpressure in the vessel.

9.5.2 Causes

An increase in the vessel may be attributable to:

- incorrect set-up (use of a closable lid)
- icing on the neck and on the insulating lid

This list is not complete.

9.5.3 Recommendations

To avoid the danger of explosion:

- Always use suitable insulating lids (pay attention to waste gas opening).
- Observe filling levels to avoid the formation of ice on the insulating lid.
- Set up the vessel in dry and roofed rooms.
- Monitor atmospheric humidity in the installation room.
- Check vessel regularly for the collection of condensed water.
- Check vessel regularly for damage to surface or material damage

This list is not complete.

9.5.4 General conduct in the case of an accident

In the case of an accident from oxygen deficiency the following regulations should be observed.

- Secure the surrounding area to avoid any subsequent accidents.
- Act quickly.
- The rescuers must take measures to protect themselves (respiratory protection device).
- Move the injured persons from the hazardous area.
- Observe the company instructions for emergencies.
- Ventilate the rooms affected sufficiently.
- Investigate the cause of the accident.

This list is not complete.

9.6 Oxygen enrichment

9.6.1 Dangers

Oxygen enrichment may increase the danger of explosion and fire.

9.6.2 Causes

Oxygen may be condensed from the air if liquid nitrogen is used and similarly be liquefied because the boiling point of oxygen (approx. -183° C) is above that of nitrogen (-196° C).

9.6.3 Recommendations

The following points must be considered in the case of oxygen enrichment:

- Do not smoke.
- Where possible, keep easily inflammable materials away from the vessel.

- Remove all sources of fire (naked flame and light, spark producers, matches, lighters etc.).
- Ventilate installation rooms constantly and appropriately.
- Clean floor regularly.
- Train personnel.
- Wear personal protective equipment.
- Check oxygen content constantly.
- Always carry an oxygen metre.

This list is not complete

9.7 Surrounding area of the machine

9.7.1 Rooms

The room in which the machine is located must:

- permit operation without danger to the employees
- have a constantly running and appropriate ventilation system
- have a level and non-porous floor that is also able to bear the load of the vessel
- have safety datasheets on liquid nitrogen visible for all to see
- prevent unauthorised access
- permit the safe filling of the vessel
- permit accessibility to the vessel for inspection, cleaning and maintenance

This list is not complete.

10 Disposal

Please observe the respective statutory requirements with respect to disposal.

Information on disposal of electrical and electronic machines in the European Community.

Within the European Community the disposal of electrically operated devices is regulated by national provisions that are based on the EU Directive 2002/96/EC on Waste Electrical and Electronic Equipment (WEEE).

Accordingly, all machines supplied after 13.08.2005 in the business-to-business area to which this product is classified, may no longer be disposed of with municipal or household waste. To document this they have the following label:

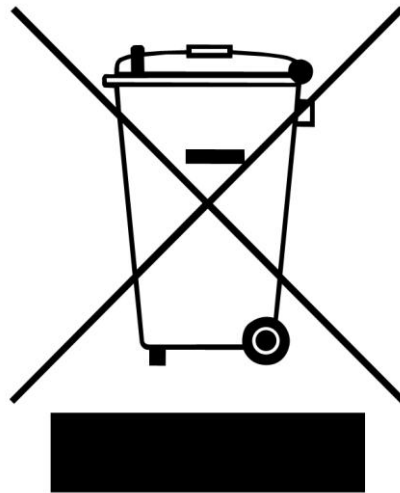

Fig. 50: Disposal label

Since the disposal regulations within the EU may differ from country to country we would request you to consult your supplier.

11 Index

4		D	
4 A.....	47	Danger of explosion.....	56
5		Dangers	54, 55, 56, 57
5ml grinding jar position.....	35	Degree of protection	12
A		Delete program	40
Amperage	19	Depth.....	12
Assign/change memory space	39	Device designation.....	18
Atmospheric humidity	13	Diagram of the cooling system	22
Automatic precooling	41	Dimensions and weight.....	12
B		Dismantling the grinding jar retaining device.....	32
Bar code	18	Display of the grinding parameters	39
bS.....	46	Display of the operating hours	46
C		Display of the software version.....	46
Capacity	19	Disposal	59
Causes.....	54, 55, 56, 57	Disposal label.....	18
CE marking	18	Disposal label.....	59
Changes	6	E	
Checks	52	Electrical connection	19
Clean.....	51	Emission value with regard to workplace.....	11
Cleaning.....	51	Emissions.....	11
Cleaning, wear and service	51	Ending the grinding process	45
Cold air outlet.....	24	Eppendorf	36
Condensation.....	23	Eppendorf reaction vial	36
Condensation collecting filter.....	16, 51	Exhaust hose	24, 25
Conditions for the place of installation.....	13	Explanations of the grinding cycles	37
Confirmation	10	Explanations of the safety warnings	7
Connecting the cooling agent feed	19	External fuse	19
Connection cable	19	F	
Cooling jacket	32	Fault messages.....	50
Cooling jacket seal.....	21	Fill level	26
Copyright	6	Final fineness levels.....	26
Create/change a program.....	39	Flashing of the remaining time LED.....	45
cryo cycles	37	frequency 1/s	37
Cryogenic burns.....	55	Frequency range.....	43
		Front view	27

Function of the hood switch	52	Intermediate cooling.....	43
Fuse holder	47	Intermediate cooling time	37
Fuse strength	19	Interrupting and continuing the grinding process	44
Fuse type	19		
G		L	
G 1/4 inch	23	Laboratory mill	11
General	48, 52	Layer of ice	23
General conduct in the case of an accident .	55, 57	Liquid nitrogen supply interrupted.....	45
General rules of conduct for splashes with liquid nitrogen	56	L _{pAeq}	11
General safety instructions	8	M	
Glass fuses	47	Mains frequency.....	18
Grinding cycles	41	Manufacturer's address	18
Grinding frequency	43	Materials	26
Grinding jar retaining device	32	Maximum relative humidity	13
Grinding jar volumes.....	26	Moderate or mild injury	7
Grinding time	42	N	
Grinding time	37	Name of machine model.....	26
Grinding with cooling	37	Noise values	11
Grinding with program	39	Notes on the Operating Manual.....	6
Grinding without cooling	37	Number of fuses.....	19
Grinding without program	38	O	
Grip	18	Opening gap	52
H		Operating elements and displays	29
Height.....	12	Operating elements and displays	27
Hood	48	Operating hours	46
I		Operating hours display	45
Insert the adapter for 4/2 x 5 ml grinding jar.....	35	Operating hours display	46
Inserting a 5ml grinding jar	35	Operating software display	46
Inserting and removing CryoMill special grinding jar	31	Operating the machine.....	26
Inserting reaction vials	36	Operating time	46
Inserting the cooling jacket seal	35	Optimal grinding jar filling	26
Inserting the cooling jacket sealing plug.....	34	Original parameters	48
Inserting the grinding jar	31	Outlet for gaseous nitrogen	24
Inserting the grinding jar	32	Oxygen deficiency.....	54
Inserting the grinding jar adapter	36	Oxygen enrichment.....	57
Installation height.....	14	P	
Installation of the machine	14	Packaging	13
		Part number	18

Power version	18	Serial number.....	18
Precooling.....	41	serious injury.....	7
Precooling.....	37	Service	51
Precooling with definable precooling time	41	Service Address.....	9
pressure relief	24	Setting grinding cycles	40
pressure relieve	23	Setting precooling	41
Programs	38	Setting the duration of intermediate cooling	42
property damage.....	7	Setting the grinding cycles	40
Protective equipment.....	11	Setting the grinding frequency	43
Pulling out the condensation collecting filter	16	Setting the grinding time	42
Q		Setting the precooling time	41
Quantities of sample material and feed sizes	48	Single grinding cycle	37
R		Software	46
Rated power	12	Special grinding jars.....	26
reaction vial.....	36	Starting the grinding process	43
Rear view	28	Starting the grinding process	44
Recommendations.....	54, 56, 57	Stopping the grinding process	44
Recovery of the samples	26	Summary table of device parts	28
Regulations for the place of installation.....	19	Supply line pressure	23
Remaining grinding time	48	Surrounding of the machine.....	58
Remove the grinding jar.....	33	T	
Removing the liquid nitrogen feed line	23	T 4 A.....	47
Removing the liquid nitrogen feed line	23	Target group	26
Removing the transport safeguard	14	Target group	8
Repairs.....	9	Technical data.....	11
Replacing the machine fuses	46	Temperature fluctuation and condensed water .	13
Required floor space.....	12	The grinding process	48
Rooms.....	58	threaded connector	23
S		Total operating time	46
Safety and occupational health instructions	52	Transport.....	13
Safety functions and fault display	50	Transport, scope of delivery, installation	13
Safety instructions on the handling of liquid nitrogen	54	Type plate	19
Safety warnings	7	type plate description	18
Seal.....	21	Type plate lettering	18
Securing the grinding jar.....	33	U	
Selection of a program.....	39	Use of the machine for the intended purpose....	26
Sequence of a single grinding cycle	38	Using the opening aid	34
Sequence of two grinding cycles	38		

V

vapour plume	14
Version of the operating software	46
Voluminous materials	26

W

Wear	51, 52
------------	--------

<i>Wearing parts</i>	51
-----------------------------------	----

Weight	12
--------------	----

Width	12
-------------	----

Working instructions	48
----------------------------	----

Working instructions	49
----------------------------	----

Y

Year of production	18
--------------------------	----

Mixer MILL

CryoMill

Certificate of CE-Conformity according to:

EC Mechanical Engineering Directive 2006/42/EC

Applied harmonized standards, in particular:
 DIN EN ISO 12100 Security of machines

EC Directive Electromagnetic Compatibility 2004/108/EC

Applied standards, in particular:
 EN 61000-3-2/-3 Electromagnetic compatibility (EMC)
 EN 61236 Electrical measuring, operating, controlling and laboratory equipment – EMC-requirements in conjunction with EN 61000
 EN 55011 Limit values and measuring procedures for noise suppression of industrial, scientific and medical high frequency devices

Additional applied standards, in particular

DIN EN 61010-1 Safety prescriptions concerning measuring-, operating-, controlling- and laboratory equipment

Authorized person for the compilation of technical documents:

J. Bunke (technical documentation)

The following records are held by Retsch GmbH in the form of Technical Documentation:

Detailed records of engineering development, construction plans, study (analysis) of the measures required for conformity assurance, analysis of the residual risks involved and operating instructions in due form according to the approved regulations for preparation of user information data.

The CE-conformity of the Retsch Mixer Mill Type CryoMill is assured herewith.

In case of a modification to the machine not previously agreed with us as well as the use of not licensed spare parts and accessories this certificate will lose its validity.

Retsch GmbH

Haan, january 2010

Dr. Stefan Mähler
 Manager technical services





Copyright

® Copyright by
Retsch GmbH
Haan, Retsch-Allee 1-5
D-42781 Haan
Federal Republic of Germany