



---

## Operating Instructions for Mortar Mill RM200

---

**Retsch**<sup>®</sup>

## **Notes on these operating instructions**

These operating instructions for the mortar mill, type RM200, give all the necessary information on the areas mentioned in the contents.

They instruct the target group(s) for each of the defined areas, in order to ensure safe handling of the RM200 when used for the intended purpose. Knowledge of the relevant section is an essential precondition for safe, proper use of the machine.

This technical documentation is a reference work and also a set of teaching instructions. The individual sections are complete in themselves.

These operating instructions do not include instructions for repairs. In case of possible defects or necessary repairs please contact your suppliers or Retsch GmbH direct:

**Retsch GmbH** [www.retsch.com](http://www.retsch.com)

<b>Notes on these operating instructions .....</b>	<b>2</b>
<b>Safety.....</b>	<b>4</b>
Safety instructions .....	4
Warning signs.....	5
Repairs .....	5
Confirmation .....	8
<b>Technical data .....</b>	<b>9</b>
Use according to the intended purpose .....	9
Emissions.....	9
Protective system: IP53 .....	9
Rated power: 230 Watt.....	9
Machine dimensions .....	9
Required floor space.....	9
<b>Transport and installation .....</b>	<b>10</b>
Packing .....	10
Transport .....	10
Intermediate storage.....	10
Conditions for the place of installation .....	11
Installation.....	11
Electrical connection .....	11
<b>Operation .....</b>	<b>12</b>
Operating elements and operation.....	12
Operating elements and their function .....	13
View of milling chamber.....	15
Installing / changing the milling fittings .....	16
Installing or changing the mortar .....	16
Installing or changing the pestle .....	17
Adjusting the pestle .....	18
Adjusting the pestle pressure .....	18
Adjusting the Scraper to the Mortar.....	19
Adjusting the contact pressure.....	20
Checking the scraper setting .....	21
Control milling operation.....	21
Adjusting the milling time .....	21
Stopping the milling process.....	23
Replacing the machine fuses.....	23
<b>Working instructions .....</b>	<b>24</b>
General.....	24
Materials.....	24
Crushing, mixing and milling of samples with grain size < 3mm .....	25
Crushing, mixing and milling materials of grain size > 3 mm .....	26
Security advice for handling liquid nitrogen .....	27
<b>Safety functions and fault displays.....</b>	<b>28</b>
Safety functions.....	28
<b>General .....</b>	<b>29</b>
Cleaning .....	30
Maintenance .....	30
Accessories RM200.....	30
Wear .....	31
Readjusting the lock pre-tensioning.....	31
Wearing parts.....	31
Checks.....	31
Copyright .....	31
Alterations .....	31
Summary of safety regulations for the RM200.....	32

## Safety

**Target group:** All persons concerned with the machine in any way.

The RM200 is a modern, highly efficient product of Retsch GmbH, corresponding to state of the art. If the machine is used according to the intended purpose with a knowledge of this technical documentation it is completely safe and reliable to operate.

### Safety instructions

As the operating authority it is your duty to ensure that all persons charged with working on the RM200:

- have read and understood all the instructions on safety,
- before beginning work know all the instructions and regulations for the target group relevant to their work,
- have access to the technical documentation for this machine at all times, without problems.
- New personnel should be familiarized with safe, proper handling of the machine before beginning work on the RM200, either by verbal instruction from a competent person or through this technical documentation.
- Improper operation can cause injury to persons or damage to the equipment. You are responsible for your own safety and that of your employees.
- Ensure that no unauthorised persons have access to the RM200.

For your own protection have your employees confirm that they have been instructed in operation of the RM200. The draft of a suitable form is given at the end of the section on safety.



We exclude any claims for damages of any kind for injury to persons and damage to equipment arising from non-observance of the following safety instructions.

### Warning signs

Warnings are given by the following signs:



**Injury to persons**



**Damage to equipment**



**Observe instructions for use**

### Repairs

These operating instructions do not include repair instructions. For your own safety repairs must be carried out only by Retsch GmbH or an authorised agent (service technicians).

### In this case please contact:

The Retsch agency in your country
Your supplier
Retsch GmbH directly

### Your service address:

_____
_____
_____
_____

### Safety instructions



We exclude any claims for damages of any kind for injury to persons and damage to equipment arising from non-observance of the following safety instructions.

### Use according to the intended purpose



Do not make any alterations to the machine and use only spare parts and accessories approved by Retsch. Otherwise the Declaration of Conformity with the European Directives by Retsch loses its validity. Furthermore this will result in the loss of any kind of guarantee claim.

### Packing



Please keep the packing material for the duration of the guarantee period since if there is a complaint and the machine is returned with inadequate packing your guarantee claim will be at risk.

### Transport



The RM200 must not be knocked, shaken or thrown during transport. Otherwise the electronic and mechanical components can become damaged.

### Temperature variations



If temperature variations are high (e.g. during air transport) the RM200 must be protected against condensed water. Otherwise the electronic components can become damaged.

### Supplied items



If the delivery is incomplete and / or there is transport damage you must inform the transporter and Retsch GmbH immediately (within 24 hrs). Later complaints may possibly be no longer considered.

### Conditions for the place of installation



If the ambient temperature drops below or exceeds these values the electronic and mechanical components can become damaged and performance data are changed to an unknown extent.



At higher atmospheric humidity the electronic and mechanical components can become damaged and performance data are changed to an unknown extent.

### Electrical connection



If the values on the type plate are not observed this can result in damage to the electrical and mechanical components.

### Installing or changing the mortar



Ensure that the mortar has engaged properly in the groove of the plate. Otherwise the mortar will be damaged when starting the machine.



When removing and opening heated milling cups protective gloves must be worn. Danger of burning the hands.

### Installing or changing the pestle



Make sure that the pestle is locked in position. Otherwise it may fall out when the lid is closed and damage the mortar.

### Adjusting the Scraper to the Mortar



The scraper can become sharp-edged as a result of sanding and wear during grinding operations. During cleaning in particular there is a risk of injury.

### Adjusting the scraper contact pressure



If the scraper pressure is set too high this causes rapid wear of the scraper and contamination of the material to be milled through the scraper material.



If the scraper pressure is set too high this increases the motor load and can cause triggering of the overload protection switch on the rear side of the machine.

### Adjusting the milling time



The milling operation can be started only if the lid is closed.



Please take all necessary measures, depending on the dangerousness of your sample, to prevent danger to persons.



Please note that the properties, and therefore the dangerousness of your sample, can change during the milling process.

#### General



Observe the relevant regulations and guidelines of your country for handling chemicals and hazardous materials. These should be applied when working with the RM200.

#### Materials



Milling of materials with a risk of fire or explosion in the RM200 is prohibited.



Please take the necessary measures, depending on the dangerousness of your sample, to avoid danger to persons.



Please note that the properties, and therefore the dangerousness of your sample, can change during the milling operation.

#### Crushing, mixing and milling of samples with grain size < 3mm



Do not charge the materials in batches. The mortar and pestle can become blocked, so that the motor is switched off by the controller to protect it from burning out.



Do not push material through the opening under the cover I with your fingers. Fingers can be squeezed.



Do not introduce any objects through the openings I + J. The mortar, pestle and scraper can become damaged and there is a possible danger of injury.

#### Crushing, mixing and milling materials of grain size > 3 mm



Do not add the material in batches. The mortar and pestle can become blocked, which leads to switching off of the machine.



Do not push material through the opening under the cover I with your fingers. Fingers can be squeezed.

#### Security advice for handling liquid nitrogen



Safety goggles and protective gloves should always be worn when handling liquid nitrogen. Liquid nitrogen has a temperature of  $-196\text{ }^{\circ}\text{C}$  and, if it comes into contact with the skin or eyes, may cause injuries similar to burns or frostbite.



A funnel must be used to fill cooling liquid into the RM 200. Otherwise the cover might be damaged.



Please observe the security advice of the liquid nitrogen supplier. Retsch excludes any liability claims which may result from the use of liquid nitrogen or similar substances.

#### Cleaning



Do not clean the RM200 with running water. Danger to life through current surge. Use only a cloth moistened with water. Cleaning agents and solvents must not be used – not for cleaning the milling tools either.

#### Accessories RM200



Do not carry out any modification of the machine and use only spare parts and accessories approved by Retsch. Otherwise the declared Conformity with the European Directives by Retsch will lose its validity. Furthermore this will lead to loss of any kind of guarantee claims.

#### Wearing parts



These operating instructions do not include repair instructions. For your own safety repairs should be carried out only by Retsch GmbH or an authorised agency and service technicians.

**Confirmation**

I have taken note of the section „Notes on these operating instructions” and the section on “Safety”.

---

Signature of operating authority

---

Signature of service technician



## Technical data

**Target group:** Operating authority, operators

**Machine type designation:** RM200

### Use according to the intended purpose

This machine is not designed as a production machine but as laboratory equipment, intended for an 8 hours single shift operation with 30% operating time.

The RM200 is suitable for dry and wet milling of soft, medium hard, hard, pasty and brittle materials, up to a hardness of 9 on the Mohs' scale.

Furthermore quantities of approx. 10 to 190 ml and a max. charging grain size of 8 mm can be ground and homogenised with the RM200, without manual use of force.

A final fineness of down to 0.01 mm (10 µm), and in individual cases even below this value, can be achieved with the RM200.



Do not make any alterations to the machine and use only spare parts and accessories approved by Retsch.

**Otherwise the Declaration of Conformity with the European Directives by Retsch loses its validity.**

**Furthermore this will result in the loss of any kind of guarantee claim.**

### Emissions

Noise characteristic values :

Noise measurement according to DIN 45635-031-01-KL3  
Intensity of sound  $L_{WA} = 85 \text{ dB(A)}$

Emission value related to workplace  $L_{pAeq} = 72 \text{ dB(A)}$

Operating conditions:

Material to be milled = quartz sand, grain size < 1 mm

**Protective system:** IP53

**Rated power:** 230 Watt

### Machine dimensions

Height: 480 mm up to approx. 550 mm with lid opened

Width: 400 mm

Depth : 370 mm up to approx. 510 mm with lid opened

Weight: approx. 24 kg without mortar and pestle

### Required floor space

400 mm x 400 mm plus space at the rear for the opened lid. No safety distance required.

## Transport and installation

**Target group:** Operating authority, transporter, operators

### Packing

Packing is adapted to the transport route and conforms to generally applicable packaging guidelines.



Please keep the packing material for the duration of the guarantee period since if there is a complaint and the machine is returned with inadequate packing your guarantee claim will be at risk.

### Transport



The RM200 must not be knocked, shaken or thrown during transport. Otherwise the electronic and mechanical components can become damaged.

### Temperature variations



If temperature variations are high (e.g. during air transport) the RM200 must be protected against condensed water. Otherwise the electronic components can become damaged.

### Intermediate storage

Ensure that the RM200 is also stored dry during intermediate storage.

## Conditions for the place of installation

### Ambient temperature:

5°C to 40°C



If the ambient temperature drops below or exceeds these values the electronic and mechanical components can become damaged and performance data are changed to an unknown extent.

### Atmospheric humidity:

Maximum relative humidity 80% at temperatures up to 31°C,

decreasing linearly down to 50% relative humidity at 40°C.



At higher atmospheric humidity the electronic and mechanical components can become damaged and performance data are changed to an unknown extent.

Installation height:

max. 2000 m above sea level

## **Installation**

Mount the RM200 only on a firm, stable laboratory bench since otherwise vibrations can be transmitted.

## **Electrical connection**

- Voltage and frequency for the RM200 are given on the type plate.
- Ensure that these values correspond to the available power supply system.
- Connect the RM200 to the power supply system using the supplied connection cable.
- Protection by external fusing is to be used when connecting the mains cable to the power supply, according to the regulations at the place of installation.
- The voltage supply to the RM200 must be provided with a fault-current circuit breaker (FI switch).



If the values on the type plate are not observed this can result in damage to the electrical and mechanical components.

# Operation

**Target group:** Operators

## Operating elements and operation

Diagram of operating elements:

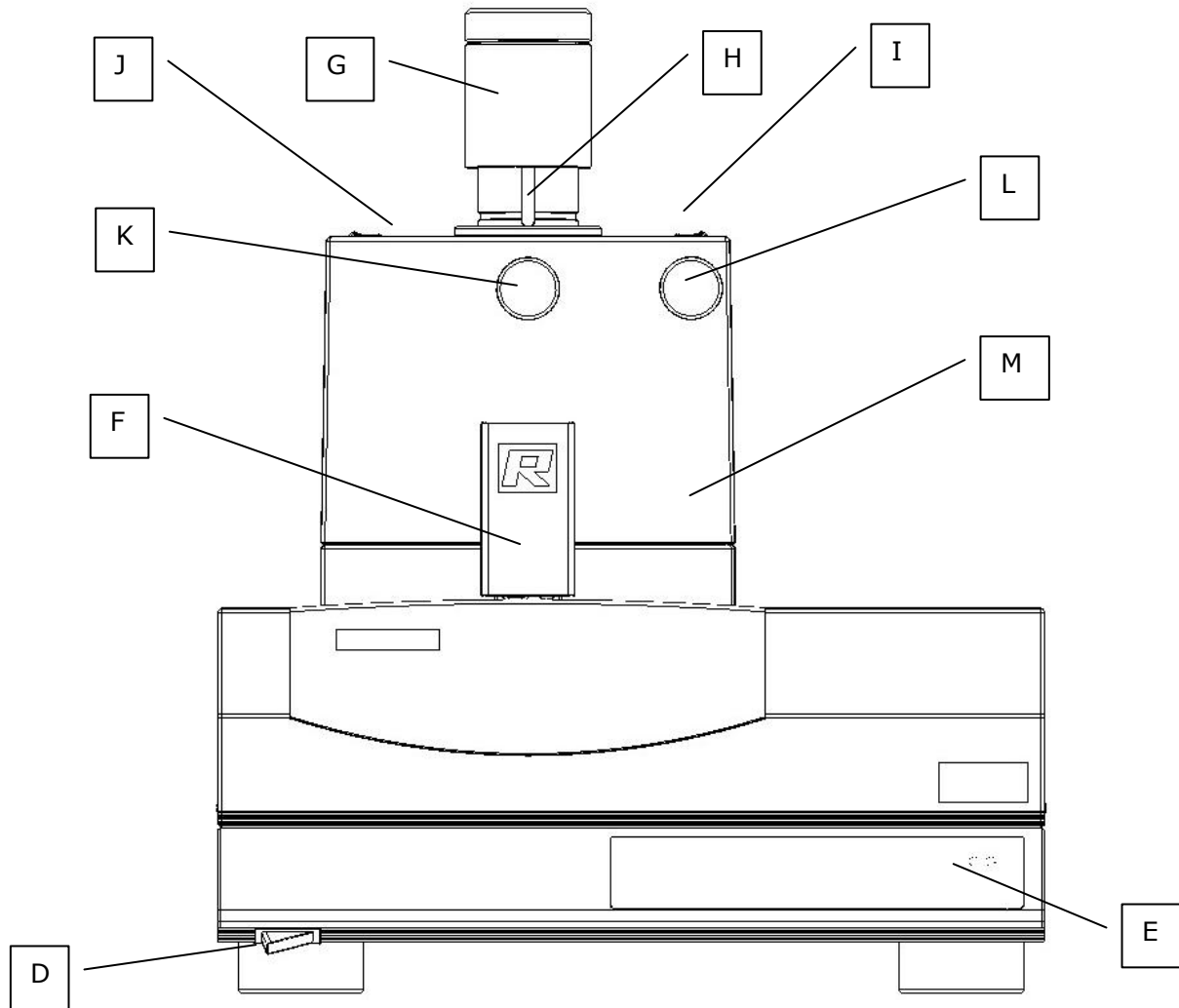

**Front view**

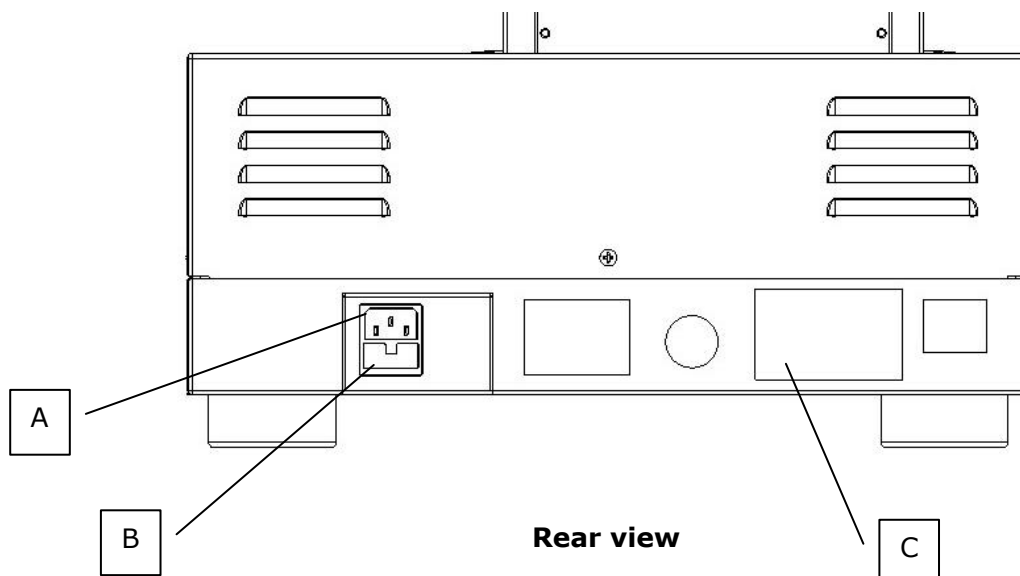

**Rear view**

## Operating elements and their function

### General plan

<b>Element</b>	<b>Description</b>	<b>Function</b>
<b>A</b>	Machine socket	Connection for power cable of machine
<b>B</b>	Fuse compartment	Takes two visible type fuses
<b>C</b>	Type plate	Information on the machine and connected loads
<b>D</b>	ON/OFF switch	For switching the RM200 on and off
<b>E</b>	Display and operating unit: For explanations see below	Time preselection and starting / stopping the machine
<b>F</b>	Closing grip	For opening and locking the milling chamber
<b>G</b>	Turning handle – pestle pressure adjustment	Turning alters the pestle contact pressure
<b>H</b>	Scale	Setting guide for pestle pressure
<b>I</b>	Filling opening	Sample material is filled here
<b>J</b>	Viewing window	Viewing possibility during the milling process, particularly for adjusting the scraper
<b>K</b>	Setting knob for scraper	Sets the contact pressure or gap of scraper
<b>L</b>	Pestle setting knob	For adjusting the pestle on the mortar wall
<b>M</b>	Hood	Closes the milling chamber

## Display and operating unit E

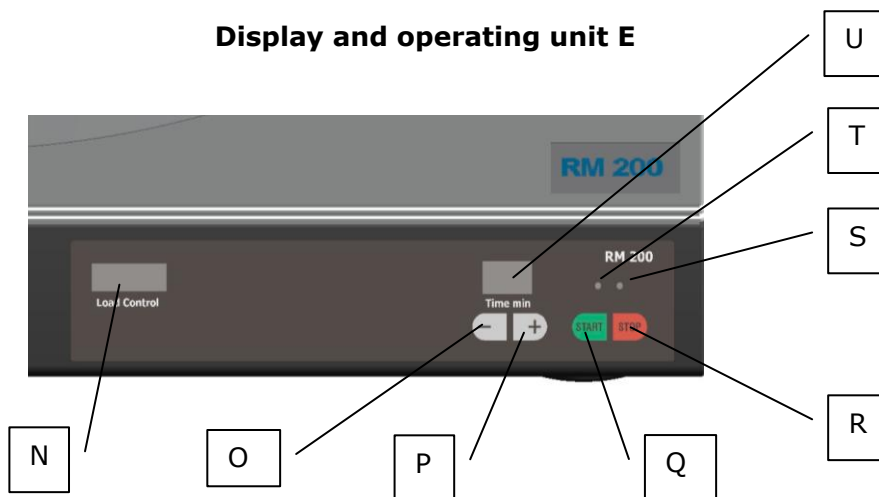

Element	Description	Function
<b>N</b>	Load Control – load indicator	Shows the actual load of the drive motor. Helps the user to avoid overloading and overload circuit breaking.
	Display = 1 to 4 green LEDs	Loading is OK
	Display = 4 green + 1 yellow LED	Slight overloading. Increasing the load can cause circuit breaking.
	Display = 4 green + 1 yellow + 1 red LED	Overloading! Continuous overloading with the red display switches off the control of the drive.
<b>O</b>	Time – minus button	In the adjusting mode and operating mode: decrease in the adjusted milling time by one minute. Continuous pressing switches off fast running.
<b>P</b>	Time – plus button	In the adjusting mode and operating mode: increase in the adjusted milling time by one minute. Continuous pressing causes fast running.
<b>Q</b>	Start button	Starts the milling operation
<b>R</b>	Stop button	Interrupts or ends the milling operation
<b>S</b>	Red LED	Indicates stand-by mode
<b>T</b>	Green LED	Indicates milling operation
<b>U</b>	Two digit display	Indicates the set milling time or, during operation, the milling time still remaining. Setting range: 1 to 99 minutes plus “- -” for continuous operation.

### View of milling chamber

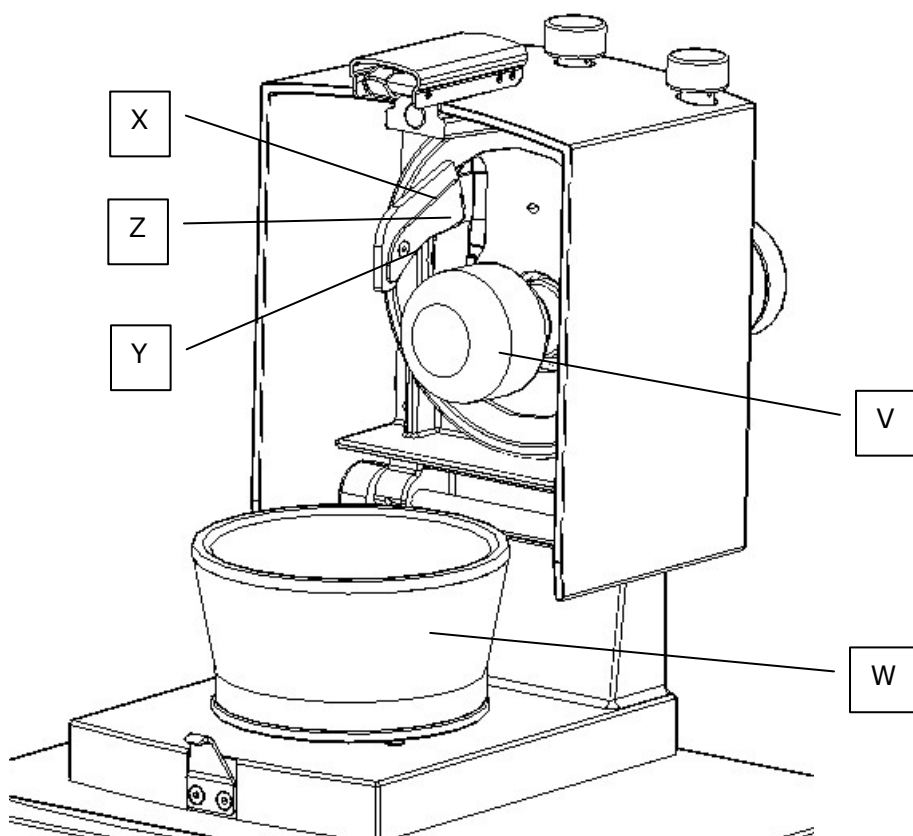

Element	Description	Function
<b>V</b>	Pestle	Crushes and mills the material
<b>W</b>	Mortar	Contains the material to be milled
<b>X</b>	Scraper	Mixes the milled material and scrapes off material adhering to the mortar
<b>Y</b>	Fixing screw for scraper	Holds the scraper with the screwed-on fixing clamp
<b>Z</b>	Fixing clamp for scraper	Clamps the scraper

### Installing / changing the milling fittings

If the RM200 has been ordered or supplied with milling fittings the mortar, pestle and scraper will have already been adjusted at the works.

If a new set of milling fittings is installed the pestle and scraper must be readjusted or positioned.

The mortar and pestle should always be made of the same material.

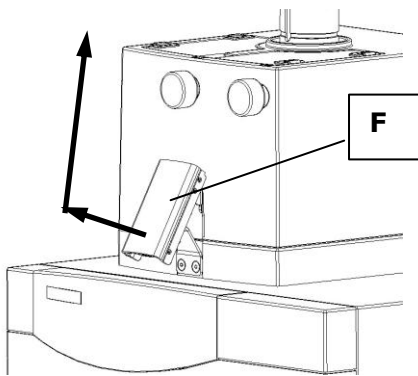

Fig. 1

### Installing or changing the mortar

- Hold the closing grip **F** at the bottom and pull. **Fig.1**

- Pull the hood upwards with the grip to open. **Fig.1**

- Remove mortar **W** **Fig.2**

- Place a new mortar in position and lock this in the groove of the plate **Tn** **Fig.3**

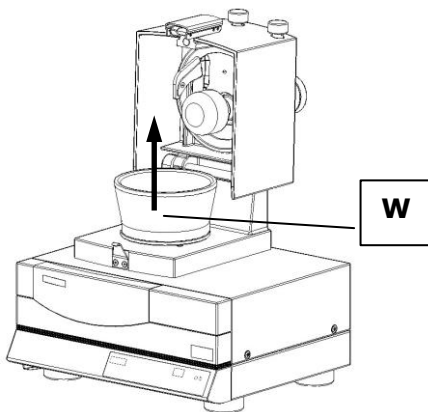

Fig. 2

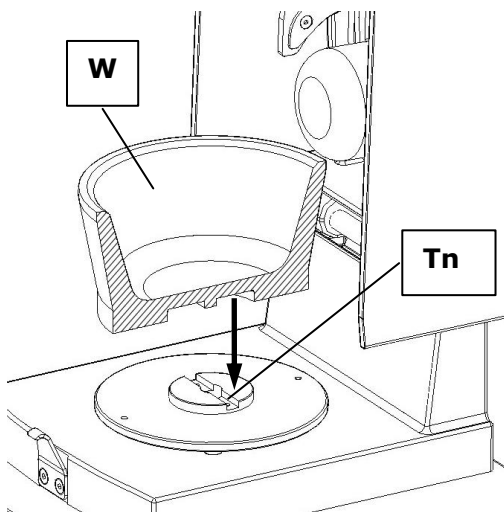

Fig. 3



Ensure that the mortar has engaged properly in the groove of the plate.

Otherwise the mortar will be damaged when starting the machine.



When removing and opening heated milling cups protective gloves must be worn.  
**Danger of burning the hands.**



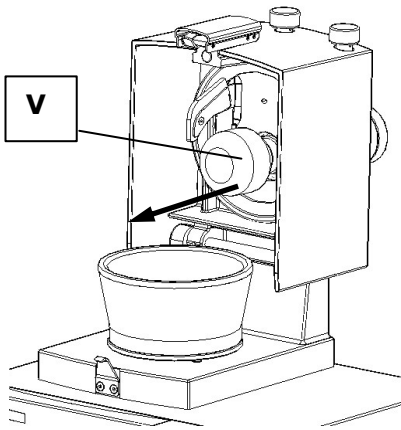

### Installing or changing the pestle

- Remove the pestle **V** horizontally from its holder while holding the hood firmly **Fig.4**
- Insert a new pestle into the holder until it noticeably engages.
- If the pestle does not engage turn this slightly and, if necessary, hold the holder firmly with the other hand so that the locking pins can engage at this position. **Fig.5**

To prevent contact corrosion, take the pestle out of the machine if the machine is idle for a long time.

**Fig. 4**

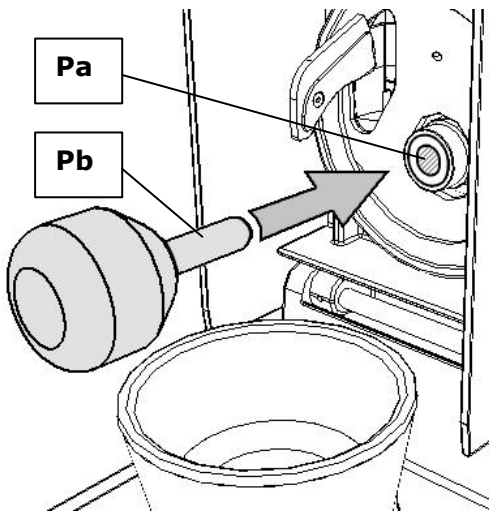

Ensure that the pestle bolt **Pb** is not contaminated. No dirt should get into the pestle holder **Pa Fig.4.1**

**Fig. 4.1**



Make sure that the pestle is locked in position. Otherwise it may fall out when the lid is closed and damage the mortar.

## Adjusting the pestle

**Fig.5**

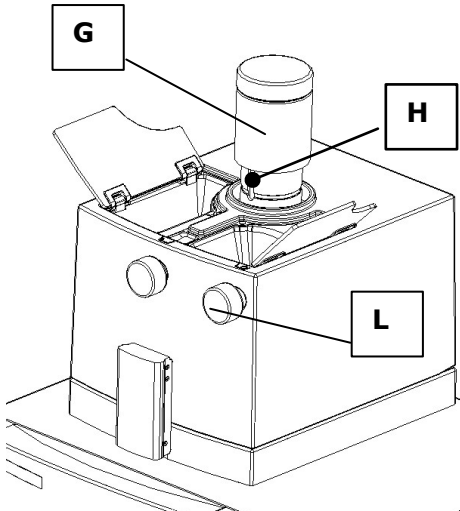

**Fig.5**

- The mortar **V** is installed
- The pestle **W** is installed and locked in position
- Close the lid **M** and press the closing grip **F** shut.
- Turn the rotary grip **G** anticlockwise and remove.
- Start the machine by switching on with the on/off switch **D** and pressing the start button **Q**
- Move the pestle forwards. To do this turn the pestle knob **L** to the left until this reaches the stop. The setting range is only a few millimeters for several rotations of the setting knob.
- Then move the pestle backwards again until resistance is felt. To do this turn the pestle knob **L** to the right. **Fig.6**

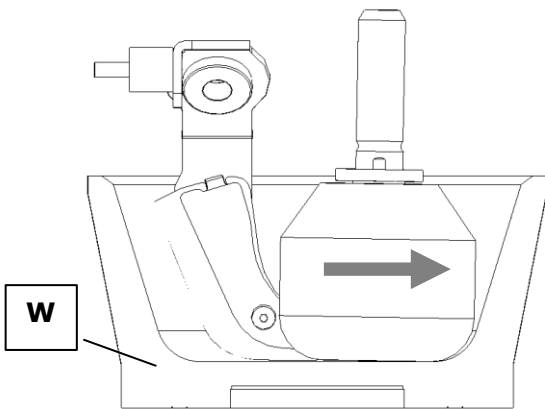

**Fig.6**

- In **Fig.6** the optimum setting has been reached since the lower rounded surface of the pestle is now running in the lower rounding of the mortar.
- As soon as the pestle shaft is pressed upwards during the setting process the pestle moves upwards on the mortar wall and setting is no longer optimum. In this case turn the pestle knob back slightly.

## Adjusting the pestle pressure

The correct pestle pressure should be determined by carrying out tests and depends on the material to be milled and the required degree of fineness.

### Increasing the pressure: Fig.5

- Turn the sleeve **G** clockwise
- This increases the pressing force downwards **Fig.7**
- The value can be read off on scale **H**

### Reducing the pressure: Fig.5

- Turn the sleeve **G** anticlockwise
- The values on scale **H** are reduced

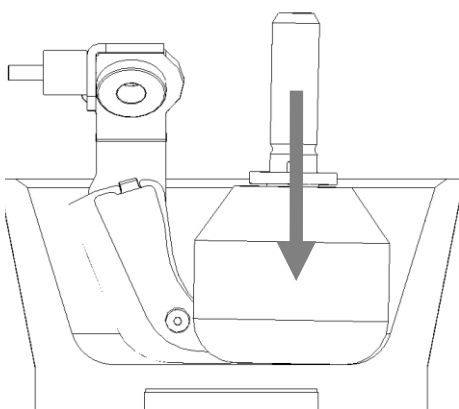

**Fig.7**

The values indicated on scale **H** are only for use as a guide during setting. They can be used as an aid in reproducing the conditions. However, no mathematical conclusion regarding the contact pressure is possible since this depends on the material to be milled.

## Adjusting the Scraper to the Mortar

When the machine is delivered or when a scraper is re-ordered, it may be necessary to regrind scraper **A**. This depends on the shape of the mortar **M** or the wear on it.

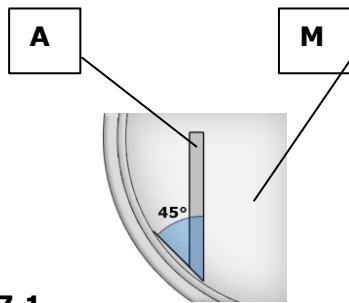

Fig.7.1

### Fig.7.1

Regrinding is necessary in the following cases:

- when the machine is supplied without a mortar or grinding set
- when a scraper or mortar is reordered

The scraper was chamfered slightly in the factory in order to make regrinding easier. The grinding angle should be 45° and depend on the shape of the mortar.

### Fig.7.1 und Fig.7.2

You can use a belt sander, a grindstone or sandpaper to do the grinding.

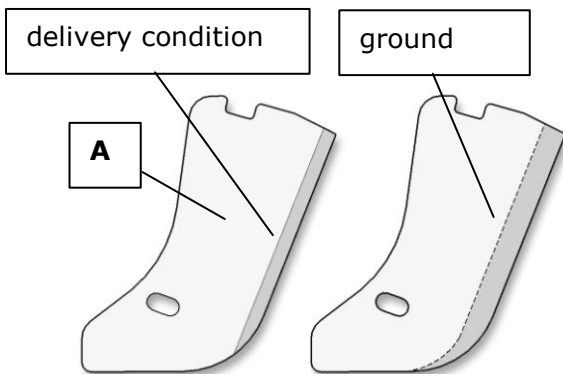

Fig.7.2



The scraper can become sharp-edged as a result of sanding and wear during grinding operations. During cleaning in particular there is a risk of injury.

## Installing / replacing the scraper

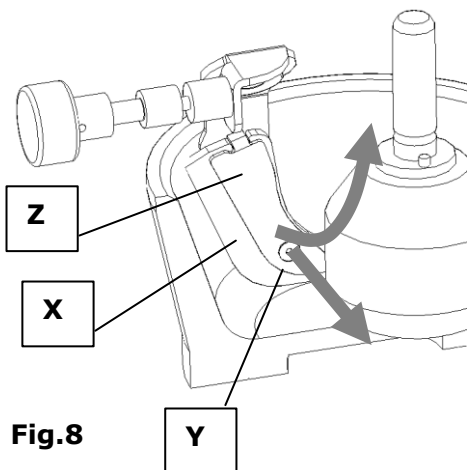
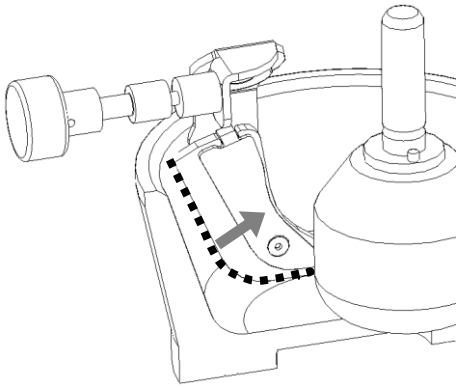

Fig.8

- Open the cover **M**.
- Flip the cover to the back.
- Loosen the screw **Y** with the supplied screwdriver.
- Remove the retaining screw **Y**.
- Swing out the mounting bracket.
- Remove the scraper.
- Insert the new scraper.
- Hook the mounting bracket **Z** again.
- Turn the screw **Y** loose.
- The scraper can be adjusted by its slot slightly forward or backward.
- Slide the scraper backwards.
- Tighten the screw. Fig.9
- Close the cover.
- Check visually or by sample material if the scraper is applied accurate on the mortar.

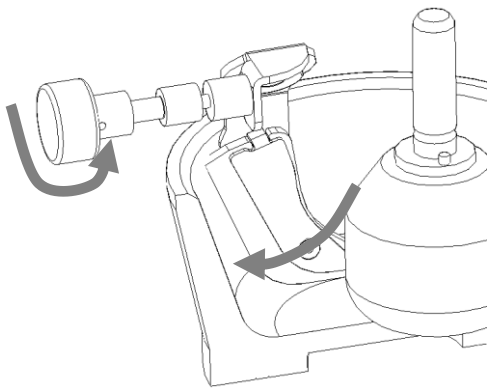

**Fig.9**

- See also below: "control the scraper adjustment"

If the scraper is not completely touching the bottom of the mortar and the mortar inner wall (dotted line in Fig.8), it must be adjusted again:

- Loosen the screw **Y** again.
- Move the scraper.
- Tighten the screw.
- Check again, visually or with sample material if the scraper is applied accurate on the mortar.



**Fig.10**

---

### Adjusting the contact pressure

The required contact pressure of the scraper **X** must be determined empirically, depending on the material to be milled and the required degree of fineness.

#### Increasing the contact pressure: Fig.10

- Turn the scraper adjusting knob **K** anticlockwise

#### Reducing the contact pressure:

- Turn the scraper adjusting knob **K** clockwise



If the scraper pressure is set too high this causes rapid wear of the scraper and contamination of the material to be milled through the scraper material.



If the scraper pressure is set too high this increases the motor load and can cause triggering of the overload protection switch on the rear side of the machine.

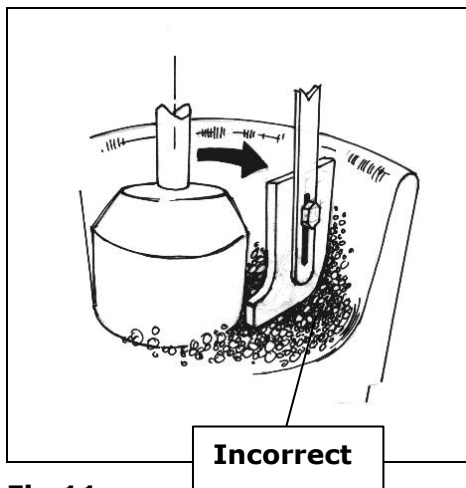

**Fig.11**

### Checking the scraper setting

The scraper fulfils its function only if adjustment of the contact pressure and contact with the bottom of the mortar is optimum.

This can best be assessed by carrying out a neutral milling operation.

### Control milling operation

We recommend the following mixture as neutral milling material:

- e.g. 4 – 5 teaspoons of powder sugar
- 5 – 10 ml water

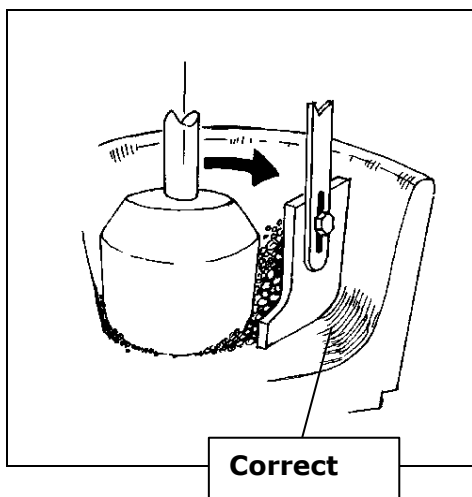

**Fig.12**

- Close the lid with the mortar empty and press the closing grip shut.
- Turn the rotary grip **G** to setting „0“ of scale **H**
- Switch on the machine, start the operation by pressing the start button **Q**.
- Add the powder sugar through the right-hand window opening **I** of the lid, then pour in the water.

A pasty mixture is formed which does not adhere to the inside wall or to the bottom of the mortar if the scraper has been adjusted correctly.

See **Fig.11 and 12**

For visually checking look through the left-hand window **J**

### Adjusting the milling time

The milling time can be adjusted with the display and operating unit **E**

- Switch on the RM200 with switch **D**. **Fig.13**

### Preselecting the time

- Set the required milling time with the + / - buttons **O** and **P** **Fig.14**
- Short pressing of the + or - button changes the milling time by one minute in each case. With longer pressing the display runs through continuously.

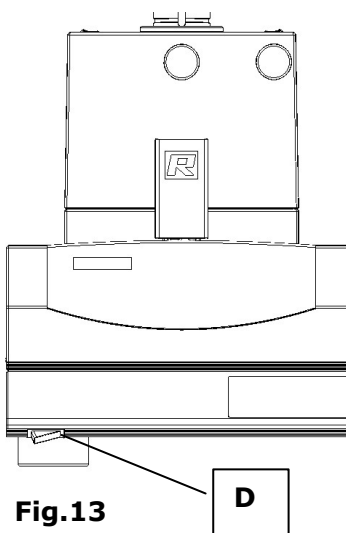

**Fig.13**

If 99 is exceeded the display **U** shows two minus signs: -- This setting means continuous operation

without automatic switching off.

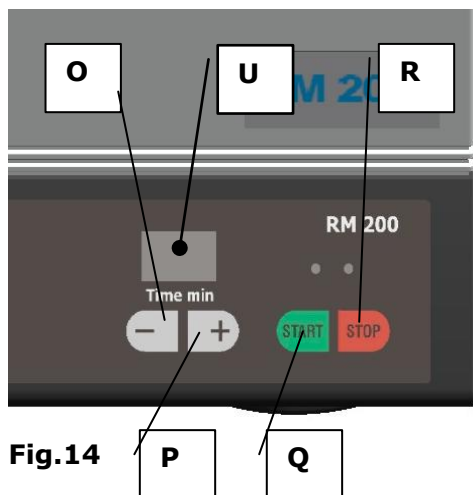

Fig.14

### Starting the milling operation

- When the lid is closed:
- The milling operation is started with the start button **Q**. **Fig.13**
  - The milling time is recorded and the remaining milling time is indicated in display **U**.



The milling operation can be started only if the lid is closed.



Please take all necessary measures, depending on the dangerousness of your sample, to prevent danger to persons.



Please note that the properties, and therefore the dangerousness of your sample, can change during the milling process.

## Stopping the milling process

- Press the stop button **R** . **Fig.14**

Pressing the button once interrupts the milling operation in order that, for example, the material to be milled can be assessed. The remaining milling time is still visible in the display **U** . By repressing the start button the mill continues to run until the milling time has completely elapsed.

- Pressing the stop button twice stops the milling operation and the machine is then in the stand-by mode.
- By pressing the start button the display is reactivated and the milling time is reset to the last start value.

During the milling operation the time can be adjusted by pressing the + or – button.

The milling operation is automatically ended after the milling time has elapsed. The display is reset to the last started value.

## Replacing the machine fuses

The following visible type fuses are required for the RM200:

- 2 MT 3.15 A for 230V machine
- 2 MT 6.30 A for 100V to 120V machine

### Replacing the fuses Fig.15

- Unplug mains plug from the machine socket **A**
- Unlock and remove the fuse compartment **B** by pressing the locking device upwards.
- Replace the fuses
- Insert fuse holder **B**

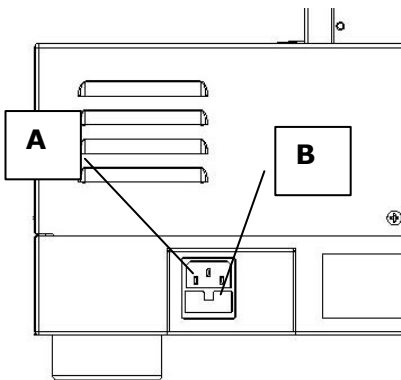

**Fig.15**

# Working instructions

**Target group:** Laboratory assistant

## General

The RM200 mills through pressure and friction. This combination of two loading mechanisms enables both soft and hard, brittle material to be crushed, milled and mixed in this machine. Both dry and wet milling operations can be carried out in the RM200.

Materials which are difficult to mill can be made brittle by cooling, or can be prepared by mixing with milling auxiliary agents. Please ask your Retsch contact for advice on this.



Observe the relevant regulations and guidelines of your country for handling chemicals and hazardous materials.

These should be applied when working with the RM200.

You should also take into consideration the health protection regulations concerned with the function of health-hazardous dusts, e.g.

- BGR 217\* „Handling mineral dust“
- BGI 504-1-1\* and BGI 504-1-4\* „Dust exposure – industrial preventive medicine“
- BGR 120\* „Directives for laboratories“

(\* German federal laws)

## Materials

The RM200 is suitable for dry and wet milling of materials of all kinds, with the following possible properties:

- soft
- medium hard
- hard
- pasty or
- brittle.

The maximum hardness of the materials can be up to 9 on the Mohs' scale.



Milling of materials with a risk of fire or explosion in the RM200 is prohibited.



Please take the necessary measures, depending on the dangerousness of your sample, to avoid danger to persons.





Please note that the properties, and therefore the dangerousness of your sample, can change during the milling operation.

Quantities from approx. 10 to 190 ml and a max. charging grain size of 8 mm can be milled and homogenised with the RM200, without any manual use of force.

The ideal filling quantity depends on the sample quantity and the properties of the materials to be milled.

Selection of the milling tools depends on the sample material and the subsequent analysis.

Different milling tools have different characteristics, e.g. the materials contained in them, hardness or abrasion resistance.

For reliable analytical results you should select the milling tools in such a way that the milling process is neutral with regard to contamination.

Please ask for advice in case of doubt.

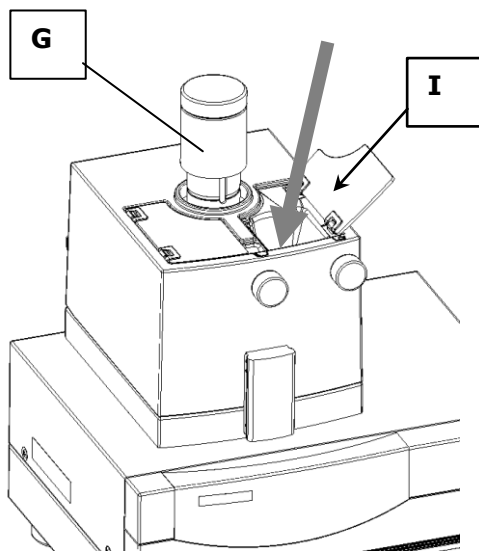

Fig.16

### Crushing, mixing and milling of samples with grain size < 3mm

Connect the RM200 to the power supply, switch on and start.

The sample is slowly added to the rotating mortar through the filling opening **I**. For this purpose the right-hand Plexiglass cover **I** is opened. **Fig.16**

The pestle, which is offset in relation to the centre of the mortar, presses on the bottom of the mortar and the material to be milled through spring tension and its own weight.

Through the resulting friction the pestle is also rotated with the mortar and this crushes the material to be milled through pressure and friction. The pressure can be varied by means of the rotary grip **G** **Fig.16**

The scraper ensures that the sample material is scraped off the inside wall of the mortar, recirculated and refed to the milling gap between the pestle and mortar.

This forced feeding of the material ensures that the complete sample quantity is well mixed and that every particle is continuously fed to the milling and pulverizing process.



Fig.17

**N**

### Load Control and safety switch off

The load indicator "Load Control" **N** **Fig.17** and **18** serves as a guide for the user. It indicates loading of the drive motor in 6 stages. At low to full load 1 to 4 green LEDs light up. At slight overloading a yellow LED lights up in addition.

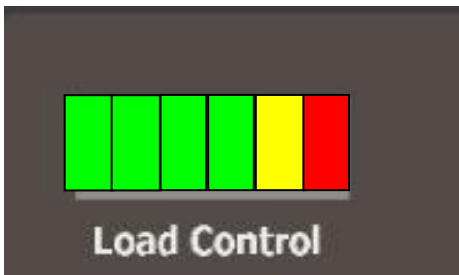

Fig.18

In the case of definite overloading the red LED lights up additionally and thus signals that the machine will soon be switched off. This switch-off takes place when overloading for 90 secs is measured within a short period.

The machine is also switched off if it comes to a standstill for 10 seconds through blockage.



Do not charge the materials in batches.

The mortar and pestle can become blocked, so that the motor is switched off by the controller to protect it from burning out.



Do not push material through the opening under the cover **I** with your fingers.

**Fingers can be squeezed.**



Do not introduce any objects through the openings **I + J**. The mortar, pestle and scraper can become damaged and there is a possible danger of injury.

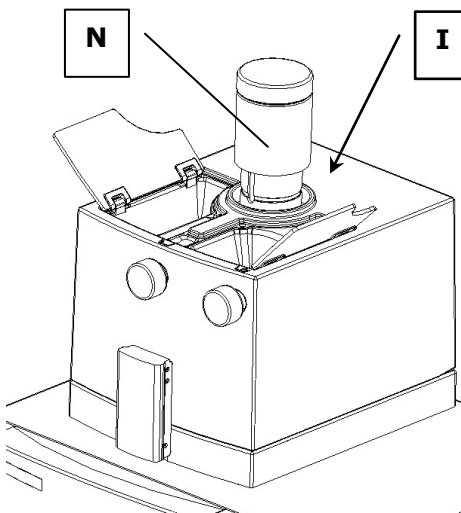

Fig. 19

### Crushing, mixing and milling materials of grain size > 3 mm

Close the RM200 and switch on.

#### Precrushing: Fig.14

- Loosen the rotary grip for adjusting the pestle **G** down to scale setting "0"

The pressure of the pestle on the mortar is now minimum.

- Start the milling operation.
- Add the material to be milled slowly through the charging opening **I**

#### Fine milling: Fig.14

- Increase the pestle pretension again by turning the rotary grip **G** clockwise.



Do not add the material in batches.  
The mortar and pestle can become blocked, which leads to switching off of the machine.



Do not push material through the opening under the cover **I** with your fingers.  
**Fingers can be squeezed.**

### Security advice for handling liquid nitrogen



**Safety goggles and protective gloves should always be worn when handling liquid nitrogen.**  
Liquid nitrogen has a temperature of  $-196\text{ °C}$  and, if it comes into contact with the skin or eyes, may cause injuries similar to burns or frostbite.

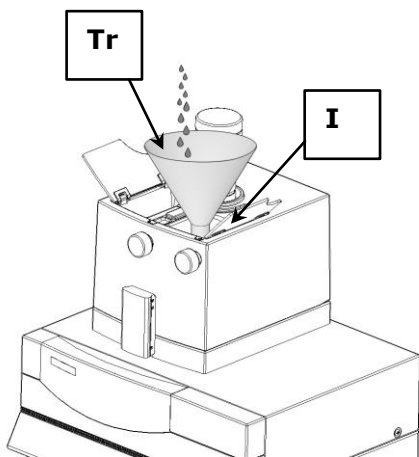

**Fig.19.1**

Safety goggles also give protection against eye injuries cause by flying fragments of glass from glass containers, which may burst owing to cold tensions.

The RM 200 can also be used for cryogenic grinding. Please note that the cooling liquid must be filled in via a funnel to avoid damages of the cover of the RM 200.

Place a standard funnel **Tr** into the feed opening **I**. Pour liquid nitrogen into the funnel and take care that the liquid does not get in contact with the cover.  
**Fig. 19.1**



A funnel must be used to fill cooling liquid into the RM 200. Otherwise the cover might be damaged.



**Please observe the security advice of the liquid nitrogen supplier.**  
Retsch excludes any liability claims which may result from the use of liquid nitrogen or similar substances.

# Safety functions and fault displays

## Safety functions

### F1 - Overloading

F1

03

In order to prevent overloading of the drive motor and resulting danger to the operator the RM200 is provided with a load control.

This continuously measures the actual motor load and indicates this in the load control display. In case of overloading the load control switches off the machine in good time and guarantees a cooling time. This is indicated to the operator by the alternately flashing display F1 and the remaining cooling time, e.g. 03 = 3 minutes.

After the cooling time has elapsed it is only necessary to switch the machine off and on again to operate it normally again.

### F4 – Hood open

F4

If the hood is open the drive should not run. This serves to protect the operator from injury. If the hood is opened while the machine is running the drive is immediately switched off by the controller and "F4" appears in the display. If the start button is pressed with the hood open in order to start the milling operation F4 is also displayed and the drive is not started.

This signal can be deleted by pressing the stop button.

### F5 –Keyboard control

F5

If one or more buttons are accidentally pressed for longer than 15 seconds the drive is switched off by the controller and F5 is displayed.

This function is intended to prevent unintentional faulty operation if an object accidentally presses on the keyboard.

In order to delete this fault signal switch the machine off and on again once.

### F6 – Switch control for hood switch

F6

If the switch which controls hood opening has a lead defect this is recognised by the controller and causes the machine to be switched off. "F6" appears in the display. To remedy this fault repairs by an authorised Retsch service technician are required.

## General

### Accessories / milling tools

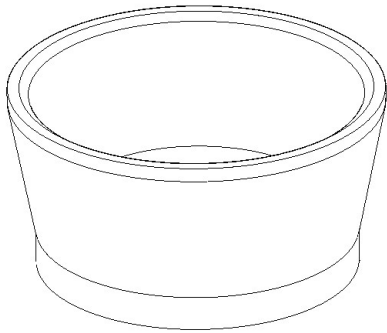

**Fig.20**

#### **Mortar Fig.20**

- Mortar of special steel
- Mortar of stainless steel
- Mortar of agate
- Mortar of sintered corundum
- Mortar of zirconium oxide
- Mortar of hard porcelain
- Mortar of tungsten carbide

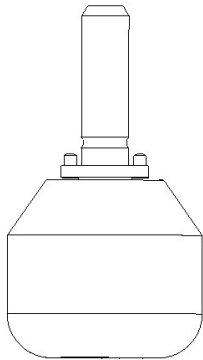

**Fig.21**

#### **Pestle Fig.21**

- Pestle of tungsten carbide
- Pestle of special steel
- Pestle of stainless steel
- Pestle of agate
- Pestle of sintered corundum
- Pestle of zirconium oxide
- Pestle of hard porcelain

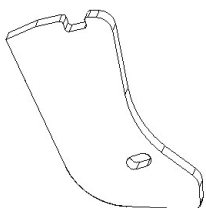

**Fig.22**

#### **Scraper Fig.22**

- Scraper of PUR (abrasion resistant, rubber type material)
- Scraper of beech wood
- Scraper of PTFE (Teflon)

## Cleaning



Do not clean the RM200 with running water.

### **Danger to life through current surge**

Use only a cloth moistened with water. Cleaning agents and solvents must not be used – not for cleaning the milling tools either.

## Maintenance

The RM200 is maintenance free. When used properly no maintenance and adjusting work need be carried out.

## Accessories RM200

<b>Designation</b>	<b>Material</b>	<b>Article No.</b>
Mortar RM200/100	Special steel	02.460.0018
Mortar RM200/100	Stainless steel	02.460.0057
Mortar RM200/100	Tungsten carbide	02.460.0021
Mortar RM200/100	Agate	02.460.0098
Mortar RM200/100	Sintered corundum	02.460.0017
Mortar RM200/100	Zirconium oxide	02.460.0086
Mortar RM200/100	Hard porcelain	02.460.0016
Pestle RM200	Special steel	02.461.0112
Pestle RM200	Stainless steel	02.461.0113
Pestle RM200	Tungsten carbide	02.461.0114
Pestle RM200	Agate	02.461.0115
Pestle RM200	Sintered corundum	02.461.0116
Pestle RM200	Zirconium oxide	02.461.0117
Pestle RM200	Hard porcelain	02.461.0118
Scraper	PTFE	03.008.0022
Scraper	Beech wood	03.008.0023
Scraper	PU	03.862.0011



Do not carry out any modification of the machine and use only spare parts and accessories approved by Retsch.

**Otherwise the declared Conformity with the European Directives by Retsch will lose its validity. Furthermore this will lead to loss of any kind of guarantee claims.**

## Wear

The scraper and milling tools can wear, depending on the frequency of milling operations and the material to be milled. The scraper should be regularly checked for wear and replaced if necessary. The scraper must be reset before the metal components come into contact with the mortar.

## Readjusting the lock pre-tensioning

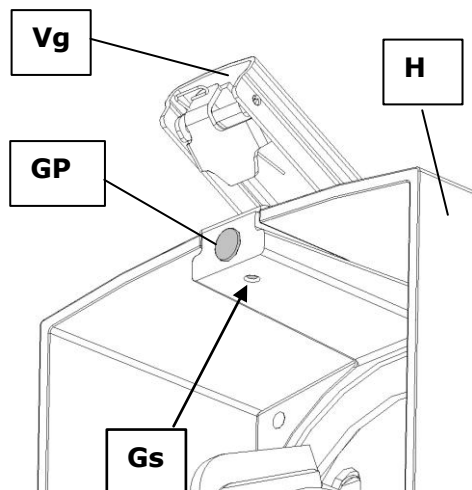

The lock tension in the lock handle **Vg** can be influenced by adjusting the rubber buffer **GP**.

Open the hood **H** and loosen the setscrew **Gs**.

### Increasing the lock tension:

Turn the rubber buffer GP in an anti-clockwise direction

### Reducing the lock tension:

Turn the rubber buffer GP in a clockwise direction

## Wearing parts



These operating instructions do not include repair instructions. For your own safety repairs should be carried out only by Retsch GmbH or an authorised agency and service technicians.

## Checks

The function of the hood switch must be checked regularly:

- Switch on the machine with switch **D**
- Start the milling operation with start button **Q**
- Open the closing grip **F** and lift up the hood
- If there is an opening gap of only a few cm the machine is switched off and **F4** appears in the display.
- Delete **F4** with stop button **R**

If switching off does not take place the RM200 must be checked immediately by Retsch service.

## Copyright

Distribution or duplication of this documentation, using and passing on the contents is allowed only with the express permission of Retsch GmbH.

Anyone violating is liable to pay damages.

## Alterations

Subject to technical alterations without notice.

## Summary of safety regulations for the RM200

Process	Action	Danger
<b>Safety</b>	Injury to persons and damage to the machine caused through non-observance of the safety instructions	Claims for damages in any form are excluded
<b>Transport</b>	Do not knock, vibrate or throw the RM200 during transport	Electronic and mechanical components can be damaged
	Keep the packing material for the duration of the guarantee	Complaint and return of the equipment in inadequate packing material puts your guarantee claim at risk
<b>Temperature variations</b>	If there are temperature variations protect the RM200 from condensed water	Electronic components can be damaged
<b>Supplied items</b>	If the delivery is incomplete and/or there is transport damage you must inform the transporter and Retsch GmbH immediately (within 24 hrs).	Later complaints may possibly not be considered.
<b>Ambient temperature</b>	Drops below 5°C Exceeds 40°C	Electronic and mechanical components may be damaged. Performance data are changed to an unknown extent.
<b>Atmospheric humidity</b>	Exceeds 80% at temperatures up to 31°C	Electronic and mechanical components can be damaged. Performance data are changed to an unknown extent.
<b>Electrical connection</b>	Power supply does not agree with the values on the type plate Fault current protective switch must be provided in the power supply	Mechanical and electronic components can be damaged. Prevents current surge if there is an electrical defect in the machine.
<b>Installing the mortar</b>	Ensure that the mortar is properly engaged in the plate slot.	Mortar and pestle can be damaged.
<b>Installing the pestle</b>	Ensure that the pestle engages properly.	The pestle can fall out when closing the hood and damage the mortar.
<b>Scraper pressure</b>	Set too high	Rapid wear to be expected. Contaminates the sample to a greater extent than expected. Increases the motor load and can cause switching off through overloading.
<b>Crushing Mixing Milling</b>	Do not push sample material into the opening with your fingers. Do not push sample material in using objects.  Do not add sample material in batches.	Fingers can be squeezed. Mortar, pestle and scraper can be damaged, danger of injury. Mortar and pestle can become blocked.
<b>Checks</b>	Check hood switch regularly	Danger of injury if there is a defect and the machine is open in operation.
<b>Cleaning</b>	Do not clean with running water.	<b>Danger to life through current surge</b>



# MORTAR GRINDER

## RM 200

Certificate of CE-Conformity according to:

### EC Mechanical Engineering Directive 2006/42/EC

Applied harmonized standards, in particular:  
DIN EN ISO 12100 Security of machines

### EC Directive Electromagnetic Compatibility 2004/108/EC

Applied standards, in particular:

EN 61000-3-2/-3	Electromagnetic compatibility (EMC)
EN 61236	Electrical measuring, operating, controlling and laboratory equipment – EMC-requirements in conjunction with EN 61000
EN 55011	Limit values and measuring procedures for noise suppression of industrial, scientific and medical high frequency devices

### Additional applied standards, in particular

DIN EN 61010	Safety prescriptions concerning measuring-, operating-, controlling- and laboratory equipment
--------------	---

### Authorized person for the compilation of technical documents:

J. Bunke (technical documentation)

### The following records are held by Retsch GmbH in the form of Technical Documentation:

Detailed records of engineering development, construction plans, study (analysis) of the measures required for conformity assurance, analysis of the residual risks involved and operating instructions in due form according to the approved regulations for preparation of user information data.

The CE-conformity of the Retsch Mortar Grinder Type RM 200 is assured herewith.

**In case of a modification to the machine not previously agreed with us as well as the use of not licensed spare parts and accessories this certificate will lose its validity.**

Retsch GmbH

Haan, January 2010

Dr. Stefan Mähler  
Manager technical services









**Copyright**

© Copyright by  
Retsch GmbH  
Haan, Retsch-Allee 1-5  
D-42781 Haan  
Federal Republic of Germany