

Manual
Knife Mill Grindomix GM200



Translation



Copyright

© Copyright by
Retsch GmbH
Haan, Retsch-Allee 1-5
D-42781 Haan
Federal Republic of Germany

1	Notes on the Operating Manual	5
1.1	Explanations of the safety warnings	6
1.2	General safety instructions	7
1.3	Repairs.....	8
2	Confirmation	9
3	Transport, scope of delivery, installation	10
3.1	Packaging	10
3.2	Transport.....	10
3.3	Temperature fluctuations and condensed water	10
3.4	Conditions for the place of installation	10
3.5	Installation of the machine	10
3.6	Electrical connection	10
3.7	Type plate description.....	11
4	Technical data	12
4.1	Use of the machine for the intended purpose.....	12
4.2	Working instructions	13
4.3	Protective equipment	13
4.4	Drive output.....	13
4.5	Rated power	13
4.6	Motor rotation speed.....	13
4.7	Rated voltage.....	13
4.8	Emissions.....	14
4.8.1	Noise measurement Example 1:.....	14
4.8.2	Noise measurement Example 2:.....	14
4.9	Degree of protection	14
4.10	Dimensions and weight.....	14
4.11	Required floor space.....	15
5	Operating the machine	16
5.1	Views of the Instrument	16
5.2	Overview table of the parts of the device	18
5.3	Overview Table of the Operating Elements and the Display.....	19
5.4	Operating the Device	20
5.5	Switching On and Off.....	20
5.6	Opening and closing of the grinding chamber	21
5.7	Inserting the grinding jar	21
5.8	Use of grinding jugs depending on different materials	21
5.8.1	Grinding jars – plastic jugs (PP)	22
5.8.2	Grinding jars – glass jugs (borosilicate glass 3.3)	22

5.8.3	Grinding jars – stainless steel jugs	22
5.9	Lid and jug combinations	22
5.9.1	Lid 1000ml	23
5.9.2	Lid 500ml	24
5.9.3	Gravitation lid	24
5.10	Filling the vessel	25
5.10.1	Filling – within the device	25
5.10.2	Filling – outside the device	26
5.11	Setting the grinding time	27
5.12	Setting the Speed	28
5.13	Switching on interval or continuous mode	28
5.14	Reverse grinding.....	29
5.15	Store functions	30
5.15.1	Saving programs.....	30
5.15.2	Starting a saved program	30
5.16	Start – Pause – Stop.....	30
5.16.1	Pause function	30
5.16.2	Premature termination of grinding	30
5.17	Resetting the overload protection	30
6	Cleaning and service	31
6.1	Cleaning the Grinding Tools	32
6.2	Check the sealing lip.....	33
7	Fault messages.....	34
8	Disposal.....	35
9	Index	36
Appendix following pages	

1 Notes on the Operating Manual

This operating manual is a technical guide on how to operate the device safely and it contains all the information required for the areas specified in the table of contents. This technical documentation is a reference and instruction manual. The individual chapters are complete in themselves.

Familiarity (of the respective target groups defined according to area) with the relevant chapters is a precondition for the safe and appropriate use of the device.

This operating manual does not contain any repair instructions. If faults arise or repairs are necessary, please contact your supplier or get in touch with Retsch GmbH directly.

Application technology information relating to samples to be processed is not included but can be read on the Internet on the respective device's page at www.retsch.com.

Changes

Subject to technical changes.

Copyright

Disclosure or reproduction of this documentation, use and disclosure of its contents are only permitted with the express permission of Retsch GmbH.

Infringements will result in damage compensation liability.

1.1 Explanations of the safety warnings

In this Operating Manual we give you the following safety warnings

Serious injury may result from failing to heed these safety warnings. We give you the following warnings and corresponding content.

 **WARNING**

Type of danger / personal injury

Source of danger

- Possible consequences if the dangers are not observed.
 - **Instructions on how the dangers are to be avoided.**
-

We also use the following signal word box in the text or in the instructions on action to be taken:

 **WARNING**

Moderate or mild injury may result from failing to heed these safety warnings. We give you the following warnings and corresponding content.

 **CAUTION**

Type of danger / personal injury

Source of danger

- Possible consequences if the dangers are not observed.
 - **Instructions on how the dangers are to be avoided.**
-

We also use the following signal word box in the text or in the instructions on action to be taken:

 **CAUTION**

In the event of possible **property damage** we inform you with the word “Instructions” and the corresponding content.

NOTICE

Nature of the property damage

Source of property damage

- Possible consequences if the instructions are not observed.
 - **Instructions on how the dangers are to be avoided.**
-

We also use the following signal word in the text or in the instructions on action to be taken:

NOTICE

1.2 General safety instructions

 **CAUTION**

Read the Operating Manual

Non-observance of these operating instructions

- The non-observance of these operating instructions can result in personal injuries.
- **Read the operating manual before using the device.**
- **We use the adjacent symbol to draw attention to the necessity of knowing the contents of this operating manual.**



Target group : All persons concerned with the machine in any form

This machine is a modern, high performance product from Retsch GmbH and complies with the state of the art. Operational safety is given if the machine is handled for the intended purpose and attention is given to this technical documentation.

You, as the owner/managing operator of the machine, must ensure that the people entrusted with working on the machine:

- have noted and understood all the regulations regarding safety,
- are familiar before starting work with all the operating instructions and specifications for the target group relevant for them,
- have easy access always to the technical documentation for this machine,
- and that new personnel before starting work on the machine are familiarised with the safe handling of the machine and its use for its intended purpose, either by verbal instructions from a competent person and/or by means of this technical documentation.

Improper operation can result in personal injuries and material damage. You are responsible for your own safety and that of your employees.

Make sure that no unauthorised person has access to the machine.

 **CAUTION**

Changes to the machine

- Changes to the machine may lead to personal injury.
- **Do not make any change to the machine and use spare parts and accessories that have been approved by Retsch exclusively.**

NOTICE

Changes to the machine

- The conformity declared by Retsch with the European Directives will lose its validity.
- You lose all warranty claims.
- **Do not make any change to the machine and use spare parts and accessories that have been approved by Retsch exclusively.**

1.3 Repairs

This operating manual does not contain any repair instructions. For your own safety, repairs may only be carried out by Retsch GmbH or an authorized representative or by Retsch service engineers.

In that case please inform:

The Retsch representative in your country
Your supplier
Retsch GmbH directly

Your Service Address:

2 Confirmation

This operating manual contains essential instructions for operating and maintaining the device which must be strictly observed. It is essential that they be read by the operator and by the qualified staff responsible for the device before the device is commissioned. This operating manual must be available and accessible at the place of use at all times.

The user of the device herewith confirms to the managing operator (owner) that (s)he has received sufficient instructions about the operation and maintenance of the system. The user has received the operating manual, has read and taken note of its contents and consequently has all the information required for safe operation and is sufficiently familiar with the device.

As the owner/managing operator you should for your own protection have your employees confirm that they have received the instructions about the operation of the machine.

I have read and taken note of the contents of all chapters in this operating manual as well as all safety instructions and warnings.

User

Surname, first name (block letters)

Position in the company

Signature

Service technician or operator

Surname, first name (block letters)

Position in the company

Place, date and signature

3 Transport, scope of delivery, installation

3.1 Packaging

The packaging has been adapted to the mode of transport. It complies with the generally applicable packaging guidelines.

3.2 Transport

NOTICE

Transport

- Mechanical or electronic components may be damaged.
 - **The machine may not be knocked, shaken or thrown during transport.**
-

3.3 Temperature fluctuations and condensed water

NOTICE

Temperature fluctuations

The machine may be subject to strong temperature fluctuations during transport (e.g. aircraft transport)

- The resultant condensed water may damage electronic components.
 - **Protect the machine from condensed water.**
-

3.4 Conditions for the place of installation

NOTICE

Ambient temperature

- Electronic and mechanical components may be damaged and the performance data alter to an unknown extent.
 - **Do not exceed or fall below the permitted temperature range of the machine (5°C to 40°C / ambient temperature).**
-

3.5 Installation of the machine

Installation height: maximum 2000 m above sea level

3.6 Electrical connection

WARNING

When connecting the power cable to the mains supply, use an external fuse that complies with the regulations applicable to the place of installation .

- Please check the type plate for details on the necessary voltage and frequency for the device.
- Make sure the levels agree with the existing mains power supply.

- Use the supplied connection cable to connect the device to the mains power supply.

3.7 Type plate description

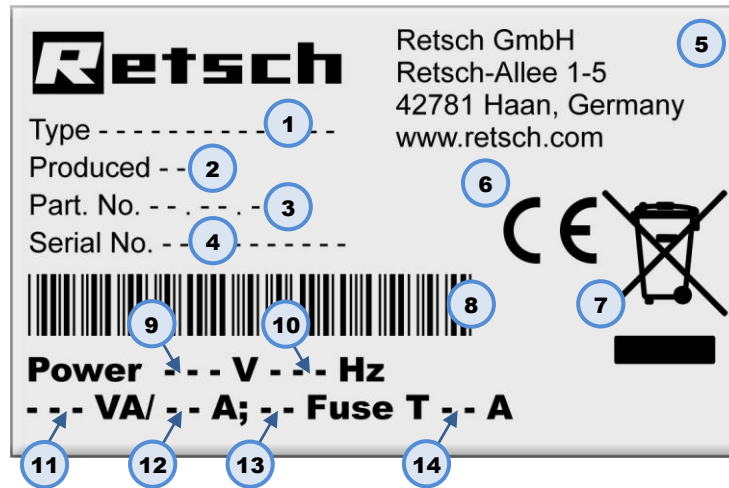

Fig. 1: Type plate lettering

- | | |
|----|-----------------------------|
| 1 | Device designation |
| 2 | Year of production |
| 3 | Part number |
| 4 | Serial number |
| 5 | Manufacturer's address |
| 6 | CE marking |
| 7 | Disposal label |
| 8 | Bar code |
| 9 | Power version |
| 10 | Mains frequency |
| 11 | Capacity |
| 12 | Amperage |
| 13 | Number of fuses |
| 14 | Fuse type and fuse strength |

In the case of questions please provide the device designation (1) or the part number (3) and the serial number (4) of the device.

4 Technical data

4.1 Use of the machine for the intended purpose

 **CAUTION**

Risk of explosion or fire

Changing sample characteristics

- Note that the characteristics and accordingly the danger presented by a sample can change during sieving.
- **Do not sieve any potentially explosive or combustible materials in this device.**

 **CAUTION**

Risk of explosion or fire

- On account of its design, the device is not suitable for use in hazardous (potentially explosive) atmospheres.

- **Do not operate the device in a hazardous atmosphere.**

 **CAUTION**

Danger of personal injury

Dangerous nature of the sample

- Depending on the dangerous nature of your sample, take the necessary measures to rule out any danger to persons.
- **Observe the safety guidelines and datasheets of your sample material.**



Target group: operators

Machine type designation: GM 200

This device is suitable for analytical grinding, homogenisation and mixing of soft to medium-hard, aqueous, fatty, fibrous and dry materials in seconds. This device is designed for quantities of approximately 700ml, large volume materials up to 1000ml.

The feed size is < 30 - 40 mm.

The device is specially designed for the grinding of the following materials :

Fish, meat, vegetables, cheese, preserves, seeds, bacon, sausage, dry baked goods and pastries, all aqueous, fatty and fibrous products and similar materials.

The device is designed as a laboratory device for 8-hour one-shift operation with a 30% ON duration.

It is not intended for use as production machine and not intended for the mixing and homogenisation of liquids with low viscosity (emulsions and suspensions) .

4.2 Working instructions

The grinding process of the device is effected through cutting and, in reverse operation, through impact effect.

The cutters are straight and are arranged at right-angles to the direction of rotation.

The cutters are slim with a cutting angle of 15° and a pre-cut (pre-grind) of 30°.

With this cutting geometry the entire inertia resulting from the speed difference between the sample material particles and the cutters can be used as cutting force.

The speed is between 2000 - 10000min⁻¹ and is altered in stages of 500min⁻¹ and displayed digitally.

The preselected speed is kept constant during grinding by a speed regulator.

Interval operation has proved to be advantageous in the pre-grinding and homogenisation of large-piece, tough, fibrous and very soft and elastic products.

The grinding duration can be set up to 3 minutes. After expiry of the grinding duration the motor automatically switches off and the housing lid opens.

3 memories permit the storage and retrieval of frequently used speed/time combinations by the press of a button.

4.3 Protective equipment

The grinding chamber of this device is interlocked by a resistant protective hood.

It is only possible to start the device when the protective hood is closed. The motor must have come to a standstill to open the device.

In the event of fault there is also an electric emergency brake which brings the cutters to a standstill in fractions of a second from the highest speed.

If the achievable current speed deviates from the setpoint speed by more than 5% due to an overload, this is shown by flashing displays.

4.4 Drive output

Universal electric motor

4.5 Rated power

Motor performance: approx. 1000 watts

4.6 Motor rotation speed

Speed: 2000 rpm⁻¹.... 10,000 rpm⁻¹ (can be altered in steps of 500 Umin⁻¹)

4.7 Rated voltage

Rated voltages:	230 V	50 Hz	(+/- 5%)
	100-120V	50/60 Hz	(+/- 5%)

4.8 Emissions



Possibility of acoustic signals not being heard

Loud grinding noises

- Acoustic alarms and voice communication might not be heard.

- **Consider the volume of the grinding noise in relation to other acoustic signals in the work environment. You may wish to use additional visual signals.**

Noise values: ~ 56 dB(A) (without sample material, beaker, cutters)

Noise measurement in accordance with DIN 45635-031-01-KL3

The noise values are also influenced by the properties of the sample medium.

4.8.1 Noise measurement Example 1:

Intensity of sound LWA

Workplace-related emission value LpAeq

Operating conditions:

Jug = glass jug with gravitation lid

Grind unit = cutter made of stainless steel

Feed material = tomatoes, quartered approx. 40 x 25mm

Feed quantity = 100g

4.8.2 Noise measurement Example 2:

Intensity of sound LWA

Workplace-related emission value LpAeq

Operating conditions:

jug = glass jug with gravitation lid

Grind unit = cutter made of stainless steel

Feed material = cheese approx. 20 x 20mm

Feed quantity = 100g

4.9 Degree of protection

- Grinding chamber and keypad - IP 42
- In the area of the ventilation slits - IP 20

4.10 Dimensions and weight

Closed:

Height: up to approx. 390mm

Width: 350mm

Depth : 250mm

with open hood:

Height: up to approx. 540mm

Width: 350mm

Depth : 410mm

Weight: approx. 10.1kg (without plastic container and cutter)

4.11 Required floor space

200 mm x 400 mm; no safety distances required.

5 Operating the machine

5.1 Views of the Instrument

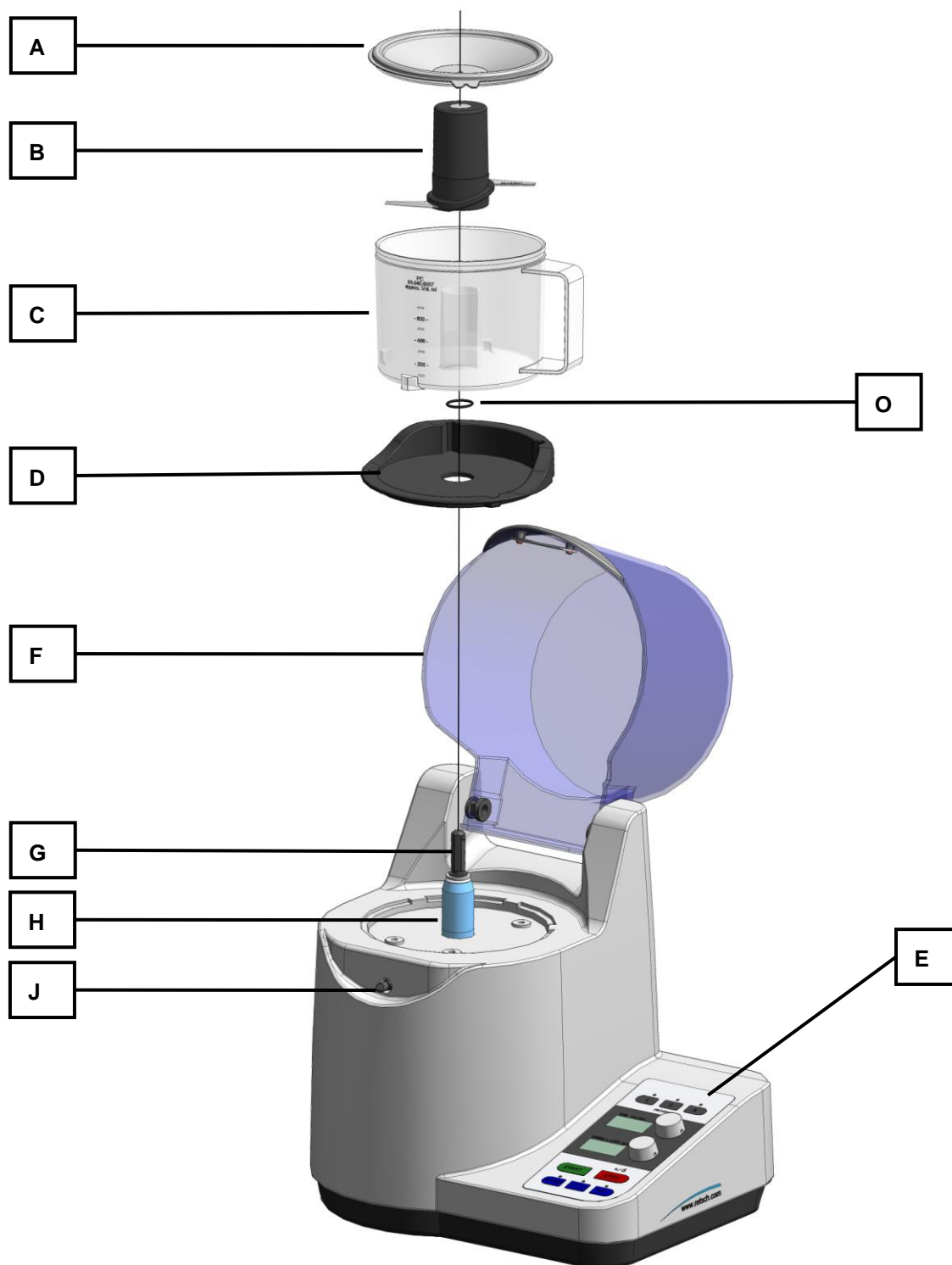

Fig. 2: Front view of the machine



Fig. 3: Rear view of the machine

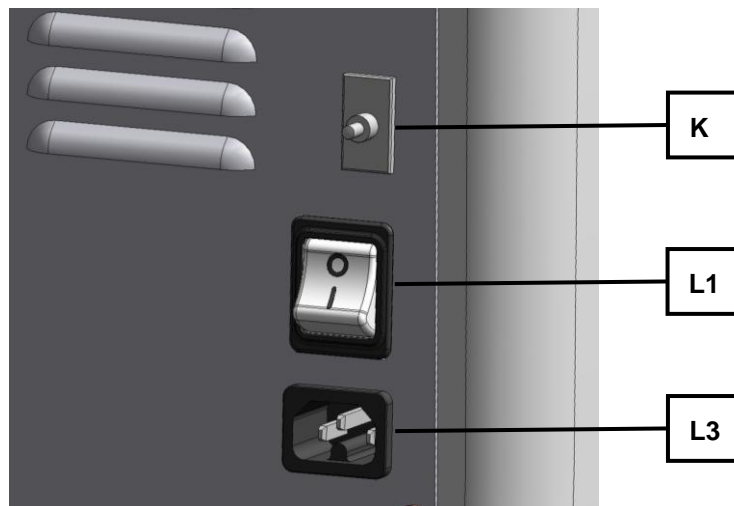

Fig. 4: Detail view of the socket for non-heating apparatus

5.2 Overview table of the parts of the device

Element	Description	Function
A	Jar lid	Seals the grinding jar
B	Knife cylinder	Cuts and grinds the sample material
C	Grinding jar	Holds the sample material
D	Jar holder	Holder for the grinding jar
E	Operating panel with displays	Start / stop / program memory and displays
F	Grinding chamber hood	Protective hood for safe grinding operations
G	Pin for knife cylinder	Drive shaft for knife cylinder
H	Support for grinding jar	Centres the grinding jar and the jar holder
J	Grinding chamber hood interlock	Locks the grinding chamber hood into place
K	Thermal fuse	Protective switch against overheating
L1	On/off switch	Separates the machine completely from the mains
L3	Socket for non-heating apparatus	Connection for mains cable
M	Vent	Ventilation of motor and inside chamber
O	O ring	Fixes the grinding chamber holder

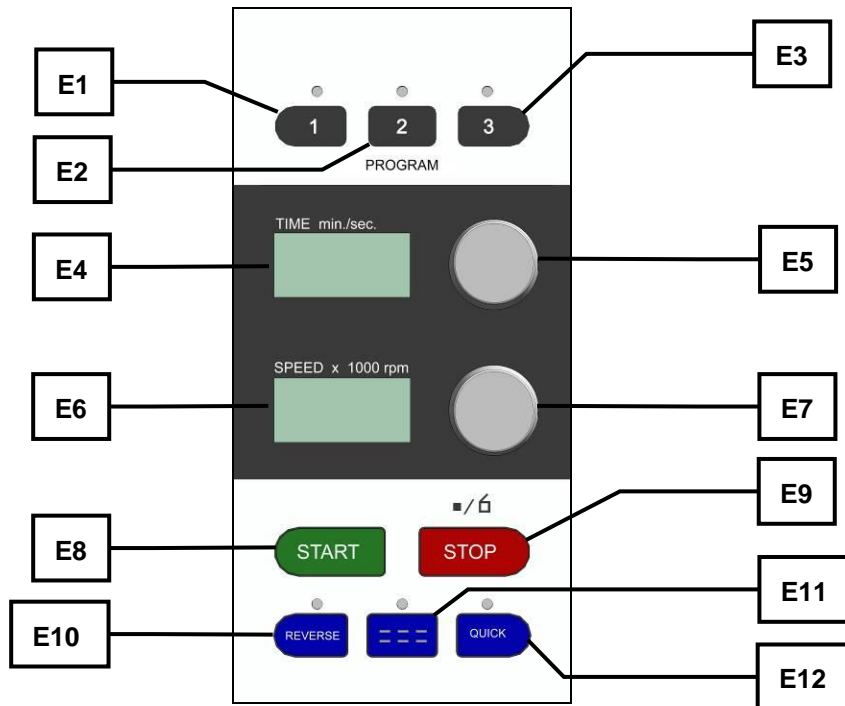

Fig. 5: Operating elements and displays

5.3 Overview Table of the Operating Elements and the Display

Element	Description	Function
E1	Program 1	Memory for program function
E2	Program 2	Memory for program function
E3	Program 3	Memory for program function
E4	Time display	Display of the remaining grinding time
E5	Time knob	Grinding time setting (1 second to 3 minutes)
E6	Speed display	Display of the set speed
E7	Speed knob	Speed setting
E8	START button	Start of grinding
E9	STOP / open button	End of grinding / opening of the protective hood
E10	REVERSE button	Direction reversal
E11	INTERVAL button	Grinding with short intervals
E12	QUICK button	Manually controlled grinding

5.4 Operating the Device

 **CAUTION**

Device falling down

Incorrect assembly or unsuitable workplace

- The appliance is very heavy and can therefore cause serious personal injuries if it falls down.

- **Operate the device only on a sufficiently large, firm, skid-resistant and steady workplace.**

- **Make sure that all equipment feet are steady.**

 **CAUTION**

Damage to hearing

The level of noise can be high depending on the type of material, the knife used, the speed set and the duration of the grinding process.

- Noise that is excessive in terms of level and duration can cause impaired or permanently damaged hearing.

- **Ensure suitable sound-proofing measures or wear hearing protection.**



5.5 Switching On and Off

The main switch is located on the reverse side of the device (L1).

- Switch the main switch on.

The grinding time last used appears in the TIME display.

The speed last used appears in the SPEED display.

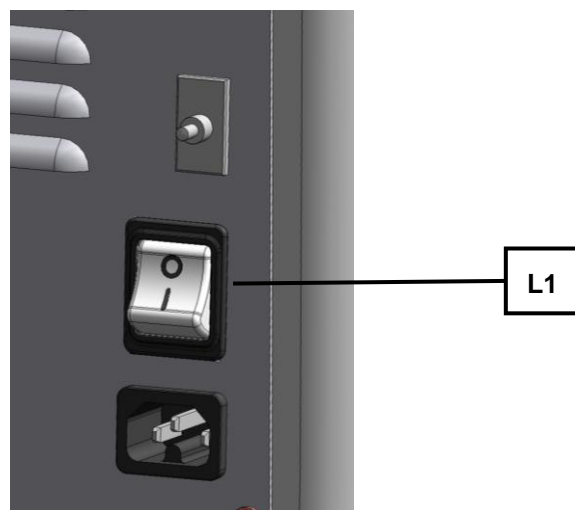

Fig. 6: Main switch

5.6 Opening and closing of the grinding chamber

 **CAUTION**

Crushed or bruised fingers

Falling grinding chamber protective hood

- The protective hood of the grinding chamber can cause crushed or bruised fingers if it falls down.
- **Hold the flap tight when closing.**

- Briefly press the STOP button (E9).
The hood is unlocked and opens.

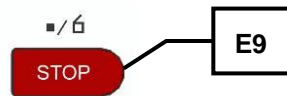

Fig. 7: Opening hood

5.7 Inserting the grinding jar

- Open the hood.
- Insert the jug.

Pay attention to the position of the jug when it is inserted.

N.B.

Ensure the correct position of the O ring (O).

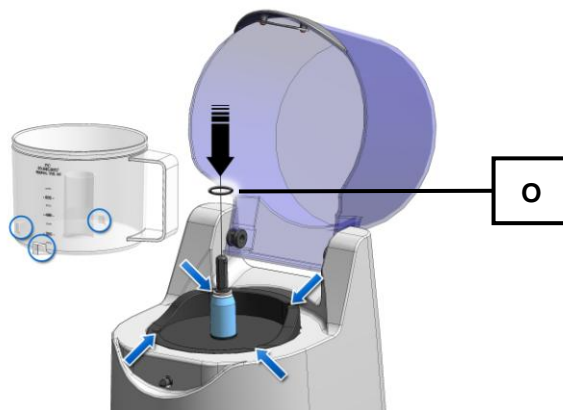

Fig. 8: Inserting jug

5.8 Use of grinding jugs depending on different materials

NOTICE

Grinding with liquid nitrogen (LN₂) or dry ice (CO₂) is not permitted in any variation of the GM.

Danger from brittleness and breakage of grinding tools or the glass and plastic containers.

1.H0053

5.8.1 Grinding jars – plastic jugs (PP)

Suitable for the following sample materials:

soft, medium-hard, elastic, aqueous, fatty and oily.

Unsuitable for the following sample materials:

hard, hard-brittle,

e.g. cereals, pellets, gelatine sweets.

(increased friction in the plastic jug)

5.8.2 Grinding jars – glass jugs (borosilicate glass 3.3)

Suitable for the following sample materials:

soft, medium-hard, elastic, aqueous, fatty and oily.

Unsuitable for the following sample materials:

hard, hard-brittle,

e.g. cereals, pellets, gelatine sweets.

(glass jugs can break)

5.8.3 Grinding jars – stainless steel jugs

Suitable for the following sample materials:

soft, medium-hard, elastic, aqueous, fatty and oily, hard to medium-hard

e.g. cereals, frozen food, sweets, hard cheese and cold meat/sausage products

5.9 Lid and jug combinations



CAUTION

1.V0028

Danger of injuries caused by cuts

Moving parts – jug, rotor and grinding jar lid

– The jug and the rotor may fall down after removal and cause injury.

- **Be aware and put down the components safely.**
- **Do not place any objects on the device.**

The different lid / jug combinations will accommodate the different tasks.

NOTE

Pay attention to the maximum feed quantity of 300ml.

In the case of aqueous materials the jug may otherwise overflow during grinding.

Exceeding the non-recommended feed quantities.

5.9.1 Lid 1000ml

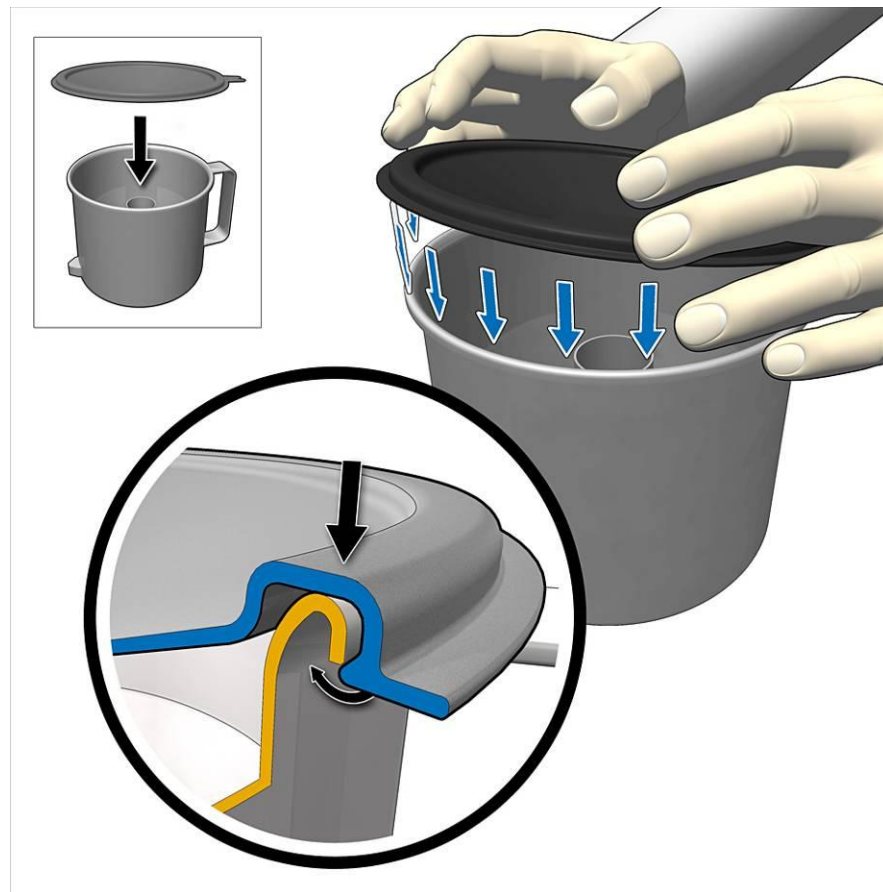

The 1000ml lid is used for larger quantities of small-piece material. The feed quantity ranges between 300 and a maximum of 700ml.

The lid is snapped on to the edge of the jug and can be released again by pulling up the flap.

NOTE

The 1000ml lid may be used both on the plastic and on the glass jug.

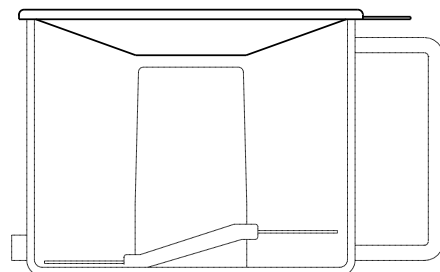

Fig. 2: 1000ml lid

5.9.2 Lid 500ml

The 500ml lid is used for smaller quantities of small-piece material. The feed quantity is a maximum of 300ml, depending on the material to be ground.

- Position the 500ml lid such that the edge is over the top edge of the jug. During grinding the 500ml lid is held down by the hood.

NOTE

The 500ml lid can only be used with the plastic jug.

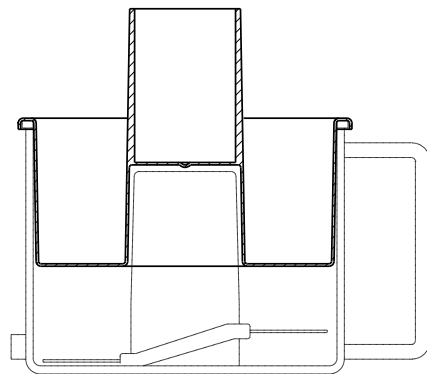

Fig. 3: 500ml lid

5.9.3 Gravitation lid

The gravitation lids permit an exact adjustment of the useful volume to the respective feed quantity. They move downwards during grinding, thereby optimising the grinding chamber volume. The feed quantity is a maximum of 300ml.

The gravitation lid with overcurrent channels (↻) is used for aqueous materials.

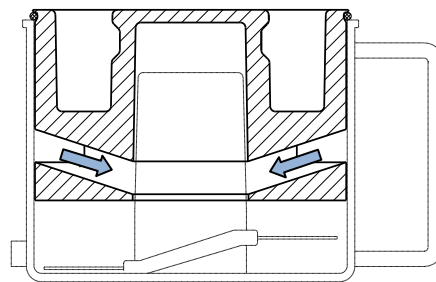

Fig. 4: Gravitation lid with overcurrent channels

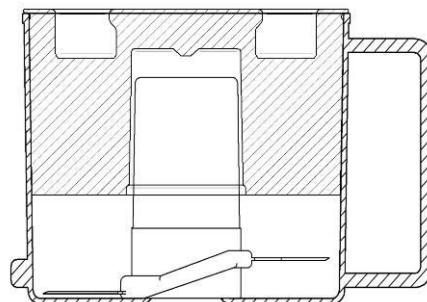

Fig. 5: Gravitation lid

NOTE

The gravitation lids for the plastic jug differ from the gravitation lids for the glass and steel grinding jugs.

5.10 Filling the vessel



2.V0039

Danger of injuries caused by cuts

Sharp cutters

- The cutters are very sharp and may lead to injuries caused by cuts if handled incorrectly.
- **Do not directly take hold of the cutters.**
- **Only reach into the grinding jar if it is outside the device.**
- **Do not reach into the grinding jar if the sample material still covers the cutter.**
- **Before taking out the cutter remove as much sample material to safely grip the cutter.**

NOTE

3.H0054

The hood must safely latch into the interlock pin so that the motor can start or so that no emergency brake is triggered during grinding.

Insert the cutter cylinder before adding the sample material because otherwise it may fall between cutter cylinder and jug.

5.10.1 Filling – within the device

- Insert the jug.
- Position the cutter cylinder and push it down as far as it will go.
- Add the sample material.
- Put on the lid.
- Close the hood until it latches into the interlock pin (**J**).

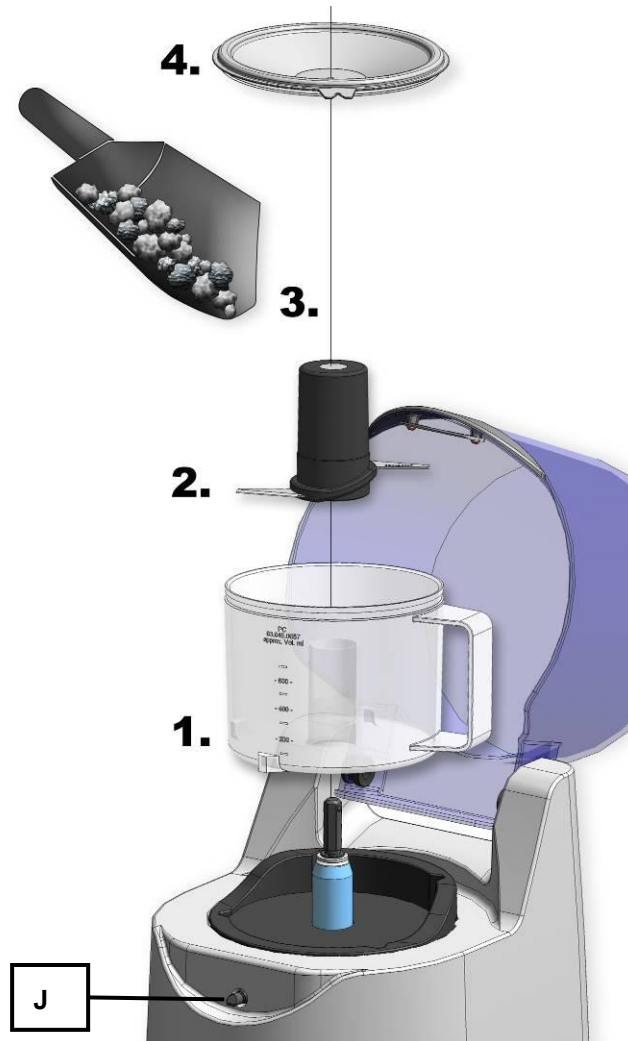

Fig. 6: Filling inside the device

5.10.2 Filling – outside the device

The jug can also be filled before positioning in the device. This means that you can work without problem with several jugs without intermediate cleaning.

The jugs can only be charged outside the machine with the 500ml and 1000ml lids; the gravitation lid is not suitable for this purpose.

- Place the cutter cylinder into the jug.
- Add the sample material.
- Position the lid.
- Press the lid in the centre downwards and place the jug into the device.

In the case of the 500ml lid it is essential to push it down so that the cutter cylinder reaches its final position.

Do not use the gravitation lid when filling the jug outside the machine since otherwise the cutter will not interlock.

- Close the hood until it latches in the interlock pin.

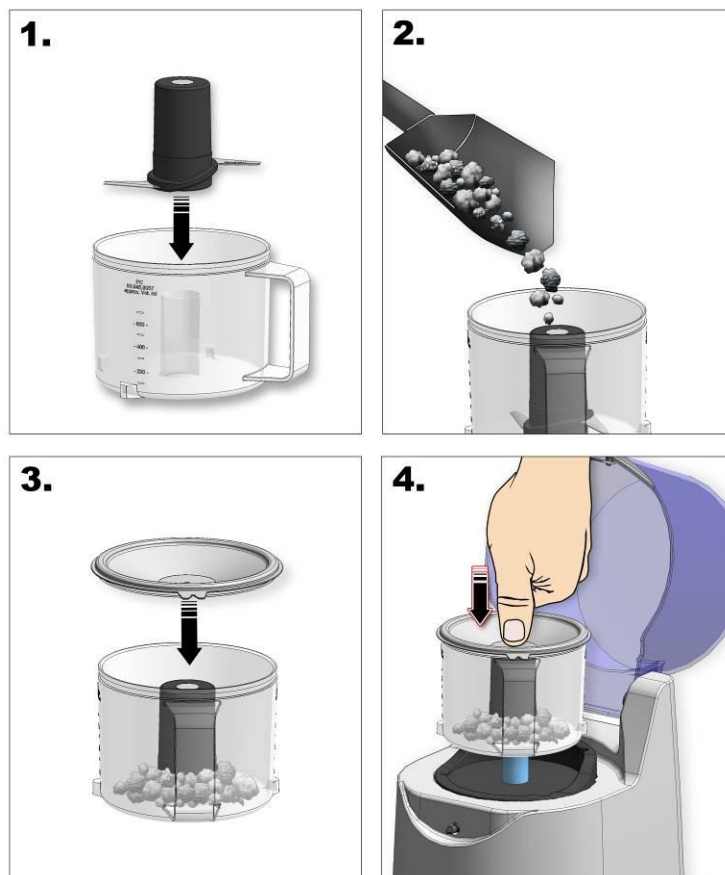
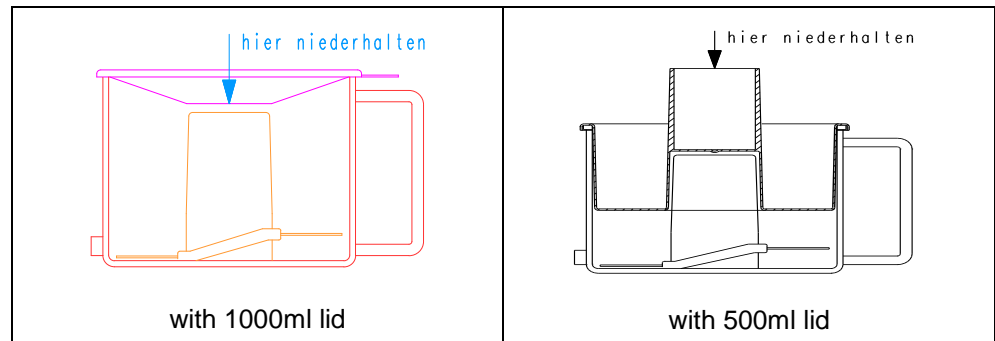

Fig. 7: Filling outside the device

5.11 Setting the grinding time

The grinding duration can be set from 1 second to 3 minutes in steps of 1 second.

- Turn the knob (E5) to the left to reduce the grinding duration.
- Turn the knob (E5) to the right to increase the grinding duration.

Turning slowly increases the time in steps of 1 second.

Turning quickly increases the grinding duration in steps of 1 minute.

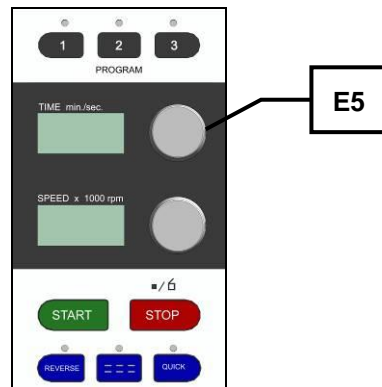

Fig. 8: Setting grinding duration

5.12 Setting the Speed

The speed can be set from 2000 min⁻¹ to 10.000 min⁻¹ in steps of 500 min⁻¹.

- Turn the knob (E7) to the left to reduce the speed.
- Turn the knob (E7) to the right to increase the speed.

Slow turning alters the speed in steps of 500 min⁻¹.

Fast turning alters the speed in steps of 3000 min⁻¹.

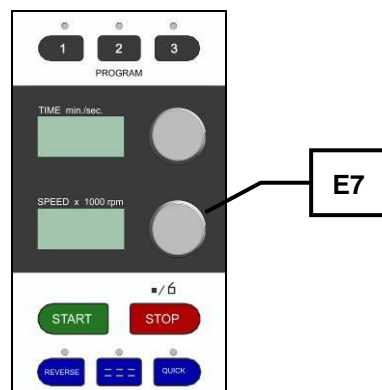

Fig. 9: Setting the speed

5.13 Switching on interval or continuous mode

- Press the interval button (E11).

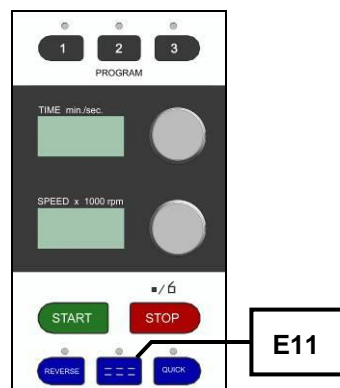

Fig. 10: Switching on interval operation

The LED over the button lights up. The set speed is shown in the display if it is not larger than 4000 rpm.

- Press the START button.

Grinding now takes places in the interval mode.

- To end interval grinding press the interval button (**E11**) once again.

The LED above the interval button goes out and the speed maintains the value of 4000 rpm. The device is in continuous mode again .

5.14 Reverse grinding

- Press the REVERSE button (**E10**).

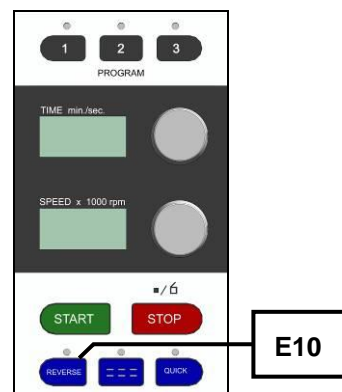

Fig. 11: Switching on interval operation

The LED above the REVERSE button lights up.

- Press the START button.

Grinding takes place in reverse mode and the motor runs against the cutting direction. Grinding takes place by impact unlike normal mode (cutting).

- Press the REVERSE button (**E11**) to leave the reverse mode again.

The LED above the REVERSE button lights up. The device is in normal mode once again – grinding by cutting .

- Press the QUICK button (**E12**).

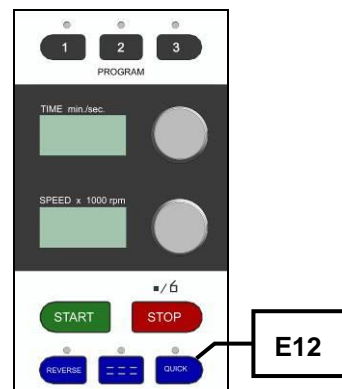

Fig. 12: QUICK grinding

The LED above the button lights up and grinding starts immediately.

- Release the QUICK button, grinding is ended immediately and the LED above the button goes out.

5.15 Store functions

5.15.1 Saving programs

- Keep the button **E1**, **E2** or **E3** pressed until the segment displays no longer flash.

The values for time and speed as well as the setting for REVERSE and INTERVAL operation are stored in the memory of the corresponding button.

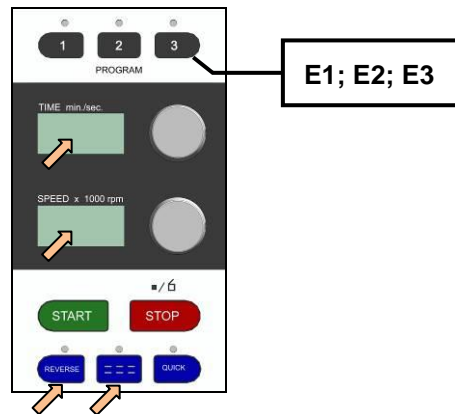

Fig. 13: Memory buttons

5.15.2 Starting a saved program

- Press the **E1**, **E2** or **E3** button.

The last saved values appear on the “TIME“ and “SPEED“ segment displays. The LEDs above the REVERSE and INTERVAL buttons light up depending on default.

Press the START button to start grinding with the default parameters.

5.16 Start – Pause – Stop

5.16.1 Pause function

- Press the STOP button during grinding.

Grinding is interrupted and the hood remains closed.

It is not possible to move the set parameters (speed, time, interval, reverse). The current time display is suspended.

- Press the START button to continue grinding.

Grinding is restarted and the time display runs again.

5.16.2 Premature termination of grinding

- Press the STOP button during grinding.

Grinding is interrupted and the hood remains closed.

- Press the STOP button again.

The device is switched off and the hood opens automatically. The parameters chosen for grinding (speed, time, interval, reverse) are displayed.

5.17 Resetting the overload protection

The overload protection switch (**K**) is situated on the rear panel.

This overload protection switch disconnects the device from the power supply if the machine is overloaded.

- After allowing the device to cool down it can be used with the power supply again by pressing the overload protection switch (**K**).

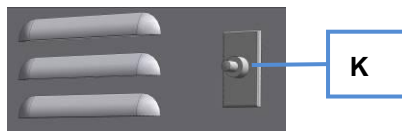

Fig. 14: Overload protection switch

6 Cleaning and service

 **WARNING**

Risk of a fatal electric shock

- An electric shock can cause injuries in the form of burns and cardiac arrhythmia, respiratory arrest or cardiac arrest.
- **Do not clean the blender under running water. Use only a cloth dampened with water.**
- **Disconnect the power supply plug before cleaning the blender.**

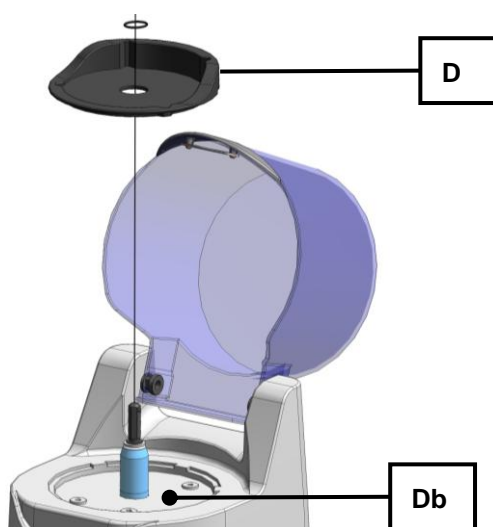

Fig. 15: Cleaning the jar support

NOTE

Sample material may get underneath the jar support (**Db**) where the jar support (**D**) frequently gets very dirty as a result of liquid or greasy samples.

- Where necessary also clean the area underneath the jar support (**Db**).

Material may otherwise, under unfavourable circumstances, get inside the device.

6.1 Cleaning the Grinding Tools

Material/device part	Dishwasher-proof	Autoclavable
Knife (stainless steel)	yes	yes
Knife (pure titanium)	yes	yes
Standard lid	yes	yes
Gravitation lid	yes	yes
Gravitation lid with overcurrent channels	yes	yes
Reduction lid	yes	yes
Plastic container (PP)	yes	no
Plastic container (PC)	yes	yes
Glass container	yes	yes
Stainless steel container	yes	yes

NOTICE

H0052

- Pay attention to the position of parts in the dishwasher.
- Do not place the plastic container, plastic lid or the knife near the heating element. Deformation can otherwise not be ruled out and further use of the parts will no longer be possible.

6.2 Check the sealing lip

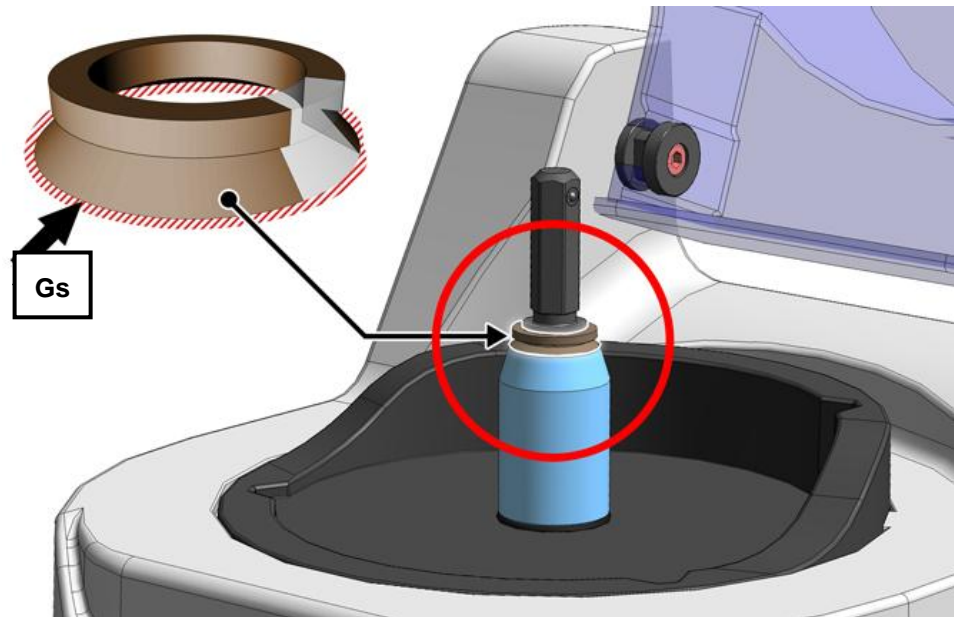

Fig. 16: Sealing lip (Gs)

Check the sealing lip (Gs) for damage at regular intervals.

- Replace the sealing lip (Gs) if damaged. [No. 05.111.0239]

Notice

Moisture can penetrate the inside of the housing if the sealing lip (Gs) is damaged.

7 Fault messages

F01	Motor is not running	
F02	Motor is switched off due to overload	Restart grinding process with small feed quantity.
F03	Motor speed too low / high	
F04	Hood open	
F05	Braking time too high	
F06	Motor overheated	Allow motor to cool and restart.
F07	Hood monitoring defective	Check the fault message: Press the START button when the hood is open. The "time" and "speed" segment displays flash evenly. Close the hood to rectify fault.
F08	Overspeed through hardware	

8 Disposal

Please observe the respective statutory requirements with respect to disposal.

Information on disposal of electrical and electronic machines in the European Community.

Within the European Community the disposal of electrically operated devices is regulated by national provisions that are based on the EU Directive 2002/96/EC on Waste Electrical and Electronic Equipment (WEEE).

Accordingly, all machines supplied after 13.08.2005 in the business-to-business area to which this product is classified, may no longer be disposed of with municipal or household waste. To document this they have the following label:

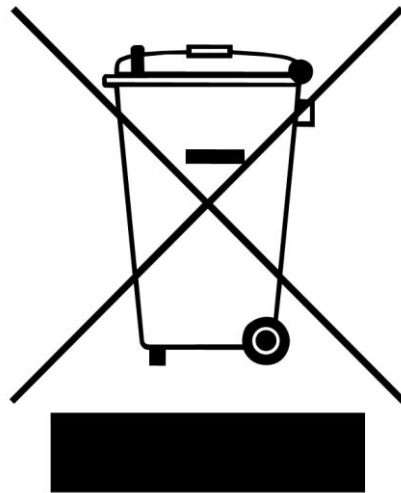

Fig. 17: Disposal label

Since the disposal regulations within the EU may differ from country to country we would request you to consult your supplier.

9 Index

1	
1000ml lid	24
5	
500ml lid	24
A	
Amperage	11
aqueous	22
B	
Bar code	11
Borosilicate glass	22
C	
Capacity	11
CE marking	11
Changes	5
Cleaning and service	31
Cleaning the Grinding Tools	32
Conditions for the place of installation	10
Confirmation	9
Connection cable	11
Continuous grinding	29
Continuous mode	29
Copyright	5
D	
dB(A)	14
Degree of protection	14
Detail view of the socket for non-heating apparatus	17
Device designation	11
Dimensions and weight	14
DIN 45635-031-01-KL3	14
Disposal	35
Disposal label	11
Disposal label	35
Drive output	13
E	
elastic	22
Electrical connection	10
Emissions	14
Emulsions	12
Explanations of the safety warnings	6
External fuse	10
F	
F01	34
F02	34
F03	34
F04	34
F05	34
F06	34
F07	34
F08	34
fatty	22
Fault messages	34
Feed size	12
Filling – outside the device	26
Filling – within the device	25
Filling inside the device	26
Filling outside the device	27
Filling the vessel	25
Front view of the machine	16
Fuse strength	11
Fuse type	11
G	
General safety instructions	7
Glass jugs	22
Gravitation lid	24
H	
hard	22
hard-brittel	22

I		P	
Inserting jug	21	Packaging	10
Inserting the grinding jar	21	Part number	11
Installation height.....	10	Pausen function	30
Installation of the machine	10	Plastic jugs	22
Interval grinding	29	Power version	11
L		Premature termination of grinding	30
Lid 1000ml	23	property damage.....	6
Lid 500ml	24	Protective equipment	13
Lid and jug combinations	22	Q	
LWA	14	QUICK grinding.....	29
M		R	
Main switch	21	Rated power.....	13
Mains frequency	11	Rated voltage.....	13
Manufacturer's address	11	Rear view of the machine	17
Materials	12	Regulations for the place of installation	10
medium-hard.....	22	Repairs.....	8
Memory buttons	30	Required floor space.....	15
Moderate or mild injury	6	Resetting the overload protection	30
Motor rotation speed.....	13	Reverse grinding.....	29
N		S	
Noise measurement.....	14	Safety warnings	6
noise values.....	14	Sample materials	22
Notes on the Operating Manual.....	5	Saving programs.....	30
Number of fuses	11	Sealing lip	33
O		Serial number.....	11
oily.....	22	serious injury.....	6
Opening and closing of the grinding chamber	21	Service Address.....	8
Opening hood	21	Setting grinding duration	28
Operating elements and displays	19	Setting the grinding time	27
Operating the Device	20	Setting the speed	28
Operating the machine	16	Setting the Speed	28
Overcurrent channels	24	soft	22
Overload protection switch	31	Sound level	14
Overview Table of the Operating Elements and the Display	19	Stainless steel jugs	22
Overview table of the parts of the device	18	Start – Pause – Stop.....	30
		Starting a saved program	30
		Store functions	30

Suspensions	12
Switching On and Off.....	20
Switching on interval operation.....	28, 29
Switching on interval or continuous mode	28

T

Target group	7
Technical data	12
Temperature fluctuation and condensed water ..	10
Transport	10
Transport, scope of delivery, installation	10
Type plate	10
type plate description.....	11
Type plate lettering	11

U

Use of grind jugs depending on different materials	21
Use of the machine for the intended purpose....	12

V

Views of the Instrument	16
Viscosity	12

W

Working instructions.....	13
Workplace-related emission value	14

Y

Year of production.....	11
-------------------------	----

LABORATORY KNIFE MILL

GM 200 - GRINDOMIX

Certificate of CE-Conformity according to:

EC Mechanical Engineering Directive 2006/42/EC

Applied harmonized standards, in particular:

DIN EN ISO 12100	Security of machines
DIN EN ISO 12852-5.1.1	Food processors and blenders
DIN EN ISO 13849-1	Safety related parts of control systems

EC Directive Electromagnetic Compatibility 2004/108/EC

Applied standards, in particular:

DIN EN 55011	Emission	
DIN EN 61000-3-2	DIN EN 61000-3-3	Emission
DIN EN 61326-1	Immunity	

Additional applied standards, in particular

DIN EN 61010-1	Safety prescriptions concerning measuring-, operating-, controlling- and laboratory equipment
----------------	---

Authorized person for the compilation of technical documents:

J. Bunke (technical documentation)

The following records are held by Retsch GmbH in the form of Technical Documentation:

Detailed records of engineering development, construction plans, study (analysis) of the measures required for conformity assurance, analysis of the residual risks involved and operating instructions in due form according to the approved regulations for preparation of user information data.

The CE-conformity of the Retsch Laboratory Knife Mill GM 200 is assured herewith.

In case of a modification to the machine not previously agreed with us as well as the use of not licensed spare parts and accessories this certificate will lose its validity.

Retsch GmbH

Haan, March 2011

Ralf Eisenbach Dipl.-Ing.





Copyright

® Copyright by
Retsch GmbH
Haan, Retsch-Allee 1-5
D-42781 Haan
Federal Republic of Germany