

Manual Cutting Mill SM200

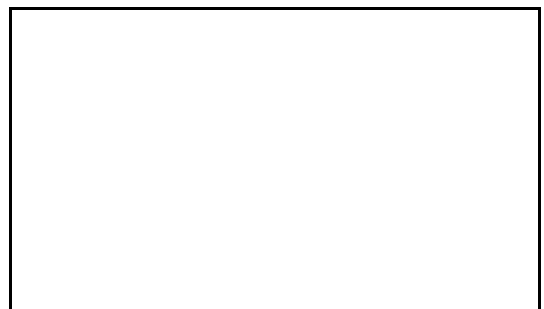

Translation

Retsch[®]

Copyright

© Copyright by
Retsch GmbH
Haan, Retsch-Allee 1-5
D-42781 Haan
Federal Republic of Germany

1	Notes on the Operating Manual	5
1.1	Explanations of the safety warnings	6
1.2	General safety instructions	7
1.3	Repairs.....	8
2	Confirmation	9
3	Transport, scope of delivery, installation	10
3.1	Packaging	10
3.2	Transport.....	10
3.3	Temperature fluctuations and condensed water	10
3.4	Conditions for the place of installation	10
3.5	Electrical connection	11
3.6	Type plate description.....	11
3.7	Removing Transport Safeguards.....	12
3.8	Mounting the Feed Hopper	12
3.8.1	Removing the Transport Safeguard	13
3.8.2	Mounting the Feed Hopper	13
3.9	Installation of the machine	14
4	Technical data	16
4.1	Use of the machine for the intended purpose.....	16
4.2	Emissions.....	17
4.3	Degree of protection	17
4.4	Motor rotation speed	18
4.5	Receptacle volume	18
4.6	Rated power	18
4.7	Dimensions and weight.....	18
4.8	Required floor space.....	18
5	Operating the machine	19
5.1	Views of the Instrument	19
5.2	Overview table of the parts of the device	22
5.3	Operating elements and displays	23
5.4	Overview Table of the Operating Elements and the Display.....	23
5.5	Opening and closing of the grinding chamber	24
5.6	Mounting the bottom sieve.....	24
5.7	Replacing the rotor	24
5.7.1	Removing the Rotor	25
5.7.2	Inserting the Rotor	25
5.8	Inserting the filter unit and collecting receptacle.....	26
5.9	Starting the grinding process	26

5.10	Stopping the grinding process	27
6	Mode of Operation of Feed Hopper	28
7	Assembling and using the cyclone	29
7.1	Cyclone assembly.....	29
7.1.1	Inserting the wide mouth bottle adapter	33
8	Cleaning and service	34
8.1	Adjusting the cutting bars	34
9	Fault messages.....	37
10	Disposal.....	38
11	Index	39
Appendix	following pages

1 Notes on the Operating Manual

This operating manual is a technical guide on how to operate the device safely and it contains all the information required for the areas specified in the table of contents. This technical documentation is a reference and instruction manual. The individual chapters are complete in themselves.

Familiarity (of the respective target groups defined according to area) with the relevant chapters is a precondition for the safe and appropriate use of the device.

This operating manual does not contain any repair instructions. If faults arise or repairs are necessary, please contact your supplier or get in touch with Retsch GmbH directly.

Application technology information relating to samples to be processed is not included but can be read on the Internet on the respective device's page at www.retsch.com.

Changes

Subject to technical changes.

Copyright

Disclosure or reproduction of this documentation, use and disclosure of its contents are only permitted with the express permission of Retsch GmbH.

Infringements will result in damage compensation liability.

1.1 Explanations of the safety warnings

In this Operating Manual we give you the following safety warnings

Serious injury may result from failing to heed these safety warnings. We give you the following warnings and corresponding content.

 **WARNING**

Type of danger / personal injury

Source of danger

- Possible consequences if the dangers are not observed.
 - **Instructions on how the dangers are to be avoided.**
-

We also use the following signal word box in the text or in the instructions on action to be taken:

 **WARNING**

Moderate or mild injury may result from failing to heed these safety warnings. We give you the following warnings and corresponding content.

 **CAUTION**

Type of danger / personal injury

Source of danger

- Possible consequences if the dangers are not observed.
 - **Instructions on how the dangers are to be avoided.**
-

We also use the following signal word box in the text or in the instructions on action to be taken:

 **CAUTION**

In the event of possible **property damage** we inform you with the word “Instructions” and the corresponding content.

NOTICE

Nature of the property damage

Source of property damage

- Possible consequences if the instructions are not observed.
 - **Instructions on how the dangers are to be avoided.**
-

We also use the following signal word in the text or in the instructions on action to be taken:

NOTICE

1.2 General safety instructions

 **CAUTION**

Read the Operating Manual

Non-observance of these operating instructions

- The non-observance of these operating instructions can result in personal injuries.
- **Read the operating manual before using the device.**
- **We use the adjacent symbol to draw attention to the necessity of knowing the contents of this operating manual.**



Target group : All persons concerned with the machine in any form

This machine is a modern, high performance product from Retsch GmbH and complies with the state of the art. Operational safety is given if the machine is handled for the intended purpose and attention is given to this technical documentation.

You, as the owner/managing operator of the machine, must ensure that the people entrusted with working on the machine:

- have noted and understood all the regulations regarding safety,
- are familiar before starting work with all the operating instructions and specifications for the target group relevant for them,
- have easy access always to the technical documentation for this machine,
- and that new personnel before starting work on the machine are familiarised with the safe handling of the machine and its use for its intended purpose, either by verbal instructions from a competent person and/or by means of this technical documentation.

Improper operation can result in personal injuries and material damage. You are responsible for your own safety and that of your employees.

Make sure that no unauthorised person has access to the machine.

 **CAUTION**

Changes to the machine

- Changes to the machine may lead to personal injury.
- **Do not make any change to the machine and use spare parts and accessories that have been approved by Retsch exclusively.**

NOTICE

Changes to the machine

- The conformity declared by Retsch with the European Directives will lose its validity.
- You lose all warranty claims.
- **Do not make any change to the machine and use spare parts and accessories that have been approved by Retsch exclusively.**

1.3 Repairs

This operating manual does not contain any repair instructions. For your own safety, repairs may only be carried out by Retsch GmbH or an authorized representative or by Retsch service engineers.

In that case please inform:

The Retsch representative in your country
Your supplier
Retsch GmbH directly

Your Service Address:

2 Confirmation

This operating manual contains essential instructions for operating and maintaining the device which must be strictly observed. It is essential that they be read by the operator and by the qualified staff responsible for the device before the device is commissioned. This operating manual must be available and accessible at the place of use at all times.

The user of the device herewith confirms to the managing operator (owner) that (s)he has received sufficient instructions about the operation and maintenance of the system. The user has received the operating manual, has read and taken note of its contents and consequently has all the information required for safe operation and is sufficiently familiar with the device.

As the owner/managing operator you should for your own protection have your employees confirm that they have received the instructions about the operation of the machine.

I have read and taken note of the contents of all chapters in this operating manual as well as all safety instructions and warnings.

User

Surname, first name (block letters)

Position in the company

Signature

Service technician or operator

Surname, first name (block letters)

Position in the company

Place, date and signature

3 Transport, scope of delivery, installation

3.1 Packaging

The packaging has been adapted to the mode of transport. It complies with the generally applicable packaging guidelines.

NOTICE

Storage of packaging

- In the event of a complaint or return, your warranty claims may be endangered if the packaging is inadequate or the machine has not been secured correctly.
 - **Please keep the packaging for the duration of the warranty period.**
-

3.2 Transport

NOTICE

Transport

- Mechanical or electronic components may be damaged.
 - **The machine may not be knocked, shaken or thrown during transport.**
-

3.3 Temperature fluctuations and condensed water

NOTICE

Temperature fluctuations

The machine may be subject to strong temperature fluctuations during transport (e.g. aircraft transport)

- The resultant condensed water may damage electronic components.
 - **Protect the machine from condensed water.**
-

3.4 Conditions for the place of installation

NOTICE

Ambient temperature

- Electronic and mechanical components may be damaged and the performance data alter to an unknown extent.
 - **Do not exceed or fall below the permitted temperature range of the machine (5°C to 40°C / ambient temperature).**
-

Atmospheric humidity:

Maximum relative humidity 80% at temperatures up to 31°C, decreasing linearly up to 50% relative humidity at 40°C

NOTICE

Atmospheric humidity

- Electronic and mechanical components may be damaged and the performance data alter to an unknown extent.
- **Do not exceed the admissible range for atmospheric humidity.**

3.5 Electrical connection

⚠ WARNING

When connecting the power cable to the mains supply, use an external fuse that complies with the regulations applicable to the place of installation .

- Please check the type plate for details on the necessary voltage and frequency for the device.
- Make sure the levels agree with the existing mains power supply.
- Use the supplied connection cable to connect the device to the mains power supply.

NOTICE

Electrical connection

- Mechanical or electronic components may be damaged.
- **Please observe the information on the type plate.**

3.6 Type plate description



Fig. 1: Type plate lettering

- 1 Device designation
- 2 Year of production
- 3 Part number
- 4 Serial number
- 5 Manufacturer's address

- 6 CE marking
- 7 Disposal label
- 8 Bar code
- 9 Power version
- 10 Mains frequency
- 11 Capacity
- 12 Amperage
- 13 Number of fuses
- 14 Fuse type and fuse strength

In the case of questions please provide the device designation (1) or the part number (3) and the serial number (4) of the device.

3.7 Removing Transport Safeguards

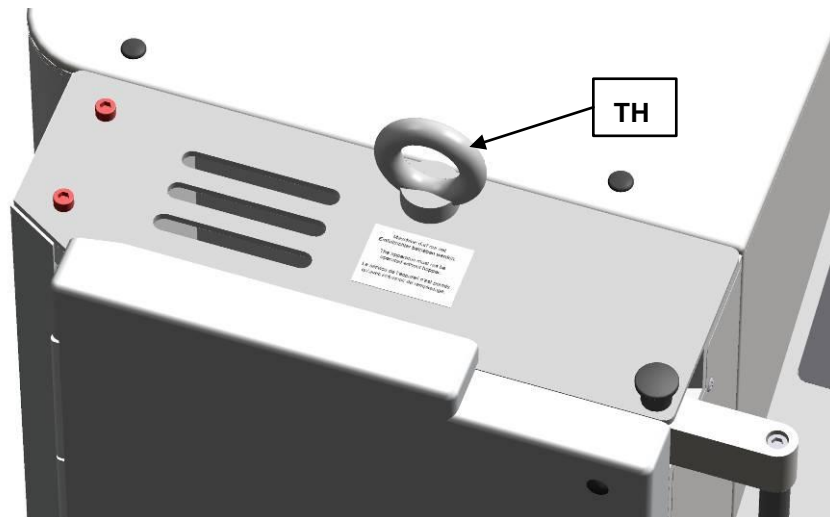

Fig. 2: Removing the transport aid

Lift the device only by the transport aid (TH). The weight of the device is approx. 90 kg. Choose a safe lifting sling that is approved for this weight.

Keep the eye bolt(TH) for transport again at a later date.

The eye bolt must be removed before the hopper is assembled.

3.8 Mounting the Feed Hopper

 **WARNING**

1.1W0004

Risk of injury to skin and hands

Fast rotating cutting blade

- There is a risk of injuring hands, fingers and skin.
 - **Never operate the device without a feed hopper.**
-

NOTICE

Transport safeguard

- Components may be damaged.
- **Operate the machine only without the transport safeguard or transport the machine only with transport safeguard.**

3.8.1 Removing the Transport Safeguard

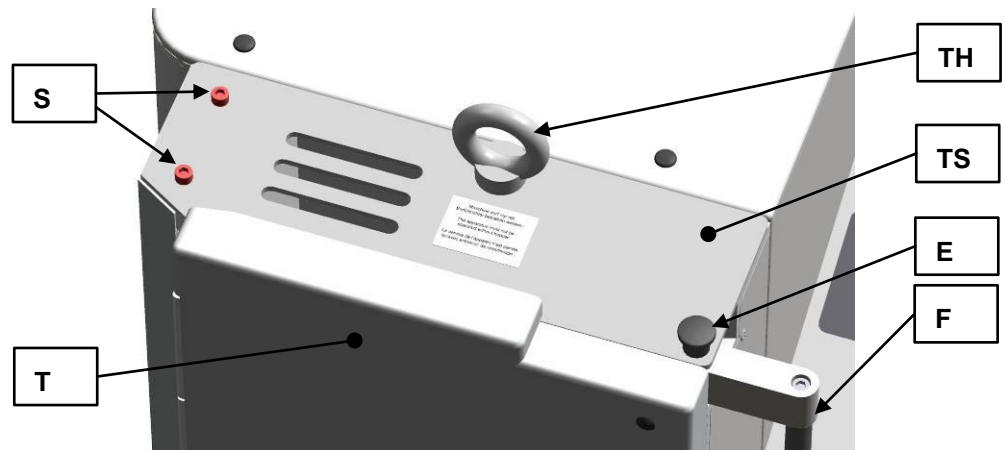

Fig. 3: Removing the transport aid

- Remove the transport aid (TH).
- Unlock the grinding chamber door, by pulling the mini detent pin (E) upwards and pressing the handle of the door latch (F) backwards.
- Open the grinding chamber door (T).
- Remove the two locking screws (S).

NOTE

Keep the transport safeguard (TS) for transport at a later date.

3.8.2 Mounting the Feed Hopper

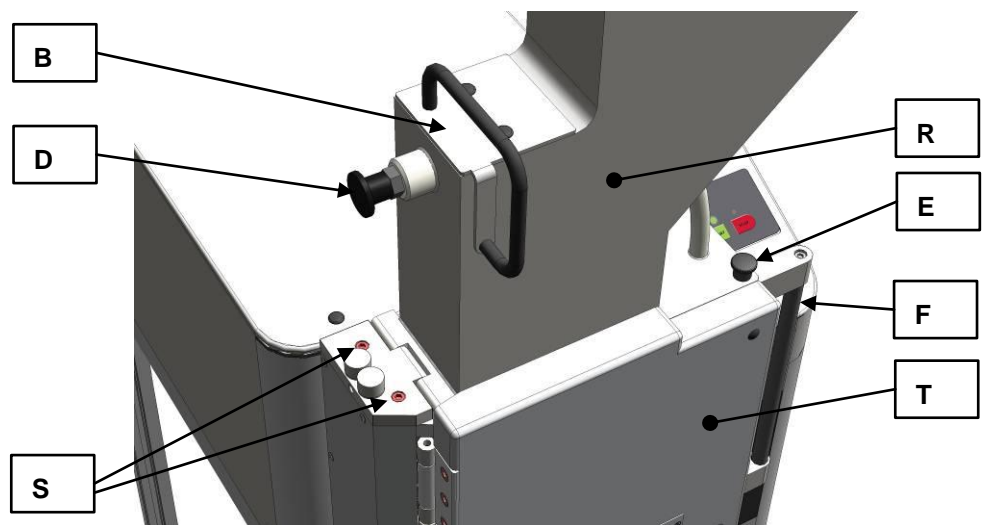

Fig. 4: Mounting the feed hopper

- Push the handle of the door latch (F) backwards.
- Open the grinding chamber door (T).
- Pull the plunger (B) into the upper latching position.
- Place the feed hopper (R) on the device. (see diagram)

 **CAUTION**

Until the feed hopper (R) is secured by two socket-head screws, there is a risk of it falling out of the device.

- Release the detent pin bolt (D) on the plunger (B).
- Push the plunger downwards.
- Screw the two provided socket-head screws (S) through the hinge on the feed hopper into the enclosure.
- At first, tighten the screws only slightly.
- Close the grinding chamber door.
- Pull the handle on the door latch (F) forwards until the mini detent pin (E) engages.
- Adjust the feed hopper until the plunger can be moved upwards and downwards easily without jamming.
- Tighten the two socket-head screws securely. (10 Nm)
- Check again if the plunger moves upwards and downwards easily without jamming.
- Put the two protective caps (SK) onto the screws (S).

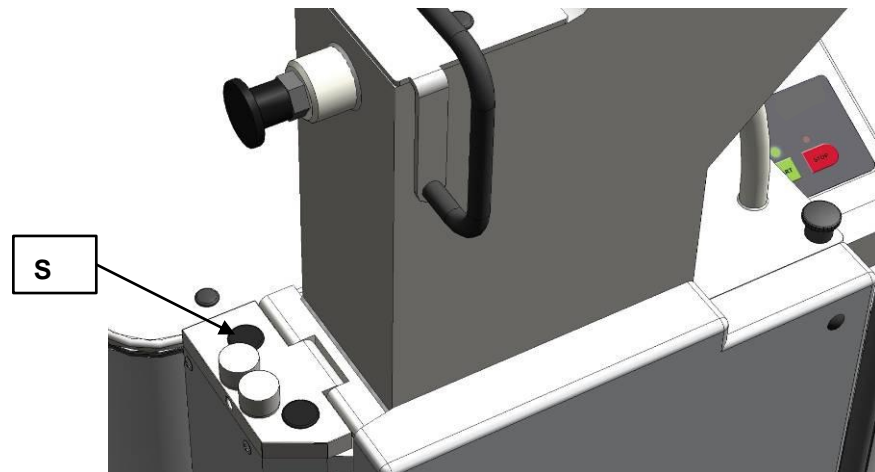

Fig. 5: Putting on the protective caps

NOTE

When new, the grinding chamber door and the handle on the door latch are somewhat difficult to move.

3.9 Installation of the machine

Installation height: maximum 2000 m above sea level

*NOTE***Installation**

- Depending on the operating status of the mill, there may be slight vibrations.
 - **Place the mill on an even, flat and balanced supporting surface only. The supporting surface must be stable and must not vibrate.**
-

*NOTICE***Installation of the machine**

- It must be possible to disconnect the machine from the mains at any time.
 - **Install the machine such that the connection for the mains cable is easily accessible.**
-

4 Technical data

4.1 Use of the machine for the intended purpose

Target group: Owners/managing operators, operators

Machine type designation: SM 200

This heavy-duty cutting mill serves to grind flexible, hard-ductile and fibrous products and product mixtures in batches or continuously. It is fundamentally not designed for grinding wet or moist materials. The special shape of the cutting tools in conjunction with the drive enables a fast, efficient grinding without adversely affecting the material to be ground.

Special features

The new heavy-duty cutting mill is convincing in difficult size reduction tasks where other cutting mills fail. The device allows a particularly effective preliminary size reduction of heterogeneous material mixes, such as waste or electronic components. Analytical fineness is usually attained in one step. The cutting mill is used successfully for a great variety of other materials also, whereby the sample material is only heated to a very low temperature and so the mill is also suitable for grinding temperature-sensitive materials.

The large selection of sieves, hoppers and collecting vessels allow adaptations to individual tasks.

- fast, gradual size reduction by 18 cutting plates arranged in a helical pattern along the circumference of the rotor
- parallel section rotor
- cutting tools made of high-quality materials
- high level of operating convenience due to central lock and operator panel
- consistent operational reliability in all user-relevant equipment components
- versatility in use due to a variety of devices and a large number of accessories
- powerful size reduction owing to a high-torque 2.2-KW motor
- optimised cutting effect by double-acting cutting bars
- very fast cleaning thanks to hinged enclosure with smooth surfaces and push-fit rotor
- defined final fineness due to bottom sieves with aperture sizes 0.25 - 20 mm

NOTICE

Area of use of the machine

- This machine is a laboratory machine designed for 8-hour single-shift operation.
- **This machine may not be used as a production machine nor is it intended for continuous operation.**

4.2 Emissions



Damage to hearing

The level of noise can be high depending on the type of material, the knife used, the speed set and the duration of the grinding process.

- Noise that is excessive in terms of level and duration can cause impaired or permanently damaged hearing.
- **Ensure suitable sound-proofing measures or wear hearing protection.**



Noise measurement in accordance with DIN 45635-31-01-KL3.

Immission at 1-m spacing:

- approx. 66 dB (A) at idle speed

During size reduction, depending on the sample material:

- approx. 75 to 92 dB (A) with peaks of up to 98 dB

4.3 Degree of protection

- IP54

4.4 Motor rotation speed

The rated speed of the motor is 1500 rpm.

4.5 Receptacle volume

The receptacle volume is < 5 l and is expandable by accessories to up to 26 l.

4.6 Rated power

– 2200 W

4.7 Dimensions and weight

In closed state: (with standard hopper)

Height: 1675mm

Width: 576mm (1090 mm with open hopper)

Depth: 760mm

Weight: approx. 120kg

Weight without rotor and without hopper: approx. 90kg

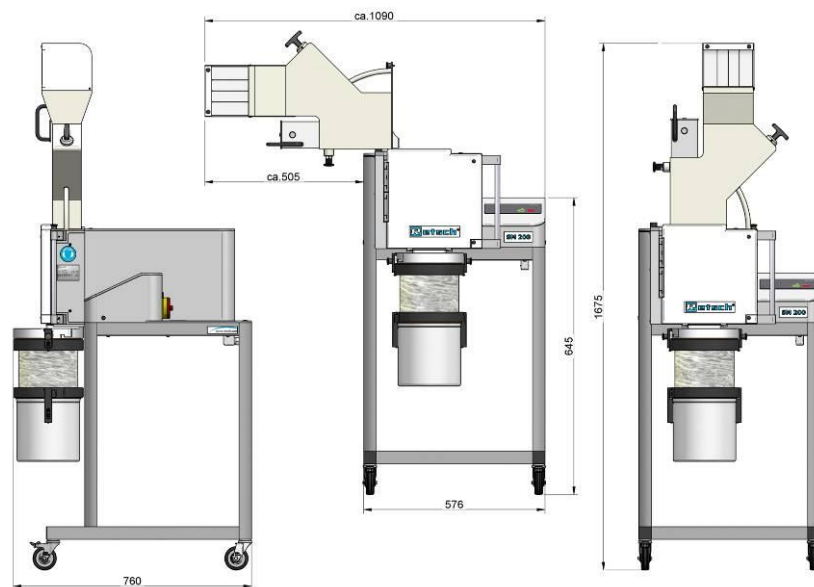

Fig. 6: Dimensions

4.8 Required floor space

1090 mm x 760 mm – no safety gaps necessary

5 Operating the machine

5.1 Views of the Instrument

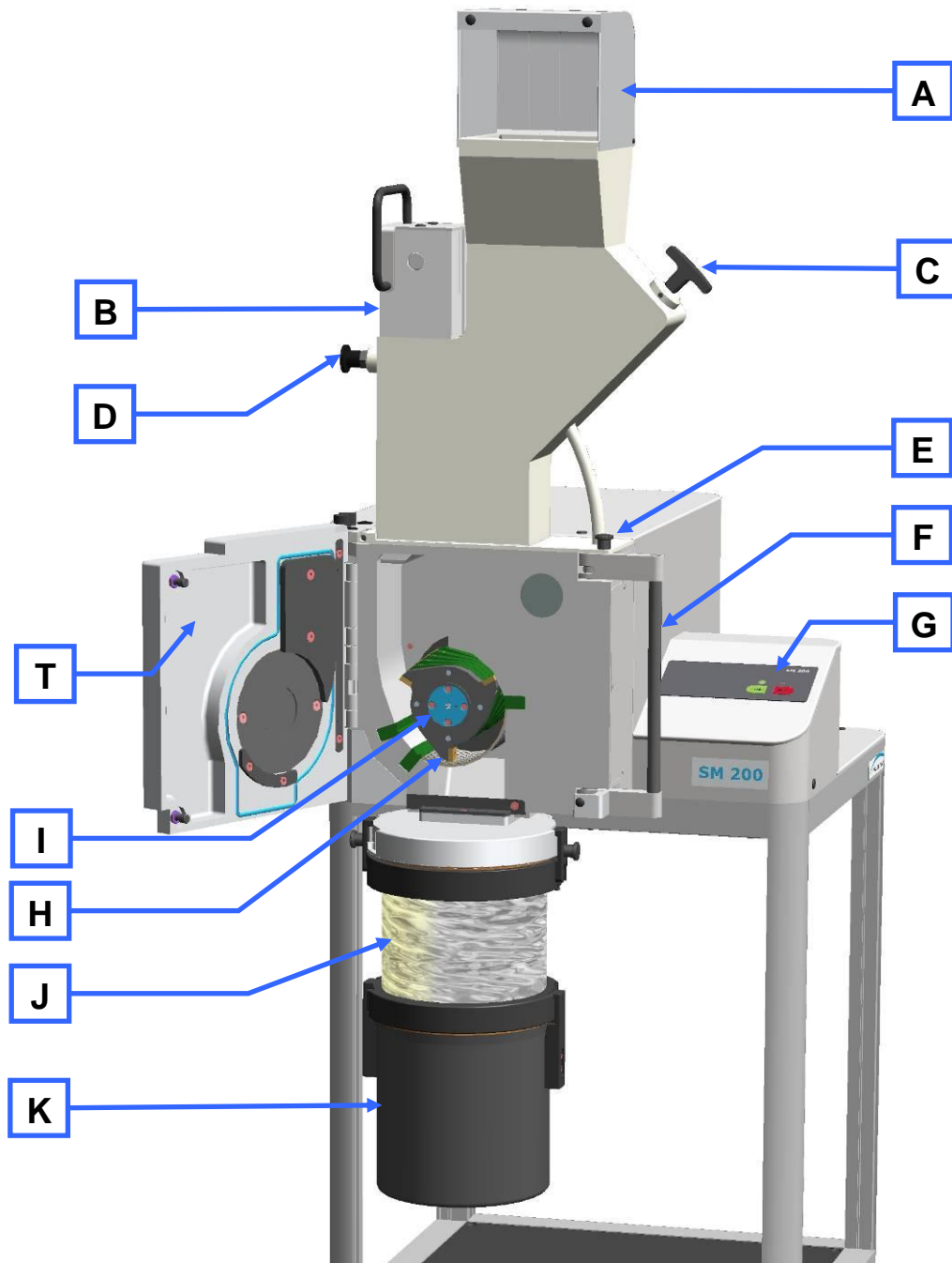

Fig. 7: Front view

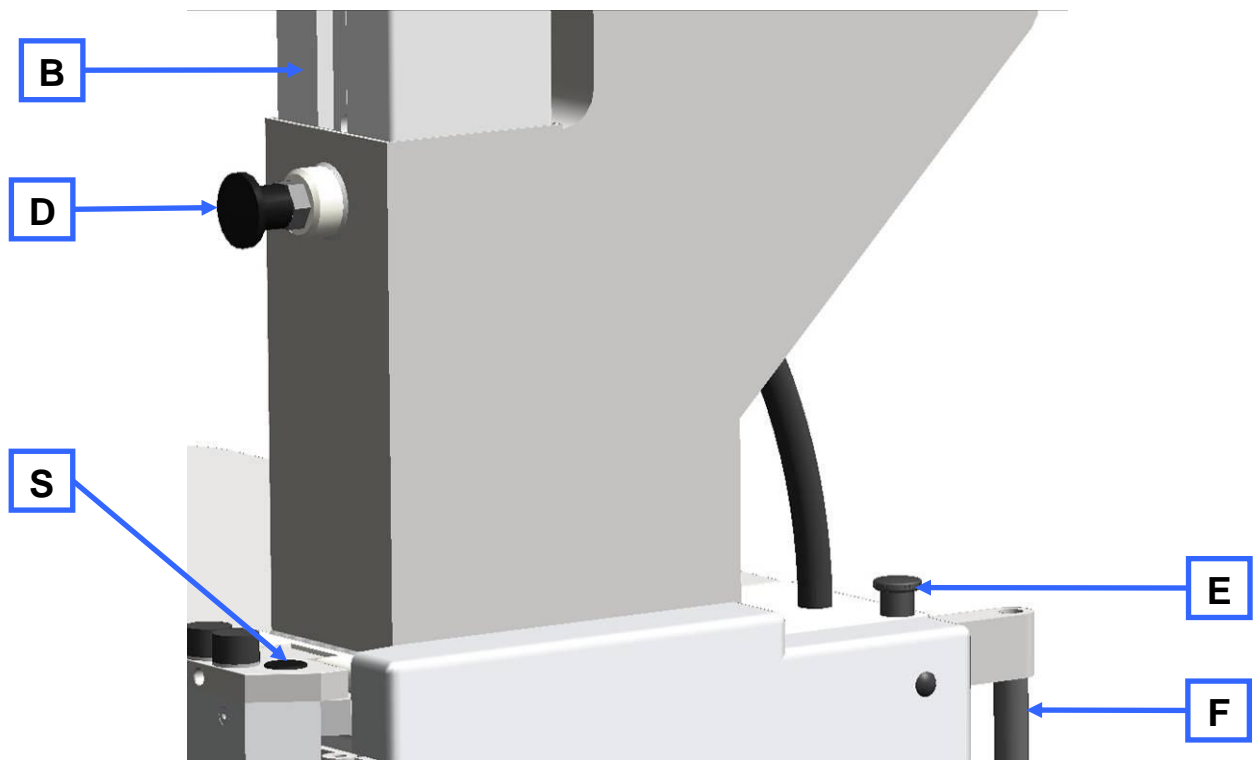

Fig. 8: Front view from the left (detail)

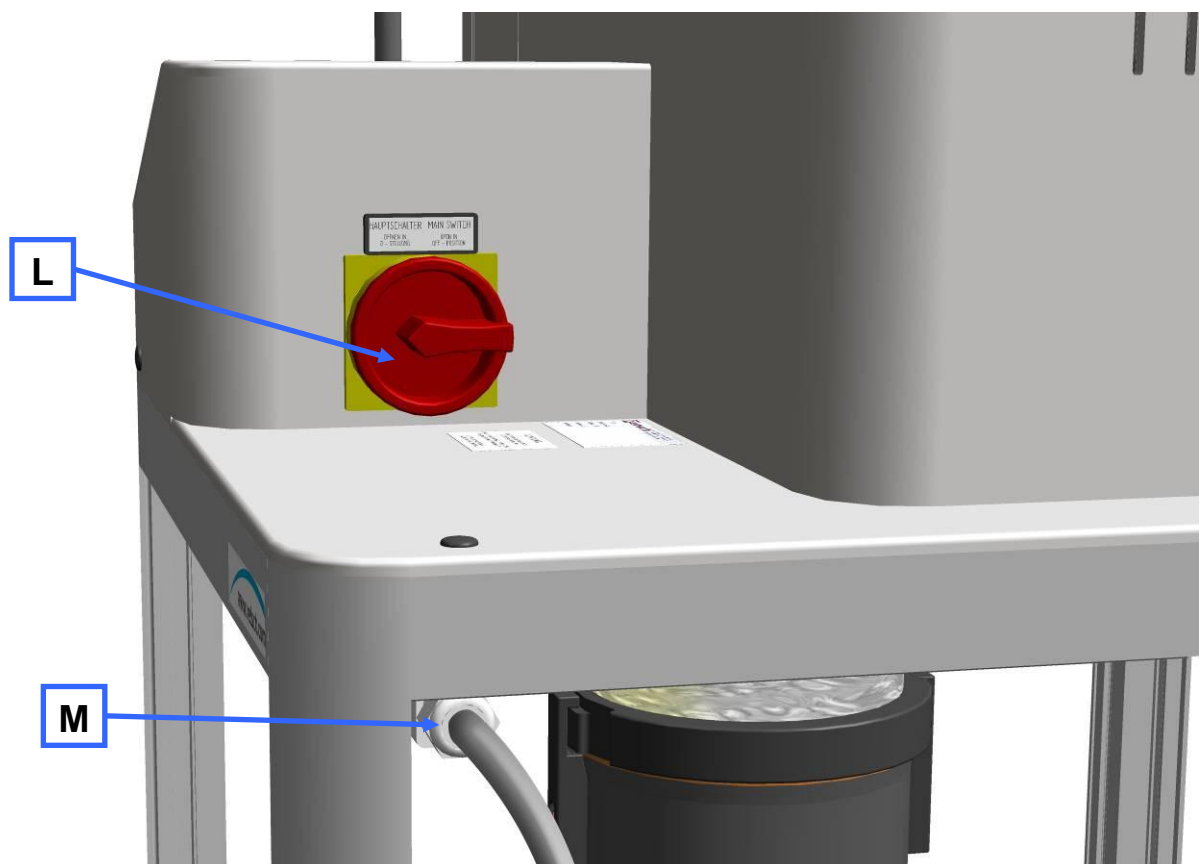

Fig. 9: Rear view

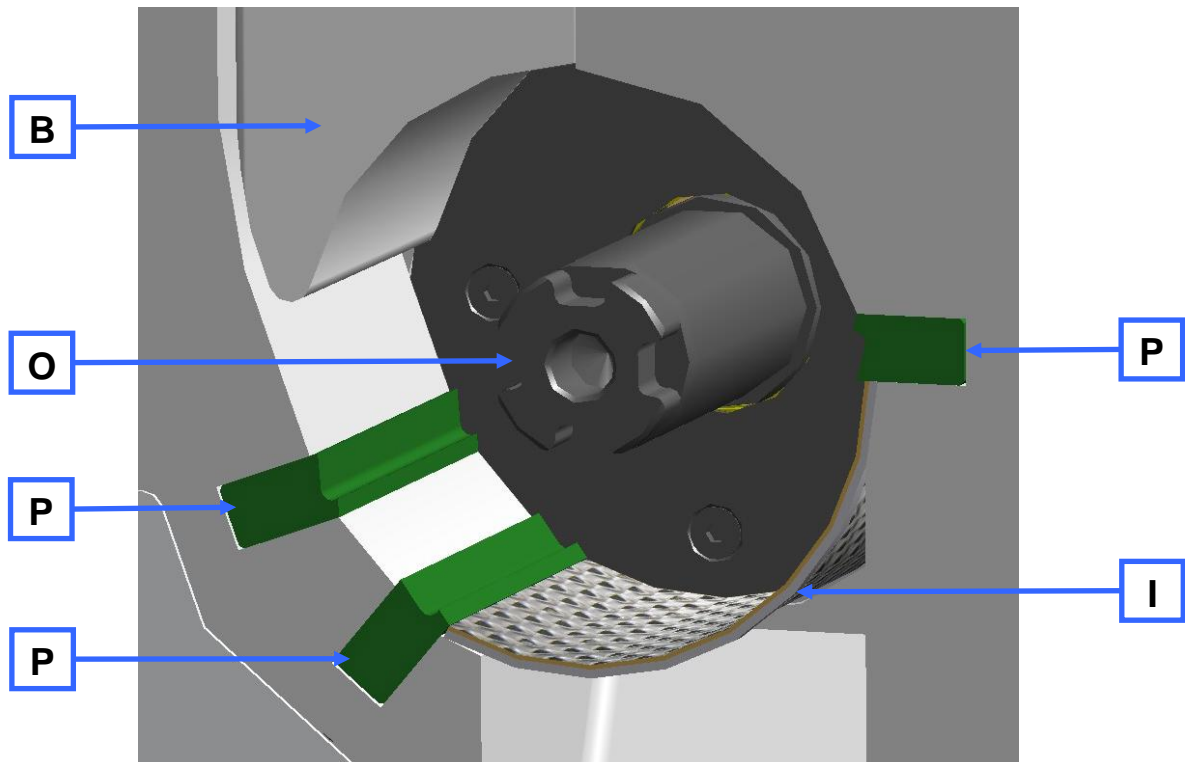

Fig. 10: View of the grinding chamber

5.2 Overview table of the parts of the device

Element	Description	Function
A	Feed hopper access barrier	Prevents people reaching into the feed hopper
B	Plunger	When pulled, it releases the material feed chute. Pushes sample onto the rotor.
C	Metering plunger	Pushes the material to be ground into the feed hopper area of the filling plunger <ul style="list-style-type: none"> – Pulled out: the material can be fed. – Pushed in: the material remains in the area of the filling plunger.
D	Detent pin	Prevents the filling plunger being pulled out, blocks it or releases it. <ul style="list-style-type: none"> – Pulled out: allows the filling plunger to move freely – Released: filling plunger latches in the top position
E	Mini detent pin	Locks the door latch
F	Handle for door latch	Allows the door to be opened
G	Control panel	Starting and stopping the device, setting the speed
H	Parallel section rotor	Size reduction tool
I	Bottom sieve	The size and type of its perforation influences the fineness of the material being comminuted
J	Ring filter	Air outlet and sieve for sample material
K	Collecting receptacle	Collects comminuted stock
L	ON/OFF switch (main switch)	Connecting and disconnecting the device to/from the power grid. <ul style="list-style-type: none"> - ON = LED (red) STOP lights up - OFF = all LEDs are off
M	Connection cable	Power connection
O	Rotor shaft	Accommodates the size reduction tool
P	Cutting bars	Counterpart for the size reduction tool
R	Feed hopper	For feeding the sample material
S	Fastening screws for feed hopper	Locking screws for the feed hopper
T	Grinding chamber door	Closes the grinding chamber

5.3 Operating elements and displays

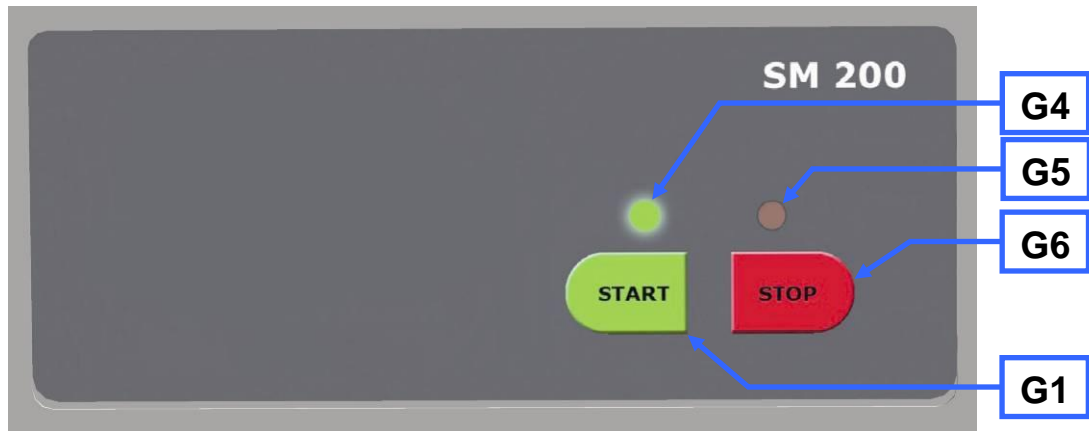

Fig. 11: View of the control panel and the display

5.4 Overview Table of the Operating Elements and the Display

Element	Description	Function
G1	Start button	Starts the device
G6	Stop button	Stops the device
G4	Green LED	Device is on
G5	Red LED	Device ready for use/flashing light indicates an error

5.5 Opening and closing of the grinding chamber

The motor must come to a complete stop before the mill housing can be opened.

- Stop the device by pressing the stop button (G6).
- Pull the mini detent pin (E) upwards
- Press the handle on the door latch (F) backwards.
- Open the grinding chamber door.

NOTE

Do not close the grinding chamber door if the feed hopper is folded out to the side, because this would damage the device.

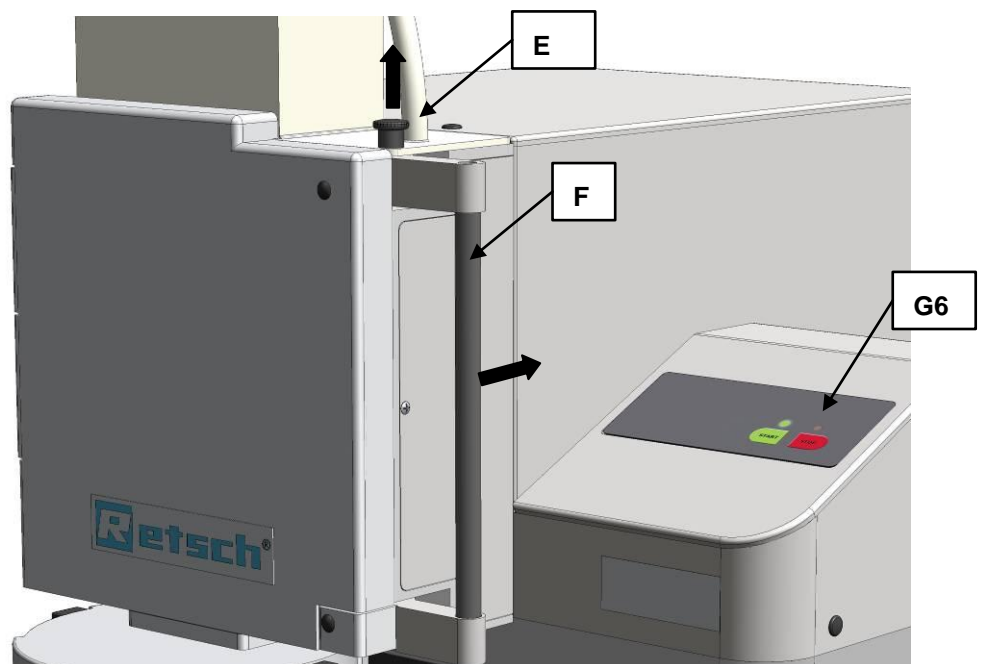

Fig. 12: Opening the grinding chamber door

5.6 Mounting the bottom sieve

- Select the appropriate bottom sieve.
- Open the mill housing and push the bottom sieve (I) of your choice into the device.

5.7 Replacing the rotor

CAUTION

Injuries in the form of cuts

Sharp cutting edges on the rotors and cutting bars

- The sharp cutting edges on the rotors and cutting bars can injure hands.
- **Wear protective gloves when replacing the cutting rotors and cleaning the grinding chamber.**
- **Use the rotor extraction tool when handling the cutting rotors.**

NOTE

Reduction of tool service life

Abrasive sample materials

- The presence of abrasive composite materials during grinding can considerably reduce tool service life.
- **When grinding electronic scrap, take the properties of the composite materials into account.**

NOTE

Damage to mechanical components

Blockages typical of cutting mills

- When coarse, solid material is fed in for grinding, the high feeding capacity of the standard rotor can cause blockages that are typical of the cutting mills.
- **If blockages occur, switch off the mill immediately and remove the clogging material.**

5.7.1 Removing the Rotor

- Stop the device.
- Open the grinding chamber door.
- Screw the extraction tool (EG) onto the rotor and pull the rotor off the driving shaft.

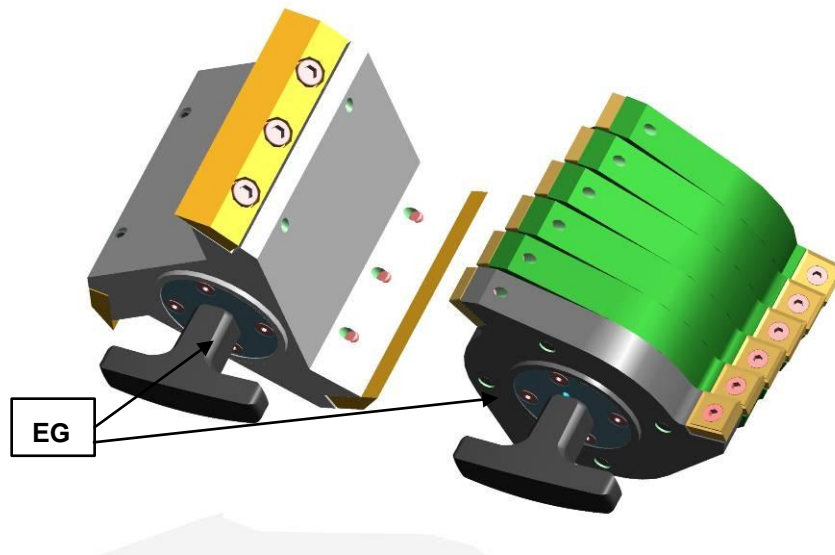

Fig. 13: Extraction tool

5.7.2 Inserting the Rotor

- Clean and lubricate the motor shaft as well as the rotor.
- Push the rotor onto the motor shaft.

The device is otherwise essentially maintenance-free.

However, we recommend a regular inspection of the cutting tools depending on the frequency of use but at least once a month.

5.8 Inserting the filter unit and collecting receptacle

The filter unit serves as an air outlet for the air flow generated by the comminuting rotors.

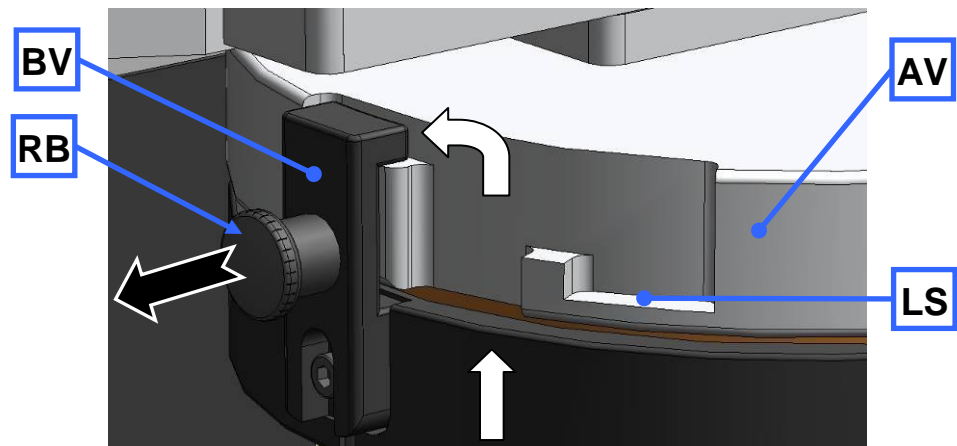

Fig. 14: Mounting and removing the filter unit

- As shown in the illustration, insert the bayonet fixing(BV) that is on the filter unit (J) into the discharge flange(AV).
- Turn the filter unit in a clockwise direction in order to engage the bayonet fixing.
- To remove the filter unit, pull the detent pin (RB) to release the bayonet fixing (BV).

Alternatively, the collecting receptacle can be put onto the discharge flange directly. In the latching position (BV) the air flow is prevented from escaping.

In the latching position (LS) a gap remains between the discharge flange and the collecting receptacle remains and this allows air to flow out .

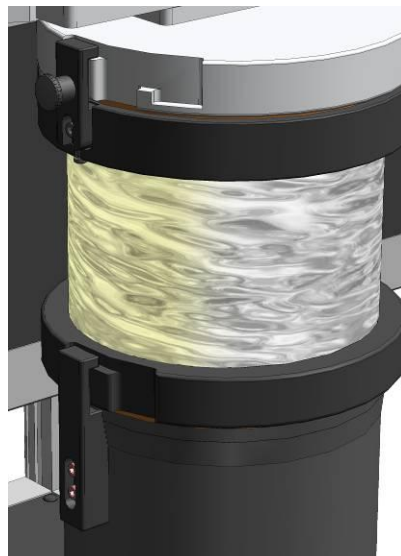

Fig. 15: Collecting receptacle and filter unit

5.9 Starting the grinding process

Switch on the power switches on the back of the device.

Press the START button.

NOTE

Make sure the device is running before you fill in the sample material. Otherwise, motor blockages can occur as the device is starting up.

5.10 Stopping the grinding process

The grinding process can be interrupted by pressing the stop button (G6).

Once the motor has stopped, you can pull the mini detent pin (E) upwards and press the handle on the door latch (F) backwards.

The grinding chamber door can be opened now.

6 Mode of Operation of Feed Hopper

NOTE

Motor blockage

The material being ground clogs the rotor

- Blockages can damage mechanical components.
 - **Feed material only while the device is running.**
 - **Dose the material feed to suit the properties of the material.**
-

- Turn on the device.
- Pull the metering plunger (C) and the plunger (B) upwards.
- Put the material to be ground into the filling hole(AE).
- If necessary, use the metering plunger to push the material to be ground in further.
- Seize the plunger by the grip and pull the detent pin (D).
- Press the plunger downwards slowly.

NOTE

Do not use excessive force on the plunger. **Blockages can damage mechanical components.**

In most cases, the plunger's own weight is sufficient to press the material to be ground into the grinding chamber.

If not, press the plunger to push the material in further, gently and in accordance with the device's capacity.

7 Assembling and using the cyclone

7.1 Cyclone assembly

 **CAUTION**

2.V0014

Injuries to limbs
Rotating blade

- Can cause injury to hands and feet.
- **Keep hands and feet away from the device openings when the device is switched on.**
- **Pull the plug out before cleaning or retrofitting.**



 **CAUTION**

3.V0001

Risk of injury to fingers
Reaching into the turning rotor

- Unintended reaching into the grinding area and the turning rotor.
- **Never connect the device to the mains without the discharge flange.**
- **Only operate the device with discharge flange.**

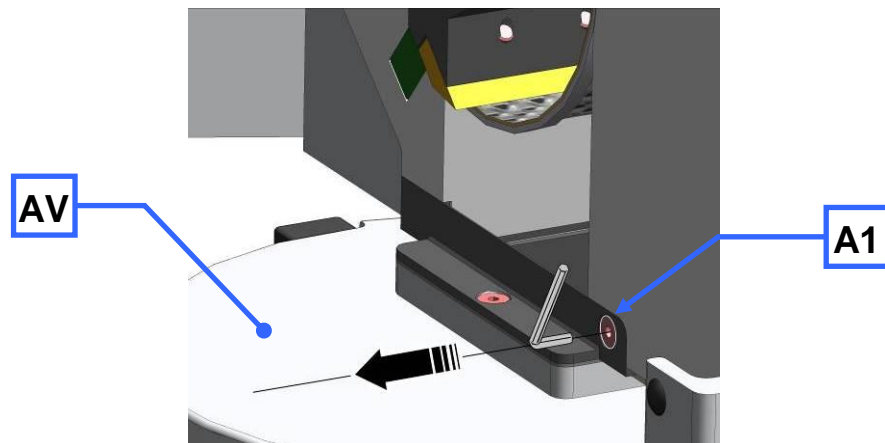

Fig. 16: Removing the discharge flange

- Disconnect the device from the mains.
- Loosen the screw (A1).
- Pull off the discharge flange (AV).

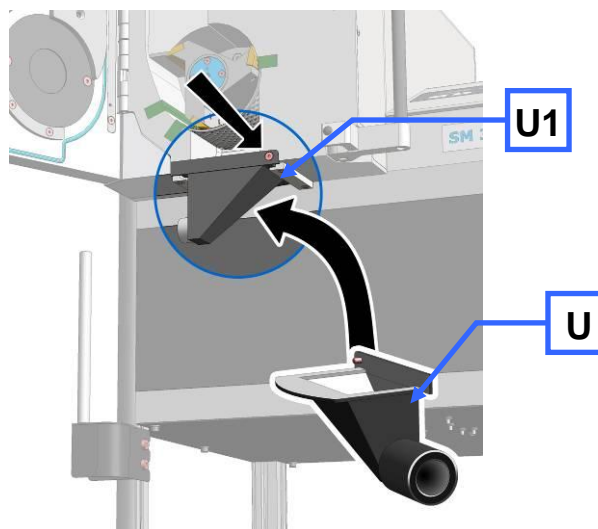

Fig. 17: Fastening the discharge flange

- Insert the retrofit dust removal (**U**).
- Tighten the screw (**U1**).

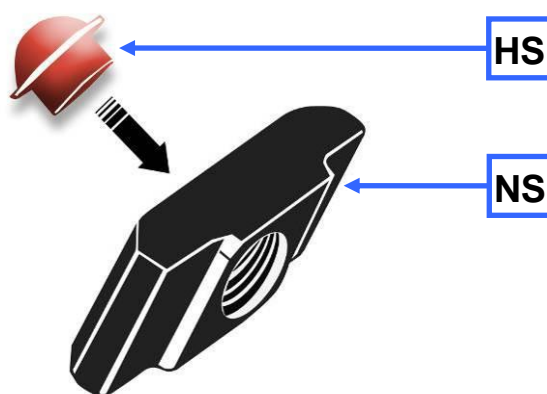

Fig. 18: Inserting the plug for the sliding block

- Insert the plug (**HS**) into the back (flat surface) of the sliding block (**NS**).

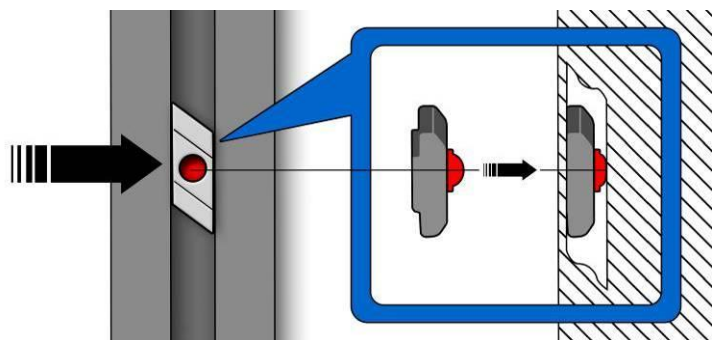

Fig. 19: Inserting the sliding block

- Guide the sliding block with plug into the aluminium profile.

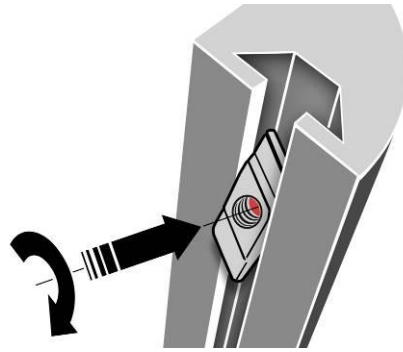

Fig. 20: Turning the sliding block

- Push in the sliding block against the resistance of the plug and turn the sliding block to the position indicated.
- Insert the second sliding block in the same way.

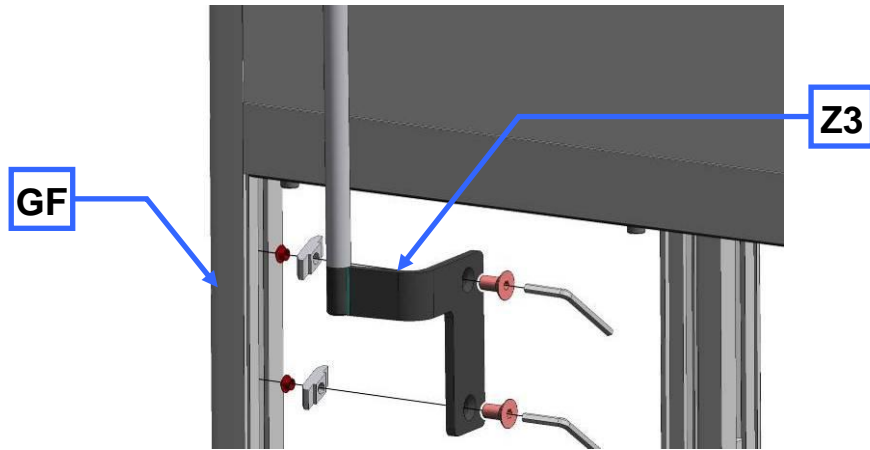

Fig. 21: Fastening the cyclone support

- Fasten the cyclone support (**Z3**) on the front left-hand leg of the housing (**GF**).

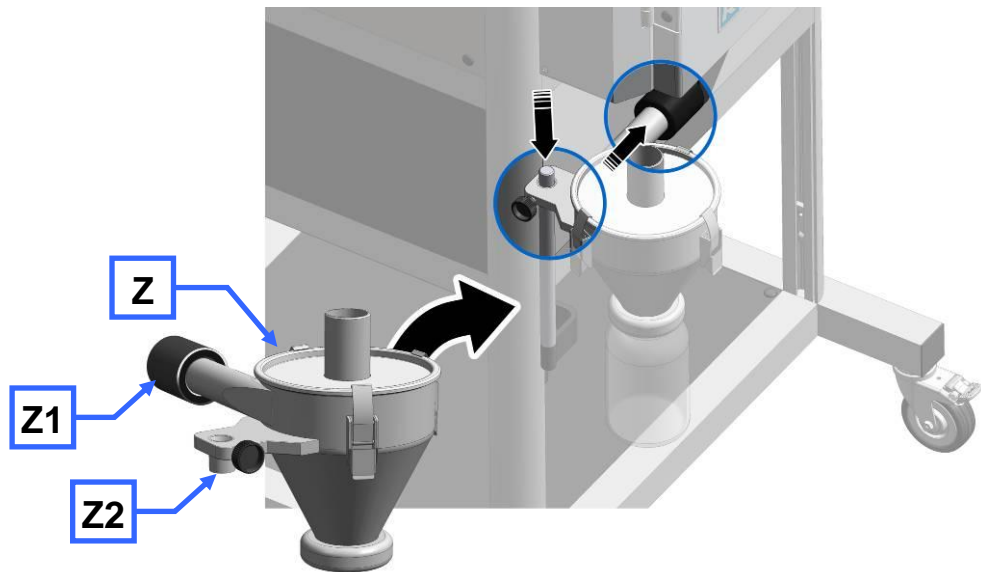

Fig. 22: Installing the cyclone

- Connect the cyclone (**Z2**) onto the rod of the stand on the cyclone support.

- Turn the side tube to the discharge flange and push the coupling (Z1) onto the adapters on the discharge flange.

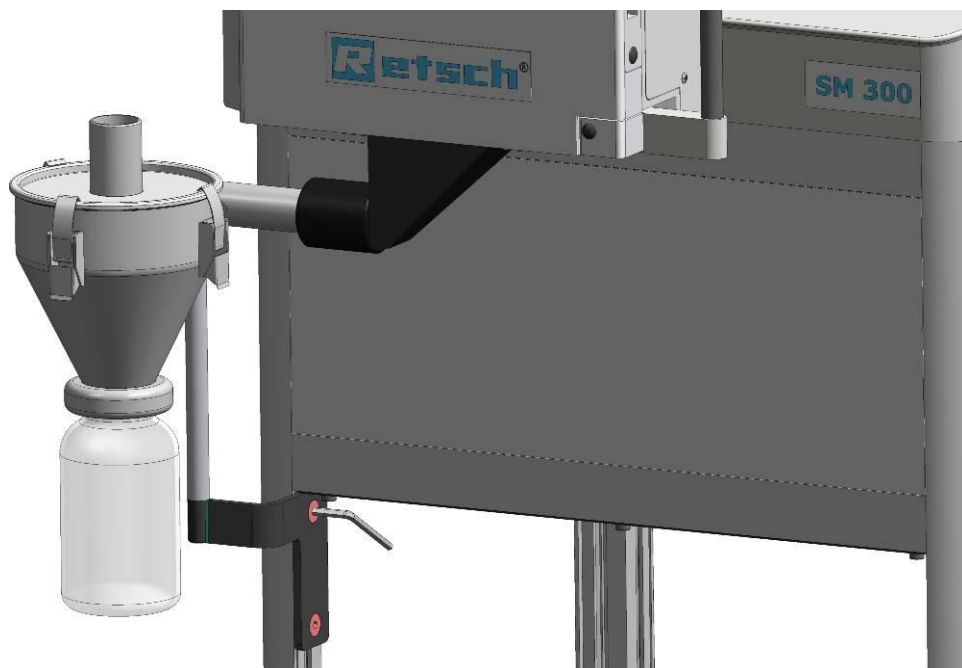

Fig. 23: Assembled cyclone

 **CAUTION**

Before using the industrial vacuum cleaning, read the operating instructions supplied with the vacuum cleaner.

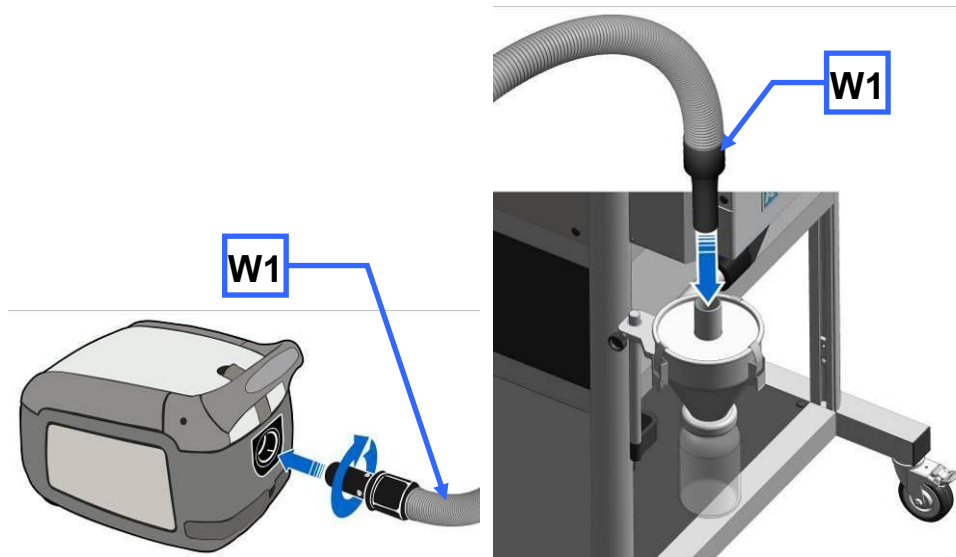

Fig. 24: Connecting the industrial vacuum cleaner

- Plug the connector for dust extraction (W1) into the top opening on the cyclone.

7.1.1 Inserting the wide mouth bottle adapter

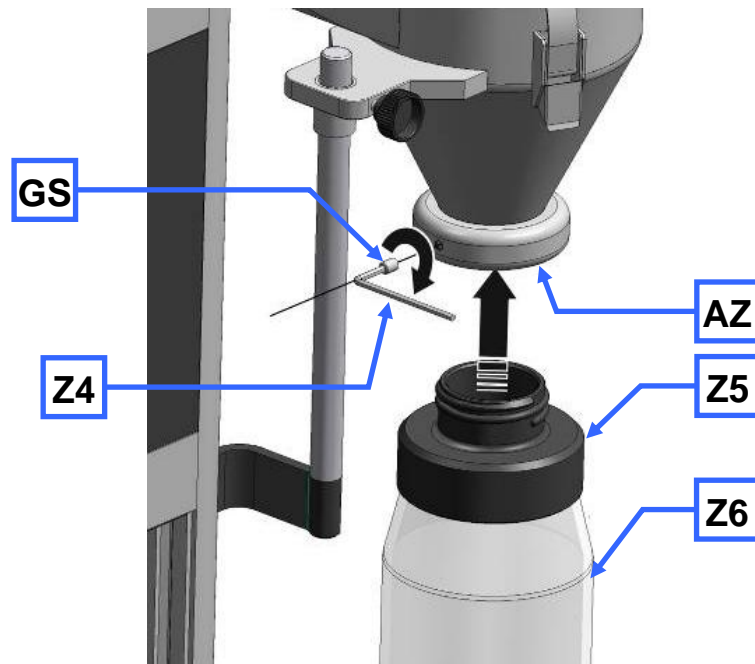

Fig. 25: Inserting the wide mouth bottle adapter

- Insert the adapter for wide mouth bottles (Z5) into the outlet opening of the cyclone (AZ) .
- Affix the adapter using the threaded pin (GS).
- Use a SW3 Allen key to screw in the threaded pin (Z4).

This avoids the adapter turning when the wide mouth bottles are screwed in and out.

You can use 1l, 2l and 5l wide mouth bottles.

8 Cleaning and service

8.1 Adjusting the cutting bars

To ensure that the device will function satisfactorily, it is necessary to check the cutting gap (target spacing 0.3 mm). The (SL) cutting bars are therefore moveable so that the cutting gap can be set.

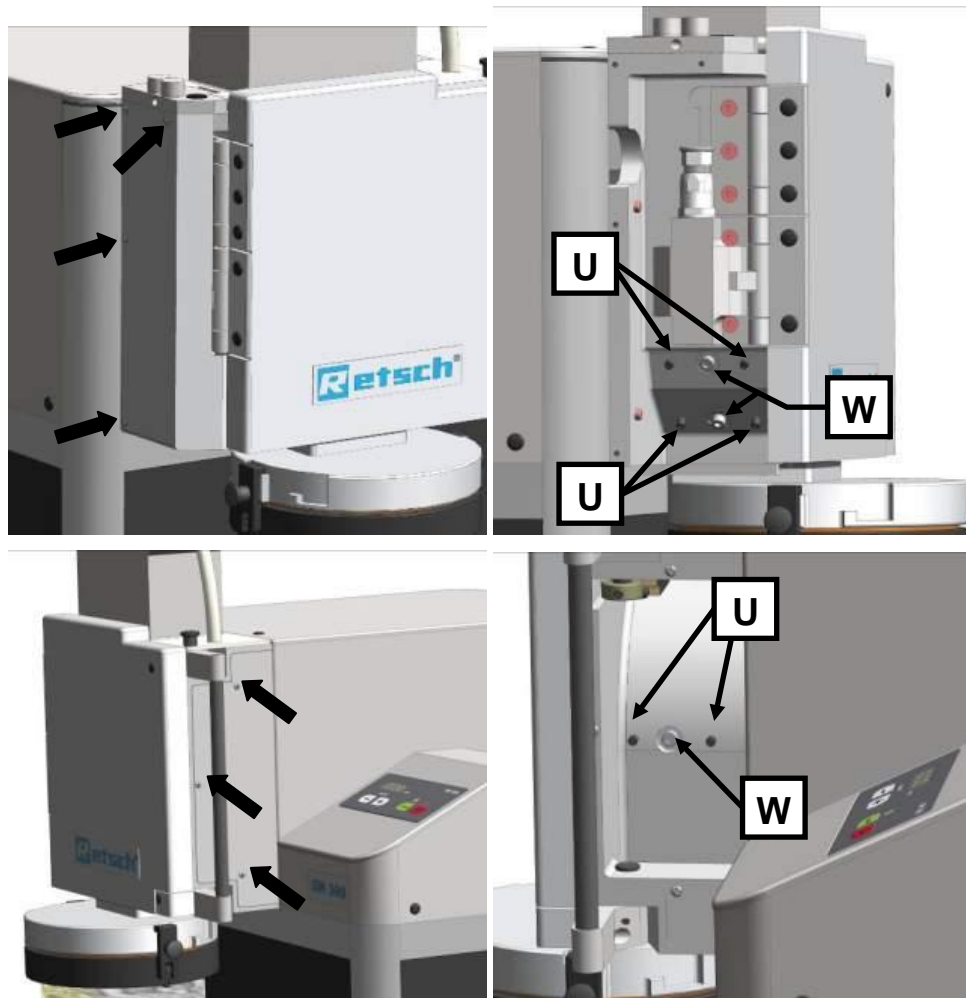

Fig. 26: Access to the cutting bars

- Loosen the four screws in the left cover.
- Loosen the three screws in the right cover.
- Open the grinding chamber door.
- Pull the rotor approx. 10 mm out of the grinding chamber until it can move freely.

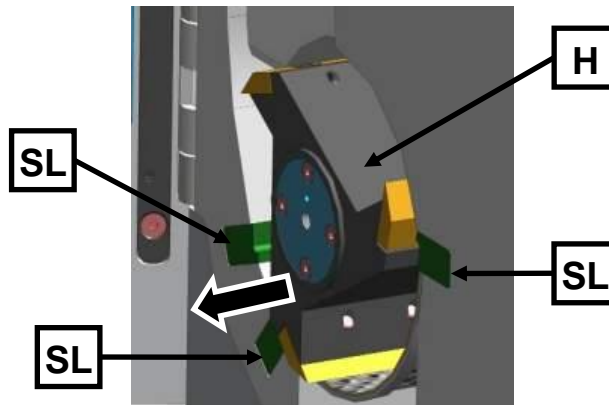

Fig. 27: Twist the rotor until it rotates freely

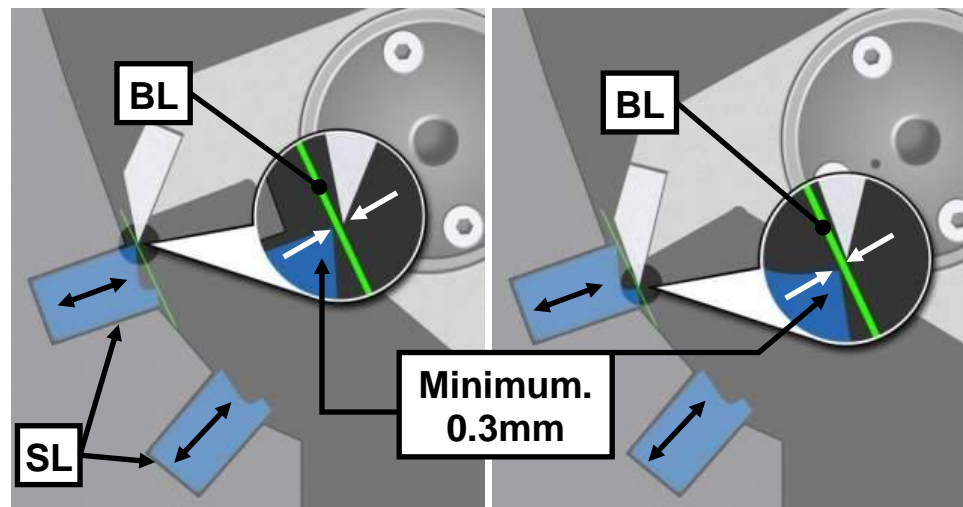

Fig. 28: Setting the cutting gaps

- Use a (BL) feeler gauge to check the cutting gap between all three (SL) cutting bars. The gap should be at least 0.3 mm.

The (BL) feeler gauge must be put on the two cutting surfaces as shown in the illustration. The cutting gap must have the same spacing along its entire depth. Check the cutting gap along its entire depth therefore.

The cutting edge with the smallest spacing from the knife marks the cutting gap (SP1/2). The second cutting edge can have a larger cutting gap.

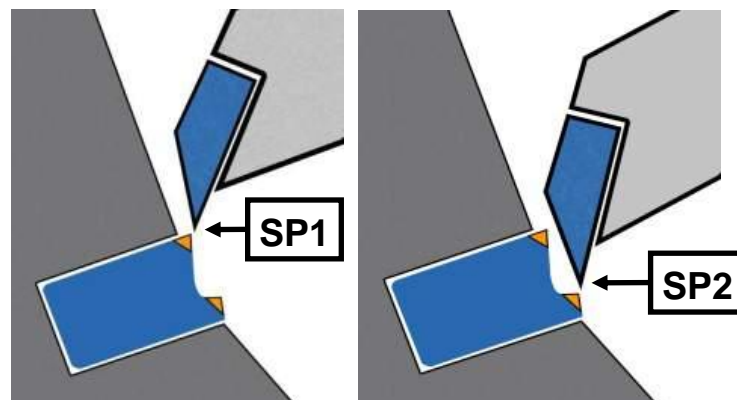

Fig. 29: Cutting gap





- Turning the studs (**U**) in a clockwise direction pushes the cutting bar closer to the rotor knife and reduces the cutting gap accordingly. Turning in an anti-clockwise direction increases the cutting gap.
- Tighten the (**WS**) screw and check the cutting gap. Repeat the procedure if necessary.
- Tighten the (**W**) screw at 7Nm again after adjusting the cutting bar.
- Then mount the right and left covers onto the device again.

NOTE

Do not set the cutting gap at less than 0.3 mm. Contact between the cutting plates and the cutting bars can damage mechanical components.

The tightening torque for the (**W**) screw must be 7Nm. It is not otherwise possible to guarantee that the cutting bars will be positioned securely.

9 Fault messages

Flashing sequence	Meaning	Instruction
G4 and G5 flash alternately 	Safety circuit is not closed	<ul style="list-style-type: none"> • Close the door. • Pull the locking bracket forwards. • Allow the locking bolt to engage.
G5 flashes 	Motor block	<ul style="list-style-type: none"> • Remove the blocking pieces of sample material from the grinding chamber. • Press button G6 • Press button G1.
G4 + G5 flash simultaneously 	Faulty relay contact	<ul style="list-style-type: none"> • Service necessary!
G4 flashes 	Revolving field detection	<ul style="list-style-type: none"> • Switch the two phases (L1 with L2) on the power cable

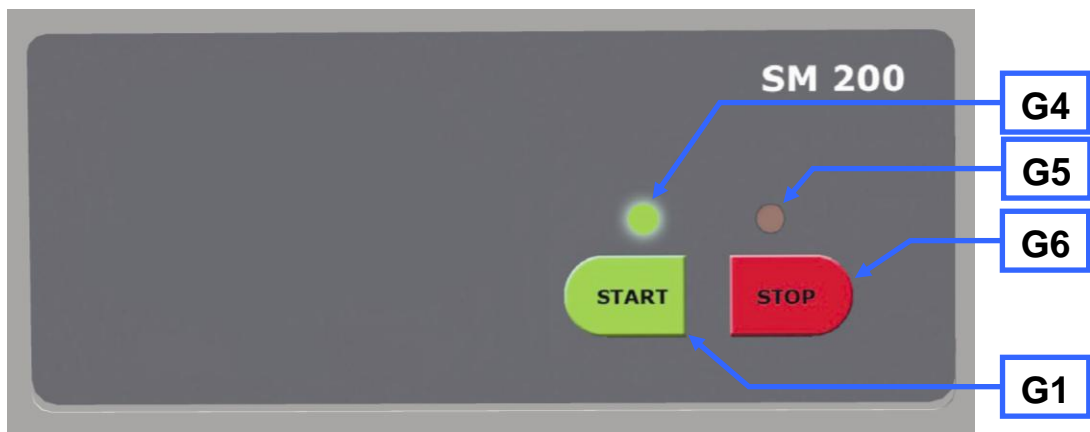

Fig. 30:Flashing sequence during error message

10 Disposal

Please observe the respective statutory requirements with respect to disposal.

Information on disposal of electrical and electronic machines in the European Community.

Within the European Community the disposal of electrically operated devices is regulated by national provisions that are based on the EU Directive 2002/96/EC on Waste Electrical and Electronic Equipment (WEEE).

Accordingly, all machines supplied after 13.08.2005 in the business-to-business area to which this product is classified, may no longer be disposed of with municipal or household waste. To document this they have the following label:

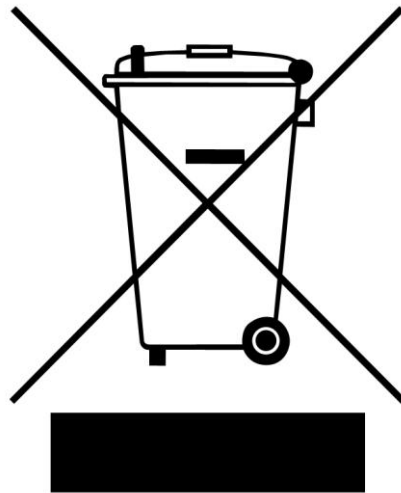

Fig. 31: Disposal label

Since the disposal regulations within the EU may differ from country to country we would request you to consult your supplier.

11 Index

2

2200 W 18

A

Access to the cutting bars 34

Adjusting the cutting bars 34

Air flow 26

Air outlet 26

Amperage 12

Assembling and using the cyclone 29

Atmospheric humidity 10

B

Bar code 12

Bayonet fixing 26

C

Capacity 12

CE marking 12

Changes 5

Cleaning and service 34

Collecting receptacle and filter unit 26

Conditions for the place of installation 10

Confirmation 9

Connecting the industrial vacuum cleaner 32

Connection cable 11

Copyright 5

Cutting gap 35

Cyclone assembly 29

D

Degree of protection 17

Description 22, 23

Device designation 11

Dimensions and weight 18

Discharge flange 26

Disposal 38

Disposal label 12

Disposal label 38

E

Electrical connection 11

Emissions 17

Error message 37

Explanations of the safety warnings 6

External fuse 11

Extraction tool 25

Eye bolt 12

F

Fastening the cyclone support 31

Fastening the discharge flange 30

Fault messages 37

Filling hole 28

flash 37

flashing 37

Flashing sequence 37

Flashing sequence during error message 37

Frequency of use 25

Front view 20

Front view from the left (detail) 20

Function 22, 23

Fuse strength 12

Fuse type 12

G

General safety instructions 7

I

Inserting the filter unit and collecting receptacle 26

Inserting the Rotor 25

Inserting the sliding block 30

Inserting the wide mouth bottle adapter 33

Inspection 25

Installation height 14

Installation of the machine 14

Installing the cyclone 31

IP54 17

L		
lubricate	25	
M		
Mains frequency	12	
maintenance-free.....	25	
Manufacturer's address	11	
Maximum relative humidity	10	
Mode of Operation of Feed Hopper.....	28	
Moderate or mild injury	6	
monthly	25	
Motor rotation speed.....	18	
Motor shaft.....	25	
Mounting and removing the filter unit	26	
Mounting the bottom sieve.....	24	
Mounting the feed hopper.....	13	
Mounting the Feed Hopper.....	12, 13	
N		
Noise measurement.....	17	
Notes on the Operating Manual.....	5	
Number of fuses	12	
O		
Opening and closing of the grinding chamber....	24	
Opening the grinding chamber	24	
Operating elements and displays	23	
Operating the machine	19	
Overview Table of the Operating Elements and the Display	23	
Overview table of the parts of the device	22	
P		
Packaging	10	
Part number	11	
Plug.....	30	
Power version	12	
property damage.....	6	
Putting on the protective caps	14	
R		
Rated power	18	
Rated speed of the motor	18	
Rear view	20	
receptacle volume.....	18	
Receptacle volume	18	
Regulations for the place of installation	11	
Removing the discharge flange	29	
Removing the Rotor	25	
Removing the transport aid.....	12, 13	
Removing the Transport Safeguard.....	13	
Removing Transport Safeguards.....	12	
Repairs.....	8	
Replacing the rotor.....	24	
Required floor space.....	18	
S		
Safety warnings	6	
Serial number.....	11	
serious injury.....	6	
Service Address.....	8	
Setting the cutting gaps	35	
Sliding block.....	30	
Starting the grinding process	26	
Stopping the grinding process	27	
T		
Target group	7	
Technical data.....	16	
Temperature fluctuation and condensed water .	10	
Transport.....	10	
Transport, scope of delivery, installation	10	
Turning the sliding block	31	
Twist the rotor until it rotates freely	35	
Type plate	11	
type plate description.....	11	
Type plate lettering	11	
U		
Use of the machine for the intended purpose....	16	
V		
View of the control panel and the display	23	
Views of the Instrument	19	

Y

Year of production..... 11

LABORATORY CUTTING MILL SM200

Certificate of CE-Conformity according to:

EC Mechanical Engineering Directive 2006/42/EC

Applied harmonized standards, in particular:
DIN EN ISO 12100 Security of machines

EC Directive Electromagnetic Compatibility 2004/108/EC

Applied standards, in particular:
DIN EN 55011 B / Generic standard interference emission - living areas -
DIN EN 61326-1 Immunity

Additional applied standards, in particular

DIN EN 61010 Safety prescriptions concerning measuring-, operating-, controlling- and
laboratory equipment

Authorized person for the compilation of technical documents:

J. Bunke (technical documentation)

The following records are held by Retsch GmbH in the form of Technical Documentation:

Detailed records of engineering development, construction plans, study (analysis) of the measures required for conformity assurance, analysis of the residual risks involved and operating instructions in due form according to the approved regulations for preparation of user information data.

The CE-conformity of the Retsch laboratory cutting mill SM200 is assured herewith.

In case of a modification to the machine not previously agreed with us as well as the use of not licensed spare parts and accessories this certificate will lose its validity.

Retsch GmbH

Haan, October 2010

Ralf Eisenbach Dipl.-Ing.





Copyright

® Copyright by
Retsch GmbH
Haan, Retsch-Allee 1-5
D-42781 Haan
Federal Republic of Germany